

Keysight Technologies

Active Differential Probes

U1818A 100 kHz to 7 GHz
U1818B 100 kHz to 12 GHz

Technical Overview



Mess- und Prüftechnik. Die Experten.

Ihr Ansprechpartner /
Your Partner:

dataTec AG
E-Mail: info@datatec.eu
>>> www.datatec.eu



KEYSIGHT
TECHNOLOGIES

Premium Plus Distribution Partner



Introduction

The Keysight Technologies, Inc. U1818A/B active differential probes provide high differential input impedance from 100 kHz to 7 or 12 GHz. Suitable for those in R&D and quality assurance who are performing RF/Microwave and high-speed digital design and validation work in wireline, wireless communications and aerospace and defense industries. Designed to be directly compatible with Keysight's network, spectrum and signal source analyzers, these probes enable you to quickly find and fix defects while taking full advantage of the instruments capability.

The U1818A/B active differential probes are available with a variety of probe heads for different application needs. They can also be used with most of Keysight's probe accessories including extreme temperature extension cable, in-line attenuator kit, minimum loss attenuator pad, DC blocking capacitors, probe positioners and others to achieve accurate measurements.

Key Features and Benefits:

- Broad bandwidth with flat frequency, +/- 1.5 dB, which ensures excellent measurement accuracy and helps users achieve the best product specifications.
- Low noise floor, less than -130 dBm/Hz at 10 MHz to 12 GHz, which allows measurements to be made at a low signal amplitude.
- Convenience biasing from Keysight's RF and microwave instruments probe power port or bench top power supply for user flexibility.

Using a Network Analyzer with Active Differential Probes

Below is an application showing the U1818A/B with a network analyzer measuring step response in a high-speed digital design. In this application, the network analyzer provides the signal at one end while the active differential probe is used to measure the insertion loss between the DUT at the other end. The network analyzer will automatically transform the output signal from frequency domain to time domain for the frequency sweep selected. After the conversion of the signal, you will be able to identify the rise time, fall time or overshoot values which is essential in verifying the PCB design. The in-circuit measurement method of using the active differential probe with a network analyzer will provide accurate measurements with bigger dynamic range.

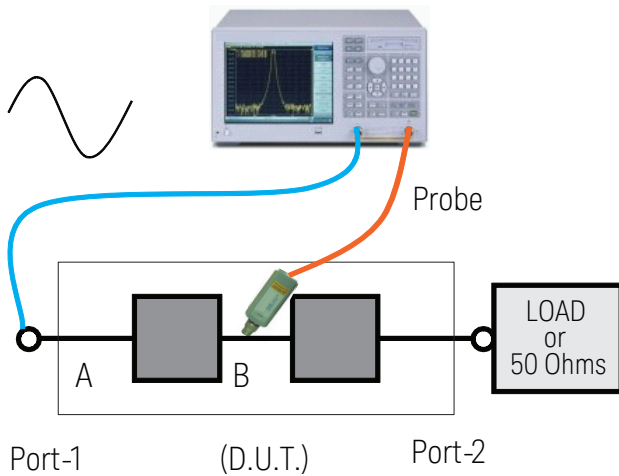

Figure 1. Test setup for step response measurement with Keysight network analyzer

Using a Signal/Spectrum Analyzer with Active Differential Probes

In this application, the active differential probe is used with a Keysight signal/spectrum analyzer for RF troubleshooting. As shown in the diagram below, the active probe is connected to the spectrum analyzer and the signal source is provided by the DUT itself. The method begins by probing the component at each stage one at a time and the values are measured in terms of power or harmonics. Users will be able to identify the problem area through the measurement reading on the spectrum analyzer.

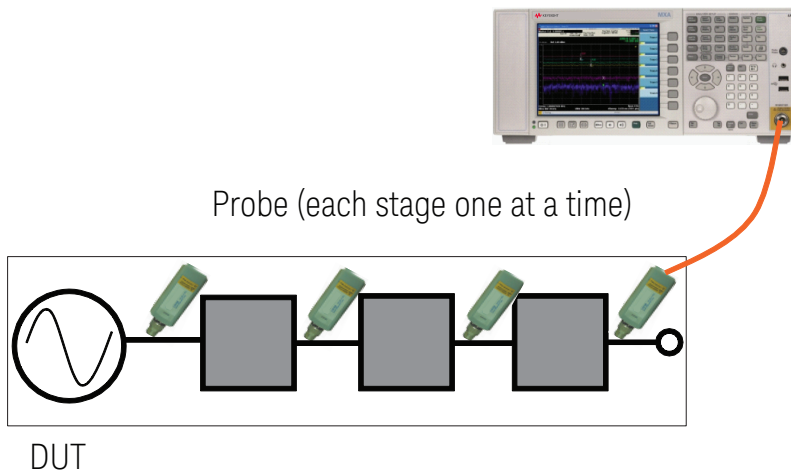

Figure 2. Test setup for general RF troubleshooting with spectrum analyzer

Using signal source analyzers with active differential probes

Other important parameters are phase noise and/or jitter when designing a high-speed digital PCB. The phase noise and jitter value can be accurately measured with the active differential probe and a signal source analyzer. Similar with the application shown in the diagram above, the signal source is provided by the DUT itself and the probe is used to measure the value at each stage at one time. The spectrum analyzer will show the value of the phase noise and jitter stage by stage. The difference between the parameters will easily enable you to identify the problem area during the design of the PCB. This application provides an accurate measurement with a broad dynamic range where jitter and phase noise can be measured down to a few femto-seconds.

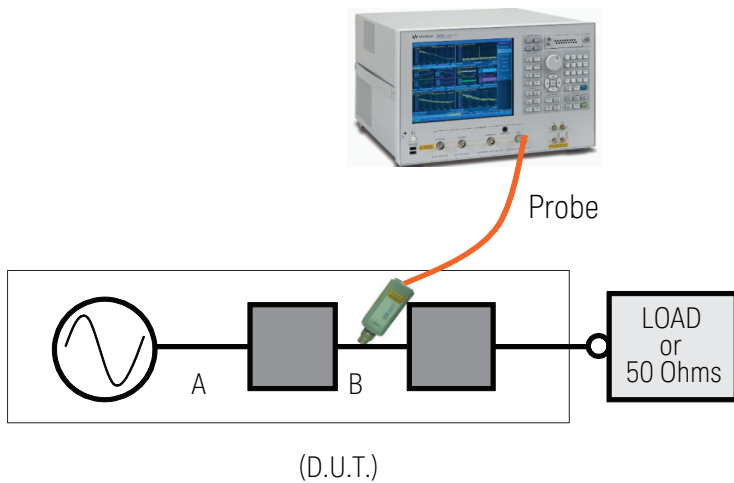

Figure 3. Test setup for phase noise and jitter measurement with signal source analyzers

Specifications

Specifications refer to the performance standards or limits against which the active differential probes are tested. Typical characteristics are included for additional information only and they are not specifications. These are denoted as “*typical*”, “*nominal*” or “*approximate*” and are printed in *italic*. (*Specifications subject to change.*)

Specifications	U1818A/B with N5381A	U1818A/B with N5382A	U1818A/B with N5425A or N5426AA	U1818A/B with N5380A
Bandwidth ¹	100 kHz to 7 or 12 GHz	100 kHz to 7 or 12 GHz	100 kHz to 7 or 12 GHz	100 kHz to 7 or 12 GHz
Supplementary/Typical performances	U1818A/B with N5381A	U1818A/B with N5382A	U1818A/B with N5425A or N5426AA	U1818A/B with N5380A
Maximum CW input power	16 dBm	16 dBm	16 dBm	14 dBm
Output Impedance	50 ohm nominal			
DC biasing characteristic	+ 15V at 142 mA and -12.6 V at 12 mA			
Maximum DC input voltage	+/- 10 V	+/- 10 V	+/- 10 V	+/- 10 V
Single ended mode input impedance at 1 MHz	25 kohm	25 kohm	25 kohm	N/A
Differential mode input impedance at 1 MHz	50 kohm	50 kohm	50 kohm	N/A
Model capacitance between tips Cm	0.09 pF	0.09 pF	0.13 pF	N/A
Model capacitance between tip and ground Cg	0.26 pF	0.26 pF	0.4 pF	N/A
Differential mode capacitance Cdiff (Cm + Cg/2)	0.21 pF	0.33 pF	0.33 pF	N/A
Single ended mode capacitance Cse (Cm+Cg)	0.35 pF	0.53 pF	0.53 pF	N/A
Norminal probe attenuation	-10 dB	-10 dB	-10 dB	-6.9 dB
Output return loss	100 kHz to 7 GHz : =< -13 dB, 7 GHz to 12 GHz : =< - 8 dB			
Common mode rejection	< 2 GHz : 35 dB, 2 to 12 GHz : < 30 dB			< 2 GHz : 25 dB, 2 to 12 GHz : < 15 dB
Noise spectral density ²	100 kHz to 10 MHz : <120 dBm/Hz, 10 MHz to 1 GHz : < -130 dBm/Hz 1 GHz to 12 GHz: < -145 dBm/Hz			
Noise figure ³	100 kHz to 10 MHz : <54 dB, 10 MHz to 1 GHz : < 44 dB, 1 GHz to 12 GHz: <29 dB			
Spurious ⁴	<2 MHz : -80 dBm			
Harmonic distortion (dBc) ⁵	< -40 dBc at +10 dBm input power for frequency < 5 GHz			< -35 dBc at +10 dBm input power for frequency at 2 GHz , < -35 dBc at + 4 dBm input power for frequency at 4 GHz, < -35 dBc at +2 dBm input power for frequency at 5 GHz
P1dB compression	Input power >10 dBm at frequency < 7 GHz			Input power >10 dBm at <=2 GHz
Phase noise at +5 dBm input power ⁵	Fc= 2 GHz at 1 MHz offset < -140 dBc/Hz			

1. Normalized 3 dB BW to 100 kHz.
2. Measured using “Noise Marker Function” of PSA E4440A Option 110 with pre-amp ON.
3. Noise figure reading is derived from noise spectrum density.
4. No spurious signal detected >2 MHz.
5. The signal source used is PSG.

Specifications (continued)

Supplementary/Typical performances	U1818A/B with N5381A	U1818A/B with N5382A	U1818A/B with N5425A or N5426AA	U1818A/B with N5380A
Phase noise at +10 dBm input power ¹		Fc= 100 MHz at 1 MHz offset < -135 dBc/Hz		Fc=100 MHz at 1 MHz offset < -140 dBc/Hz
Calculated jitter: Fc=2 GHz at +5 dBm input power ²		5 kHz to 20 MHz : 31 fs		5 kHz to 20 MHz : 25 fs
Calculated jitter: Fc=100 MHz at +10 dBm input power ²		5 kHz to 20 MHz : 1100 fs		5 kHz to 20 MHz : 601 fs
ESD			> 8 kV	

1. The signal source used is PSG.
2. The jitter value depends on the PSG and the U1818A/B probe. At close-in offset frequency, the residual noise of the probe is better. The PSG calculated jitter is 23 fs.

Jitter

Table 1. Jitter performance of the U1818A/B measured with N5381A probe head (typical)

Frequency	100 MHz			1 GHz			2 GHz			5 GHz		
RF input	-5 dBm	0 dBm	5 dBm	-5 dBm	0 dBm	5 dBm	-5 dBm	0 dBm	5 dBm	-5 dBm	0 dBm	5 dBm
Measure carrier	-15.3 dBm	-10.3 dBm	-5.3 dBm	-16 dBm	-11 dBm	-6.2 dBm	-17 dBm	-12 dBm	-7.2 dBm	-17.3 dBm	12.3 dBm	-6.9 dBm
RMS jitter bandwidth	RMS jitter (fsec)			RMS jitter (fsec)			RMS jitter (fsec)			RMS jitter (fsec)		
100 Hz to 100 MHz	8500	4800	2800	331	0 dBm	118	131	86	63	44	33	29
20 kHz to 80 MHz	8500	4800	2800	308	171	55	125	77	55	38	28	24
5 kHz to 20 MHz	5900	3300	1900	141	82	56	66	42	31	27	24	22
100 Hz to 10 KHz	150	100	81	16.7	15.5	15	13	15	14	16	15	14

Table 2. Jitter performance of the U1818A/B measured with N5380A probe head (typical)

Frequency	100 MHz			1 GHz			2 GHz			5 GHz		
RF input	-5 dBm	0 dBm	5 dBm	-5 dBm	0 dBm	5 dBm	-5 dBm	0 dBm	5 dBm	-5 dBm	0 dBm	2 dBm
Measure carrier	-11.2 dBm	-6.25 dBm	-1.2 dBm	-11.2 dBm	-6.3 dBm	-1.3 dBm	-10.8 dBm	-5.9 dBm	-0.9 dBm	-11.3 dBm	-6.3 dBm	-3.2 dBm
RMS jitter bandwidth	RMS jitter (fsec)			RMS jitter (fsec)			RMS jitter (fsec)			RMS jitter (fsec)		
100 Hz to 100 MHz	3860	2200	1340	245	137	96	75	52	47	29	26	24
20 kHz to 80 MHz	3850	2190	1337	208	122	86	67	46	41	25	22	20
5 kHz to 20 MHz	2600	1.5	940	106	64	47	37	27	25	22	21	21
100 Hz to 10 KHz	93	75	70	13	12	11	11	11	10	12	11.8	13

Harmonics

Table 3. Harmonics of the U1818A/B measured with N5381A, N5382A and N5425A probe heads (typical)

Input Power	Fundamental Frequency	2nd Harmonic	3rd Harmonic
+10dBm	100 MHz	-52 dBc	-49 dBc
	1 GHz	-45 dBc	-50 dBc
	2 GHz	-58 dBc	-51 dBc
	4 GHz	-62 dBc	-47 dBc
	5 GHz	-45 dBc	-61 dBc

Table 4. Harmonics of the U1818A/B measured with N5380A probe head (typical)

Input Power	Fundamental Frequency	2nd Harmonic	3rd Harmonic
+10dBm	100 MHz	-36 dBc	-36 dBc
	1 GHz	-47 dBc	-39 dBc
	2 GHz	-43 dBc	-40 dBc
+4 dBm	4 GHz	-39 dBc	-35 dBc
+2 dBm	5 GHz	-35 dBc	-36 dBc

Environmental Specifications

Temperature	
Operating	0 to +55 °C
Storage	-40 °C to 70 °C
Error corrected range	23 °C to ±3 °C
Cycling	-65 °C to + 85 °C, 10 cycles at 20 °C per minute, 20 minutes dwell time per MIL-STD-883F, Method 1010.8, Condition C (modified)
Relative humidity	
Operation	50 to 90% RH at 40 °C, 24 hours cycling, repeated 5 times
Storage	90% RH at 65 °C, one 24 hour cycle
Shock	
End-use handling shock	Half-sine wave form, 2-3 ms duration, 60 in/s (1.6 ms) delta-V
Transportation shock	Trapezoidal wave form, 18-22 ms duration, 337 in/s (8.56 ms) delta-V
Vibration	
Operating	Random: 5-500 Hz, 0.21 grms, 10 min/axis
Survival	Random: 5-500 Hz, 2.09 grms, 10 min/axis Swept Sine: 5-500 Hz, 0.5 grms, 10 min/axis, 4 resonance search, 10 min dwell
Altitude	
Operating	< 4,572 meters (15,000 feet)
Storage	< 15,000 meters (50,000 feet)
ESD immunity	
Direct discharge*	8.0 kV per IEC 61000-4-2
Air discharge	15 kV per IEC 61000-4-2

* To outer conductor

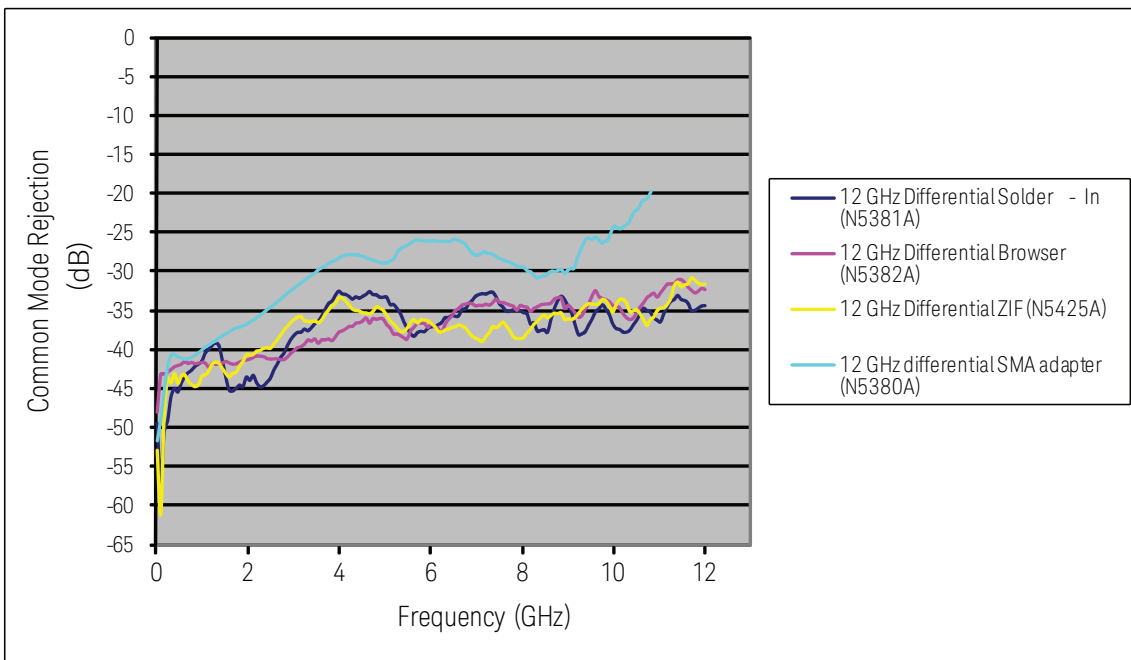

Figure 4. Keysight U1818A/B common mode rejection versus frequency (typical)

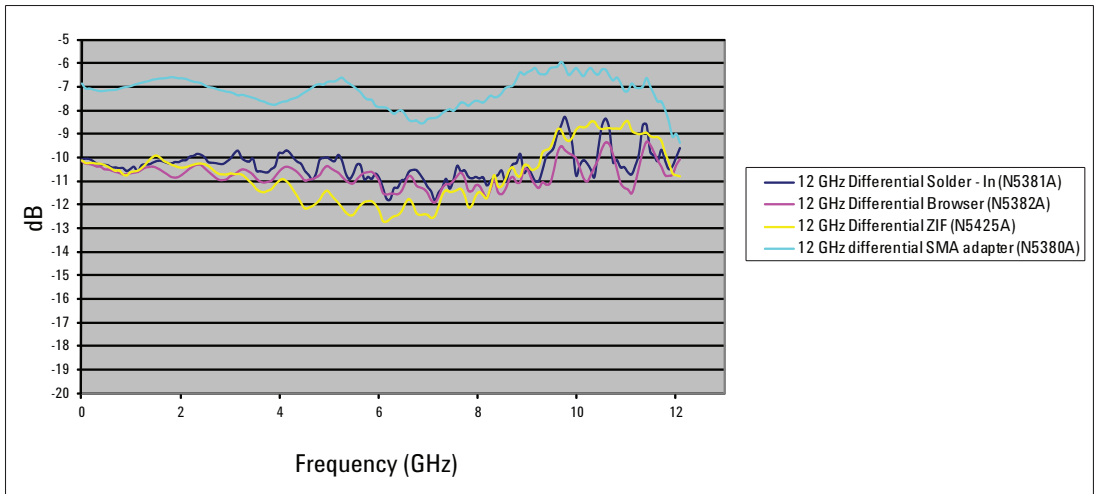

Figure 5. Keysight U1818A/B frequency response (typical)

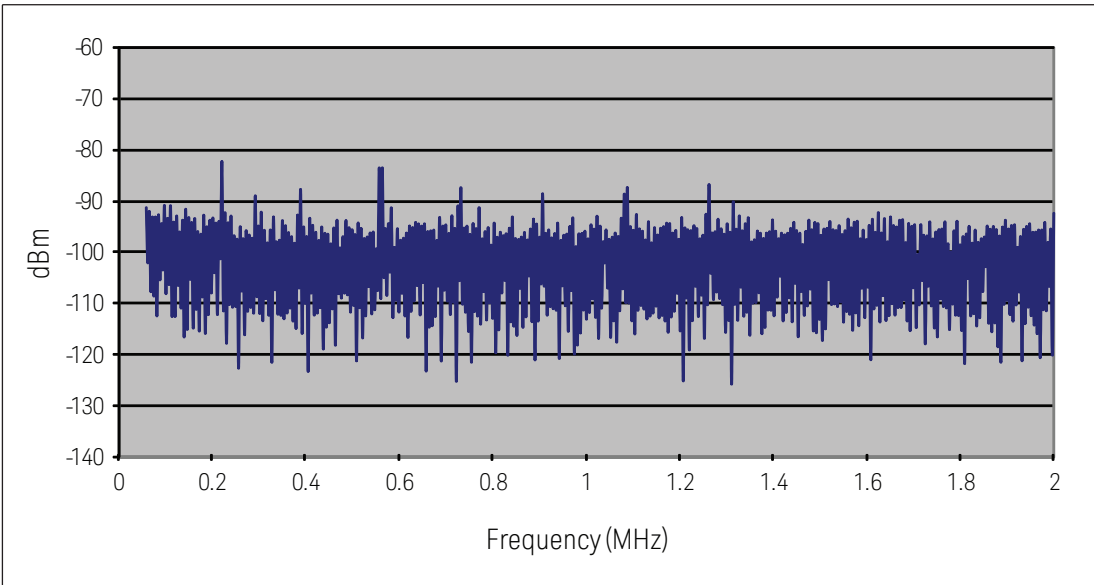

Figure 6. Keysight U1818A/B spurious versus frequency (typical)

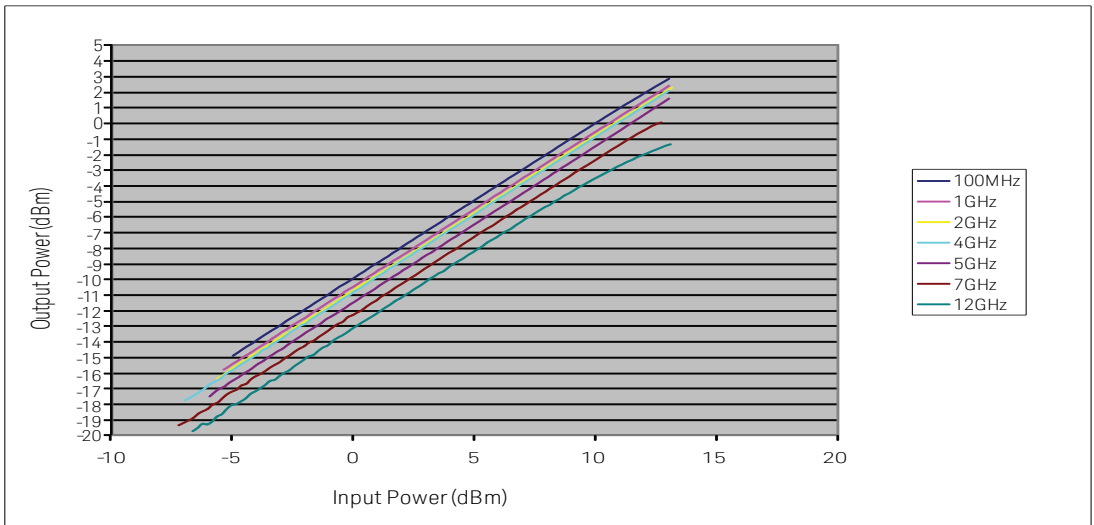

Figure 7. U1818A/B P1 dB, measured with N5381A probe head (typical)

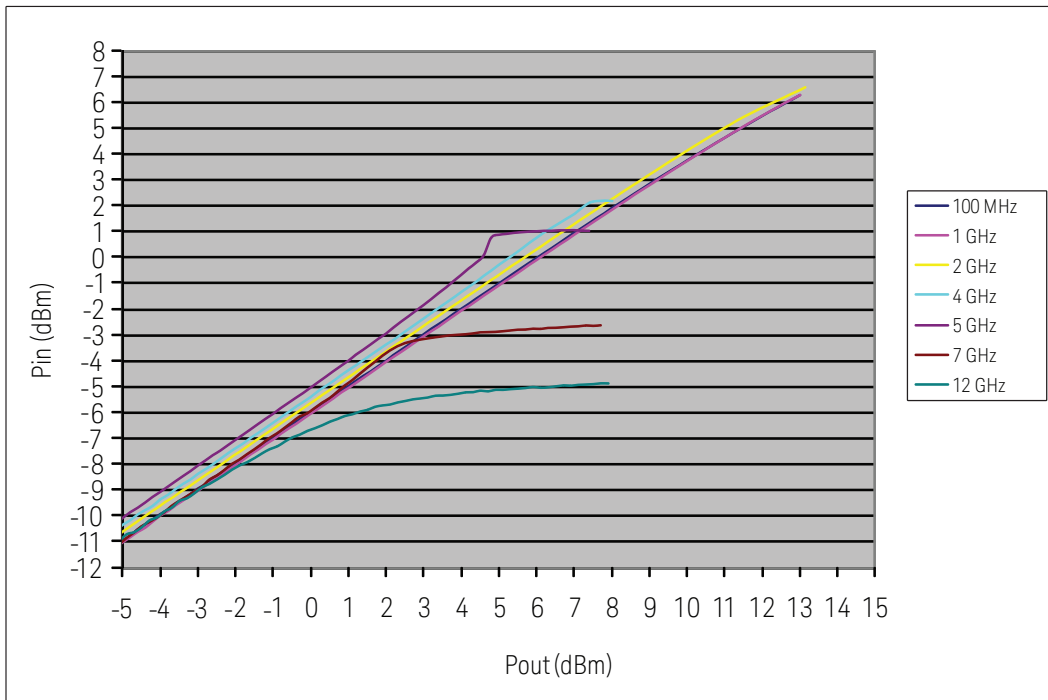

Figure 8. U1818A/B P1 dB, measured with N5380A probe head (typical)

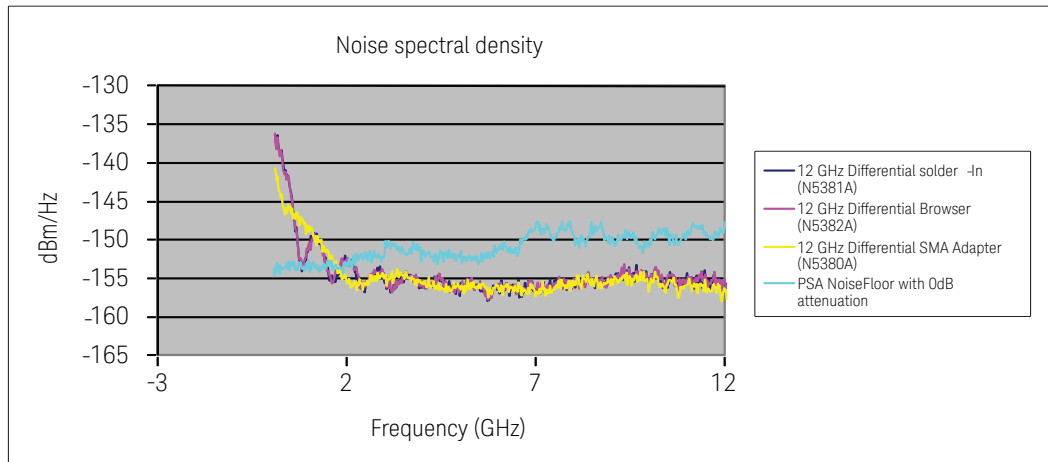

Figure 9. U1818A/B noise spectral density versus frequency (typical)

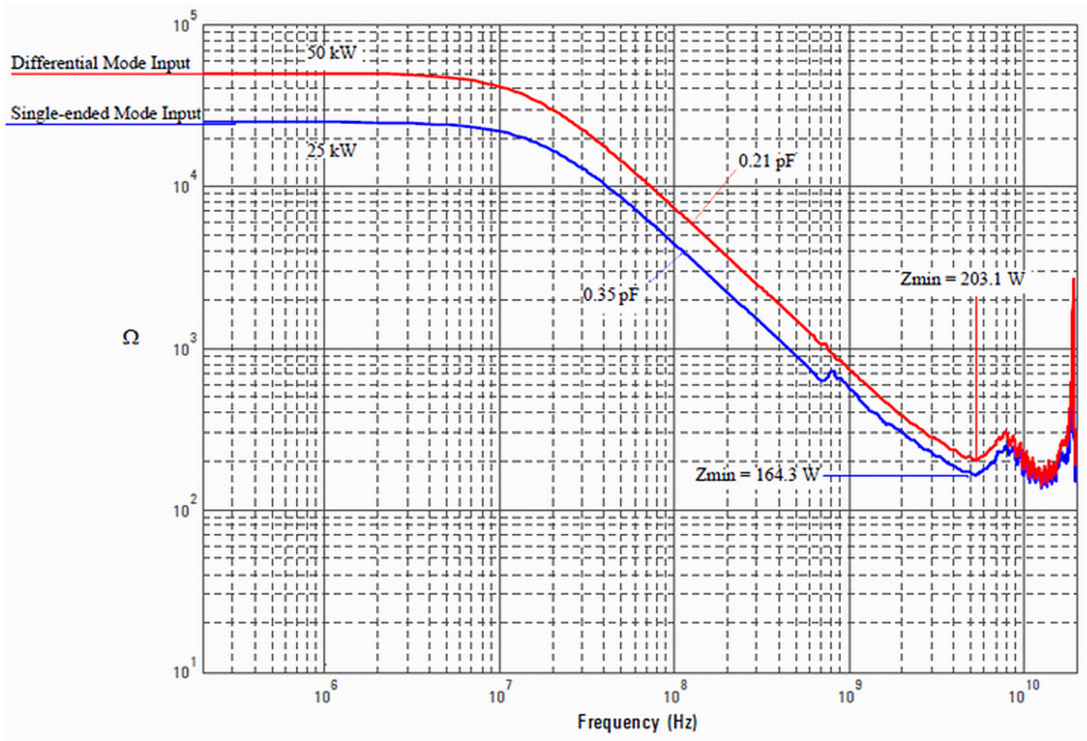

Figure 10. N5381A and N5382A probe heads input impedance versus frequency (typical)

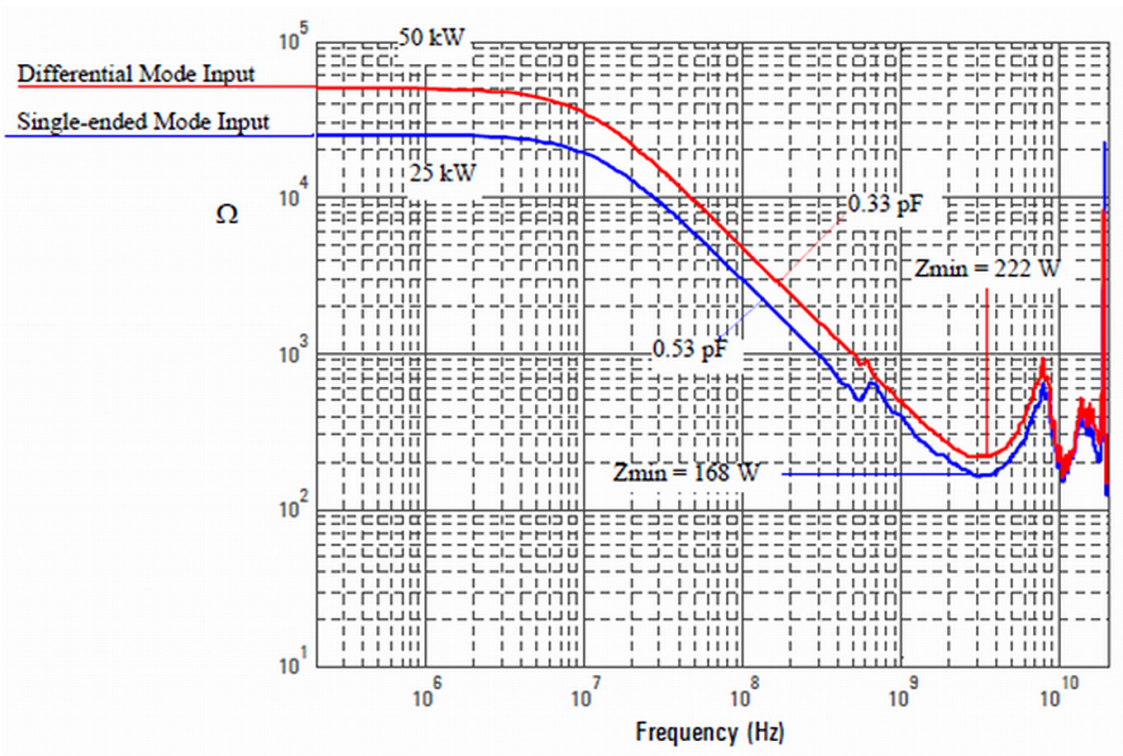

Figure 11. N5425A probe heads input impedance versus frequency (typical)

Mechanical Dimension*

U1818A/B	
Mechanical Dimension	Figure 12
Connector Type	N-Type (m)
Weight	0.170 kg (0.236 lb)
Shipping Weight	1.135 kg (2.502 lb)

*Dimensions are in mm [inches] nominal, unless otherwise specified

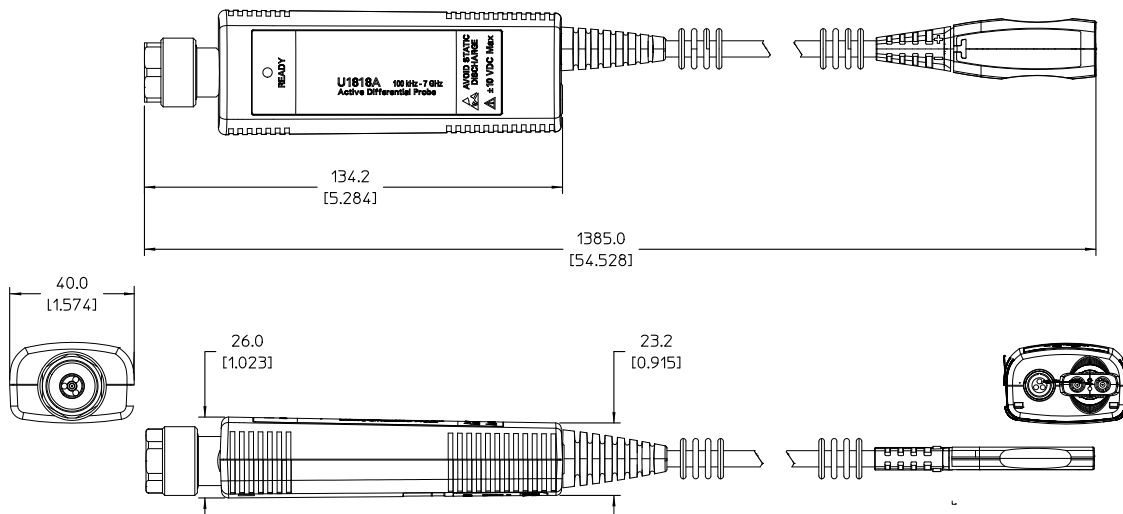

Figure 12. U1818A/B mechanical dimensions

Ordering Information¹

- U1818A 100 kHz to 7 GHz active differential probe
- U1818B 100 kHz to 12 GHz active differential probe
 - Option 001 Cable assembly – power probe cable
 - Option 002 Cable assembly – banana plug

Probe Head

- E2695A Differential SMA probe head for InfiniiMax probe
- N5380A InfiniiMax II 12 GHz differential SMA adapter
- N5381A 12 GHz InfiniiMax differential solder-in probe head
- N5382A InfiniiMax II 12 GHz differential browser
- N5425A 12 GHz InfiniiMax ZIF-solder-in probe head
- N5426A 12 GHz InfiniiMax ZIF Tip –kit of 10

Related Accessories

- 11852B Minimum loss attenuator pad
- E2676A 6 GHz InfiniiMax single-end browser probe head
- N2784A 1-arm probe positioner
- N2785A 2-arm probe positioner
- N2787A 3D probe positioner
- N2880A In-line attenuator kit
- N2881A DC blocking capacitor
- N5450A InfiniiMax extreme temperature cable extension

Recommended Power Supplies

- E3620A 50 W Dual Output Power Supply
- For a complete list of power supplies go to www.keysight.com/find/DCPowerSupplies

Related Literature

High Frequency Probing Solutions for Time and Frequency Domain Applications, 5990-4387EN

1. The U1818A/B are shipped with a protective casing

Evolving Since 1939

Our unique combination of hardware, software, services, and people can help you reach your next breakthrough. We are unlocking the future of technology.

From Hewlett-Packard to Agilent to Keysight.



myKeysight

myKeysight

www.keysight.com/find/mykeysight

A personalized view into the information most relevant to you.

http://www.keysight.com/find/emt_product_registration

Register your products to get up-to-date product information and find warranty information.

KEYSIGHT SERVICES

Accelerate Technology Adoption.
Lower costs.

Keysight Services

www.keysight.com/find/service

Keysight Services can help from acquisition to renewal across your instrument's lifecycle. Our comprehensive service offerings—one-stop calibration, repair, asset management, technology refresh, consulting, training and more—helps you improve product quality and lower costs.

For other unlisted countries:

www.keysight.com/find/contactus
(BP-9-7-17)



Keysight Assurance Plans

www.keysight.com/find/AssurancePlans

Up to ten years of protection and no budgetary surprises to ensure your instruments are operating to specification, so you can rely on accurate measurements.

DEKRA Certified
ISO 9001 Quality Management System

www.keysight.com/go/quality

Keysight Technologies, Inc.
DEKRA Certified ISO 9001:2015
Quality Management System

Keysight Channel Partners

www.keysight.com/find/channelpartners

Get the best of both worlds: Keysight's measurement expertise and product breadth, combined with channel partner convenience.

www.keysight.com/find/mta

www.keysight.com/find/RFprobes

This information is subject to change without notice.

© Keysight Technologies, 2017
Published in USA, December 1, 2017
5990-4148EN
www.keysight.com



Ihr Ansprechpartner /
Your Partner:

dataTec AG

E-Mail: info@datatec.eu

>>> www.datatec.eu



Premium Plus Distribution Partner