



# PXIe-LCR5101 Bundle

Expandable PXI bundle based on PXIe-4190 LCR  
Meter and SMU, 500 kHz, +/- 10 V

## Specifications

PXIe-1083 and PXIe-4190



Ihr Ansprechpartner /  
Your Partner:

**dataTec AG**  
E-Mail: [info@datatec.eu](mailto:info@datatec.eu)  
>>> [www.datatec.eu](http://www.datatec.eu)

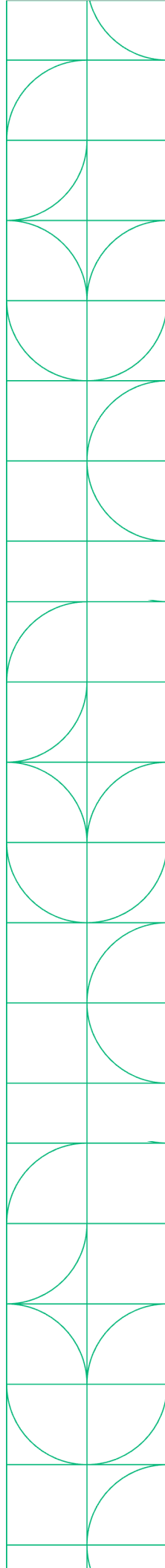

# PXI LCR Bundle

## In the Box

	<b>PXIe-LCR5101 Bundle</b>	<b>Accessories:</b>
<b>PXIe-4190</b> (LCR Meter)		<ul style="list-style-type: none"><li>• DSUB to BNC cable</li><li>• Thunderbolt cable</li><li>• Power cable (varied by PN)<ul style="list-style-type: none"><li>○ 867126-01 (US)</li><li>○ 867126-02 (EUR)</li><li>○ 867126-03 (Generic)</li></ul></li></ul>
	<b>PXIe-1083</b> (5-Slot PXIe Chassis)	

## Recommended Software

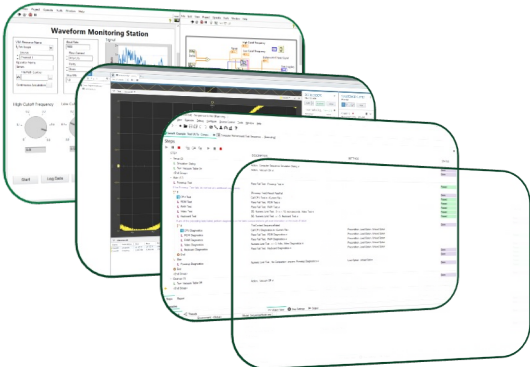
<b>Test Workflow</b> P/N: 788509-35	Test Workflow is a bundle of select NI software featuring engineering-specific tools that help test professionals accomplish anything from their day-to-day work to overcoming their most challenging obstacles.
	Test Workflow includes: <ul style="list-style-type: none"><li>• <b>LabVIEW</b> - a graphical programming environment engineers use to develop automated research, validation, and production test systems.</li><li>• <b>InstrumentStudio</b> - an application software that provides an integrated approach to interactive PXI measurements.</li><li>• <b>TestStand</b> - a test executive software that accelerates system development and deployment for engineers in validation and production.</li><li>• And more NI Software!</li></ul>

## Table of Contents

This document combines the PDFs of this bundle together. The page numbers in the table of contents correspond to the page number of PDF the component's documentation begins.

PXIe-1083 Specifications.....	3
PXIe-4190 Specifications.....	16



---

# PXIe-1083

## Specifications

---



# PXIe-1083 Specifications

This document contains specifications for the PXIe-1083 chassis.

## Electrical

The following section provides information about the PXIe-1083 AC input and DC output.

### AC Input

Input rating	100 VAC to 240 VAC, 50 Hz/60 Hz, 6 A to 3 A
Operating voltage range <sup>1</sup>	90 VAC to 264 VAC
Nominal input frequency	50 Hz/60 Hz
Operating frequency range <sup>1</sup>	47 Hz to 63 Hz
Efficiency	78% typical
Over-current protection	Internal fuse in line
Main power disconnect	The AC power cable provides main power disconnect. Do not position the equipment so that it is difficult to disconnect the power cord. The front-panel power switch causes the internal chassis power supply to provide DC power to the PXI Express backplane.



Caution Disconnect power cord to completely remove power.

## DC Output

DC output characteristics of the PXIe-1083.

Voltage Rail	Maximum Current	Load Regulation	Maximum Ripple and Noise (20 MHz BW)
+5V_AUX	1.0 A	±5%	50 mVpp
+12 V	30.1 A	±5%	120 mVpp
+5 V	25.1 A	±5%	50 mVpp
+3.3 V	30.7 A	±5%	50 mVpp
-12 V	0.75 A	±5%	120 mVpp

Maximum total available power for the PXIe-1083 is 293 W.

The maximum combined power available on +3.3 V and +5 V is 180 W.

The maximum power available for each Thunderbolt port is 15 W (5 V/3 A).

Table 1. Backplane Slot Current Capacity

Slot	+5 V	V (I/O)	+3.3 V	+12 V	-12 V	5 V <sub>AUX</sub>
Hybrid Peripheral Slot with PXI-5 Peripheral	-	-	3 A	6 A	-	1 A
Hybrid Peripheral Slot with PXI-1 Peripheral	6 A	5 A	6 A	1 A	1 A	-



**Note** PCI V(I/O) pins in Hybrid Peripheral Slots are connected to +5 V.



**Note** The maximum power dissipated in a peripheral slot should not exceed 58 W. Refer to the **Operating Environment** section for ambient temperature considerations at 58 W.

Over-current protection	All outputs are protected from short circuit and overload, they recover and return to regulation when the overload is removed and the power is cycled.
Over-voltage protection	+3.3 V clamped at 3.7 V to 4.3 V, +5 V clamped at 5.7 V to 6.5 V, +12 V clamped at 13.4 V to 15.6 V

## Chassis Cooling

Module cooling	Forced air circulation (positive pressurization) through one 150 CFM fan
Module slot airflow direction	Bottom of module to top of module
Module intake	Bottom of chassis
Module exhaust	Top, right side of chassis
Slot cooling capacity	58 W; slot 6 supports 58 W cooling with high fan mode
Power supply cooling	Forced air circulation through integrated fans
Power supply intake	Front and left side chassis
Power supply exhaust	Rear of chassis
<b>Minimum chassis cooling clearances</b>	
Above	44.45 mm (1.75 in.)
Rear	44.45 mm (1.75 in.)
Sides	44.45 mm (1.75 in.)
<b>Below</b>	
Rack	44.45 mm (1.75 in.)
Desktop	25.4 mm (1.00 in.)

## Environmental

Maximum altitude	2,000 m (6,560 ft.), 800 mbar (at 25 °C ambient, high fan mode)
Pollution Degree	2

Indoor use only.

## Operating Environment

<b>Ambient temperature range</b>	
When all peripheral modules require $\leq 38$ W cooling capacity per slot	0 °C to 50 °C (IEC 60068-2-1 and IEC 60068-2-2.) <sup>2</sup> Meets MIL-PRF-28800F Class 3 low temperature limit and high temperature limit.
When any peripheral module requires $> 38$ W cooling capacity per slot	0 °C to 40 °C (IEC 60068-2-1 and IEC 60068-2-2.) <sup>2</sup> Meets MIL-PRF-28800F Class 3 low temperature limit and MIL-PRF-28800F Class 4 high temperature limit.
Relative humidity range	20% to 80%, noncondensing

## Storage Environment

Ambient temperature range	-40 °C to 71 °C (IEC-60068-2-1 and IEC-60068-2-2.) <sup>[3]</sup> Meets MIL-PRF-28800F Class 3 limits.
Relative humidity range	10% to 95%, noncondensing

## Shock and Vibration

Operational shock	30 g peak, half-sine, 11 ms pulse (IEC-60068-2-27.) <sup>3</sup> Meets MIL-PRF-28800F Class 2 limits.
Operational random vibration	5 to 500 Hz, 0.3 g <sub>rms</sub>
Non-operating vibration	5 to 500 Hz, 2.4 g <sub>rms</sub> (IEC 60068-2-64.) <sup>3</sup> Non-operating test profile exceeds the requirements of MIL-PRF-28800F, Class 3.

## Acoustic Emissions

### Sound Pressure Level (at Operator Position)

(Tested in accordance with ISO 7779. Meets MIL-PRF-28800F requirements.)

#### 38 W Profile

Auto fan (up to 30 °C ambient)	33.7 dBA
High fan	50.8 dBA

#### 58 W Profile

Auto fan (up to 30 °C ambient)	54.7 dBA
High fan	55.3 dBA

## Sound Power Level

#### 38 W Profile



Auto fan (up to 30 °C ambient)	44.9 dBA
High fan	60.3 dBA

**58 W Profile**

Auto fan (up to 30 °C ambient)	63.4 dBA
High fan	64.2 dBA



**Note** The protection provided by the PXIe-1083 can be impaired if it is used in a manner not described in this document.

## Safety Compliance Standards

This product is designed to meet the requirements of the following electrical equipment safety standards for measurement, control, and laboratory use:

- IEC 61010-1, EN 61010-1
- UL 61010-1, CSA C22.2 No. 61010-1



**Note** For safety certifications, refer to the product label or the [Product Certifications and Declarations](#) section.

## EMC Guidelines

This product was tested and complies with the regulatory requirements and limits for electromagnetic compatibility (EMC) stated in the product specifications. These requirements and limits provide reasonable protection against harmful interference when the product is operated in the intended operational electromagnetic environment.

This product is intended for use in industrial locations. However, harmful interference may occur in some installations, when the product is connected to a peripheral device or test object, or if the product is used in residential areas. To minimize interference with radio and television reception and prevent unacceptable performance degradation, install and use this product in strict accordance with the instructions in the product documentation.

Furthermore, any changes or modifications to the product not expressly approved by NI could void your authority to operate it under your local regulatory rules.

## EMC Notices

Refer to the following notices for cables, accessories, and prevention measures necessary to ensure the specified EMC performance.



### Notice

For EMC declarations and certifications, and additional information, refer to the [Product Certifications and Declarations](#) section.



**Notice** Changes or modifications to the product not expressly approved by NI could void your authority to operate the product under your local regulatory rules.



**Notice** Operate this product only with shielded cables and accessories.

## Electromagnetic Compatibility Standards

This product meets the requirements of the following EMC standards for electrical equipment for measurement, control, and laboratory use:

- EN 61326-1 (IEC 61326-1): Class A emissions; Basic immunity
- EN 55011 (CISPR 11): Group 1, Class A emissions

- AS/NZS CISPR 11: Group 1, Class A emissions



**Note** Group 1 equipment (per CISPR 11) is any industrial, scientific, or medical equipment that does not intentionally generate radio frequency energy for the treatment of material or inspection/analysis purposes.



**Note** In Europe, Canada, Australia, and New Zealand (per CISPR 11) Class A equipment is intended for use in nonresidential locations.

## CE Compliance

This product meets the essential requirements of applicable European Directives, as follows:

- 2014/35/EU; Low-Voltage Directive (safety)
- 2014/30/EU; Electromagnetic Compatibility Directive (EMC)
- 2011/65/EU; Restriction of Hazardous Substances (RoHS)

## Product Certifications and Declarations

Refer to the product Declaration of Conformity (DoC) for additional regulatory compliance information. To obtain product certifications and the DoC for NI products, visit [ni.com/product-certifications](http://ni.com/product-certifications), search by model number, and click the appropriate link.

## Environmental Management

NI is committed to designing and manufacturing products in an environmentally responsible manner. NI recognizes that eliminating certain hazardous substances from our products is beneficial to the environment and to NI customers.

For additional environmental information, refer to the **Engineering a Healthy Planet** web page at [ni.com/environment](http://ni.com/environment). This page contains the environmental

regulations and directives with which NI complies, as well as other environmental information not included in this document.

## EU and UK Customers

-  Waste Electrical and Electronic Equipment (WEEE)—At the end of the product life cycle, all NI products must be disposed of according to local laws and regulations. For more information about how to recycle NI products in your region, visit [ni.com/environment/weee](https://ni.com/environment/weee).

## 电子信息产品污染控制管理办法 ( 中国 RoHS )

-  中国 RoHS— NI 符合中国电子信息产品中限制使用某些有害物质指令(RoHS)。关于 NI 中国 RoHS 合规性信息，请登录 [ni.com/environment/rohs\\_china](https://ni.com/environment/rohs_china)。(For information about China RoHS compliance, go to [ni.com/environment/rohs\\_china](https://ni.com/environment/rohs_china).)

## Backplane

Size	3U-sized; 5 peripheral slots. Compliant with IEEE 1101.10 mechanical packaging. PXI Express Specification compliant. Accepts both PXI Express and CompactPCI (PICMG 2.0 R 3.0) 3U modules.
Backplane bare-board material	UL 94 V-0 Recognized
Backplane connectors	Conforms to IEC 917 and IEC 1076-4-101, UL 94 V-0 rated

## System Synchronization Clocks

10 MHz System Reference Clock: PXI\_CLK10

Maximum slot-to-slot skew	250 ps
Accuracy	$\pm 25$ ppm max (guaranteed over the operating temperature range)
Maximum jitter	5 ps RMS phase-jitter (10 Hz–1 MHz range)
Duty-factor	45% to 55%
Unloaded signal swing	3.3 V $\pm$ 0.3 V



Note For other specifications, refer to the **PXI-1 Hardware Specification**.

### 100 MHz System Reference Clock: PXIe\_CLK100 and PXIe\_SYNC100

Maximum slot-to-slot skew	100 ps
Accuracy	$\pm 25$ ppm max (guaranteed over the operating temperature range)
Maximum jitter	3 ps RMS phase-jitter (10 Hz to 12 kHz range), 2 ps RMS phase-jitter (12 kHz to 20 MHz range)
Duty-factor for PXIe_CLK100	45% to 55%
Absolute differential voltage (When terminated with a 50 $\Omega$ load to 1.30 V or Thévenin equivalent)	400 mV to 1000 mV



Note For other specifications, refer to the **PXI-5 PXI Express Hardware Specification**.

## Mechanical

<b>Standard chassis dimensions</b>	
Height	177.1 mm (6.97 in.)
Width	257.1 mm (10.12 in.)
Depth	214.2 mm (8.43 in.)
Weight	6.7 kg (14.8 lb)
Chassis materials	Extruded Aluminum (6063-T5, 6060-T6), Cold Rolled Steel/Stainless Steel, Santoprene, Urethane Foam, PC-ABS, Nylon, Polyethylene
Finish	Conductive Clear Iridite on Aluminum, Electroplated Nickel on Cold Rolled Steel, Electroplated Zinc on Cold Rolled Steel

The following figures show the PXIe-1083 chassis dimensions. The holes shown are for installing the optional rack mount kits.

Figure 1. PXIe-1083 Chassis Dimensions (Front)

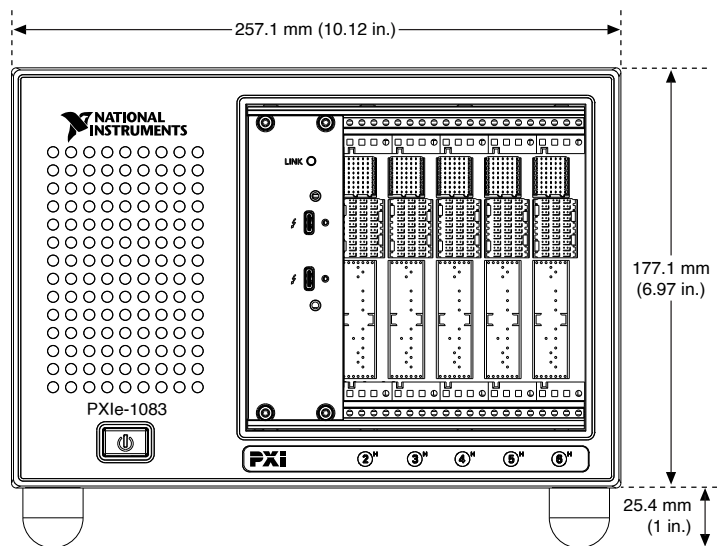

Figure 2. PXIe-1083 Chassis Dimensions (Side)

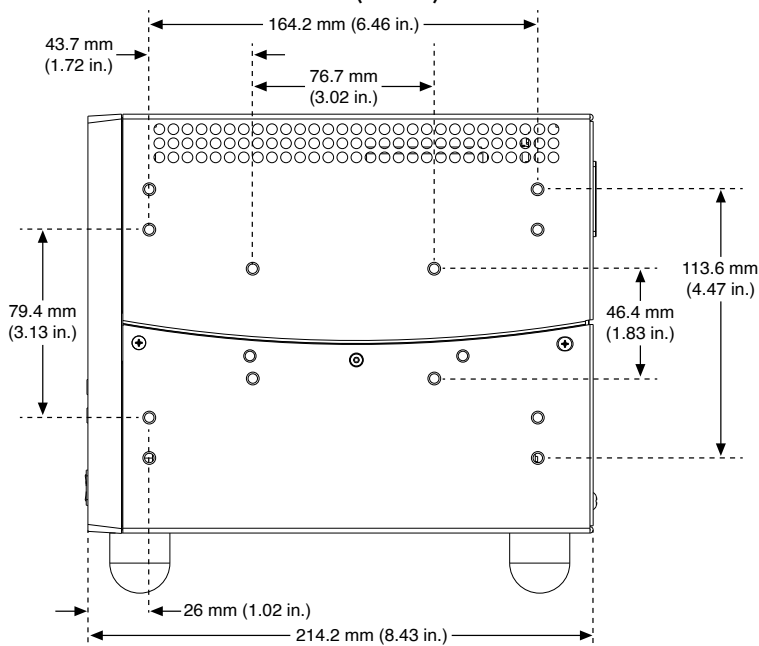
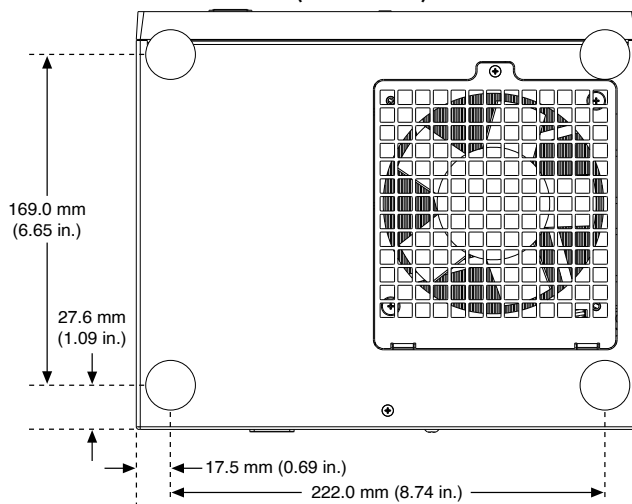

Figure 3. PXIe-1083 Chassis Dimensions (Bottom)



<sup>1</sup> The operating range is guaranteed by design.

<sup>2</sup> This product meets the requirements of the environmental standards for electrical equipment for measurement, control, and laboratory use.

<sup>3</sup> This product meets the requirements of the environmental standards for electrical equipment for measurement, control, and laboratory use.

---

# PXIe-4190

## Specifications

---





# PXIe-4190 Specifications

## Notes on PXIe-4190 Variants

In this document, the 500 kHz and 2 MHz variants of the PXIe-4190 are referred to inclusively as the PXIe-4190. The information in this document applies to all variants of the PXIe-4190 unless otherwise specified.

To determine which version of the PXIe-4190 you have, locate the device name in one of the following places:

- On the device front panel.
- In MAX, the PXIe-4190 (2 MHz) appears as **NI PXIe-4190**. The PXIe-4190 (500 kHz) appears as **NI PXIe-4190 (500 kHz)**.

## Definitions

**Warranted** specifications describe the performance of a model under stated operating conditions and are covered by the model warranty.

**Characteristics** describe values that are relevant to the use of the model under stated operating conditions but are not covered by the model warranty.

- **Typical** specifications describe the performance met by a majority of models.
- **Nominal** specifications describe an attribute that is based on design, conformance testing, or supplemental testing.

Specifications are **Warranted** unless otherwise noted.

## SMU Specifications

### SMU Specifications Conditions

The following conditions must be met when operating in SMU Mode.

- Ambient temperature<sup>[1]</sup> of  $23\text{ °C} \pm 5\text{ °C}$
- Relative humidity between 10% and 60%, noncondensing
- Chassis with slot cooling capacity  $\geq 58\text{ W}$
- Calibration interval of 1 year
- 30 minutes warm-up time
- Self-calibration performed within the last 24 hours
- NI-DCPower 21.8 or later installed
- Connections between force and sense leads are required and must be made while the **niDCPower Output Enabled** or **niDCPower Output Connected** properties are set to FALSE<sup>[2]</sup>
- **niDCPower Aperture Time** property or **NIDCPOWER\_ATTR\_APERTURE\_TIME** attribute set to 2 power-line cycles (PLC)
- **niDCPower Cable Length** property or **NIDCPOWER\_ATTR\_CABLE\_LENGTH** attribute set when using the lower two current ranges

# SMU Instrument Capabilities

## PXIe-4190 (500 kHz)

DC voltage ranges	1 V 10 V
DC current ranges	10 $\mu$ A 100 $\mu$ A 1 mA 10 mA 100 mA
<b>Available DC output power</b>	
Sourcing	4 W
Sinking	4 W

Figure 2. PXIe-4190 (500 kHz) Quadrant Diagram

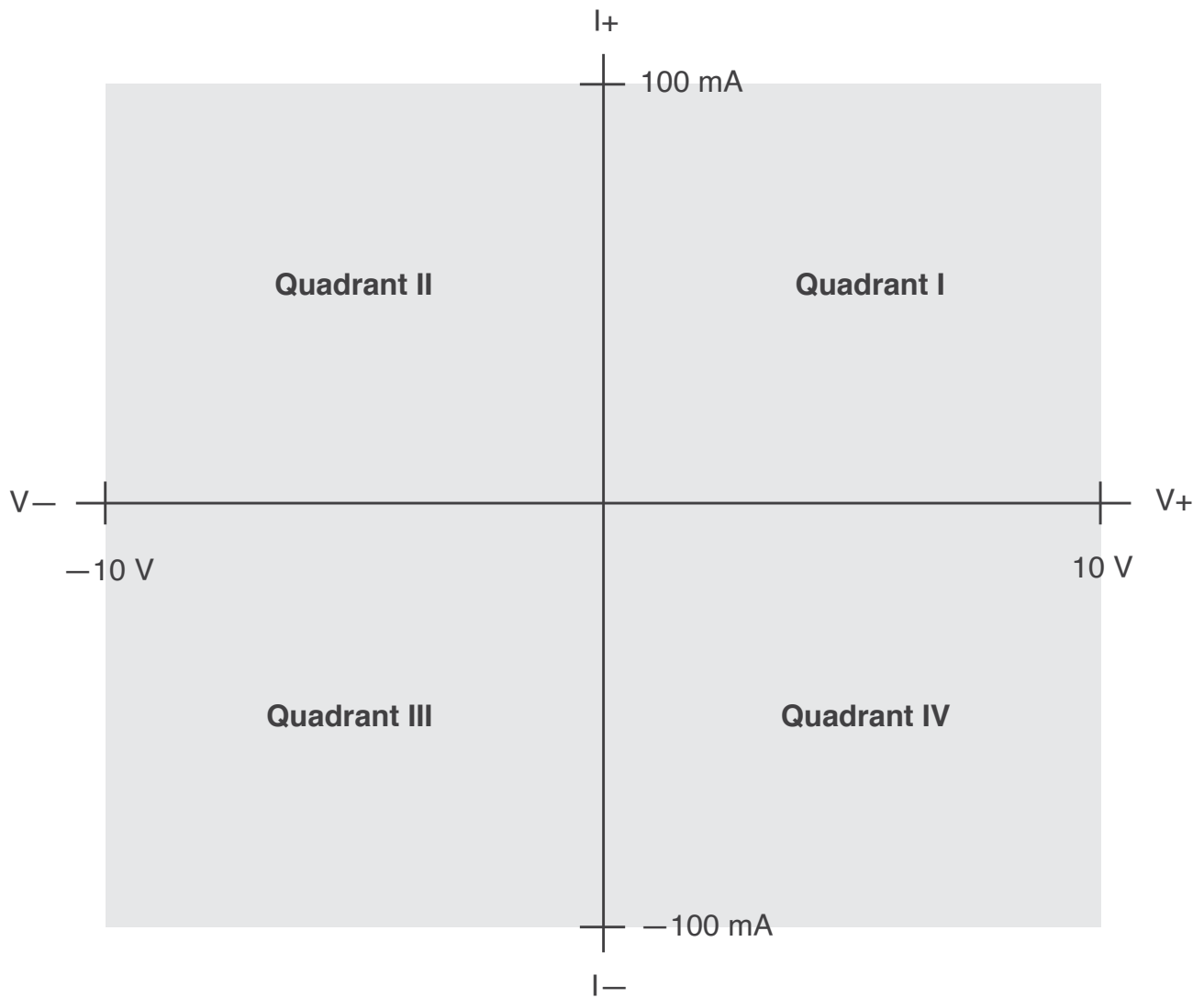

## SMU Voltage

Range	Resolution (Noise Limited)	Noise (0.1 Hz to 10 Hz, peak-to-peak, typical)	Accuracy $\pm$ (% of Voltage + Offset)		Tempco <sup>[3]</sup> $\pm$ (% of Voltage + Offset)/°C
			T <sub>ambient</sub> 23 °C $\pm$ 5 °C, T <sub>cal</sub> <sup>[4]</sup> $\pm$ 5 °C		
			% of Voltage	Offset	T <sub>ambient</sub> 0 °C to 30 °C, T <sub>cal</sub> $\pm$ 5 °C
1 V	100 nV	2 $\mu$ V	0.009%	160 $\mu$ V	0.0002% + 1 $\mu$ V
10 V	1 $\mu$ V	10 $\mu$ V	0.008%	1 mV	
40 V <sup>[5]</sup>	4 $\mu$ V	50 $\mu$ V	.009%	4.1 mV	

Table 1. Voltage Programming and Measurement Accuracy/Resolution

## SMU Current

Range	Resolution (Noise Limited)	Noise (0.1 Hz to 10 Hz, peak-to-peak, typical)	Accuracy $\pm$ (% of Current + Offset)		Tempco <sup>[6]</sup> $\pm$ (% of Current + Offset)/°C
			T <sub>ambient</sub> 23 °C $\pm$ 5 °C, T <sub>cal</sub> <sup>[7]</sup> $\pm$ 5 °C		
			% of Current	Offset <sup>+</sup>	T <sub>ambient</sub> 0 °C to 30 °C, T <sub>cal</sub> $\pm$ 5 °C
1 nA <sup>[7], [8]</sup>	1 fA	30 fA	0.14%	2 pA	0.0003% + 20 fA
1 nA <sup>[9], [8]</sup>		60 fA			
100 nA <sup>[7], [8]</sup>	10 fA	300 fA	0.091%	11 pA	
100 nA <sup>[9], [8]</sup>		700 fA			
1 $\mu$ A	100 fA	2 pA	0.032%	140 pA	
10 $\mu$ A	1 pA	15 pA	0.026%	1 nA	
100 $\mu$ A	10 pA	120 pA	0.024%	10 nA	
1 mA	100 pA	1.2 nA	0.023%	100 nA	
10 mA	1 nA	12 nA	0.022%	1 $\mu$ A	
100 mA	10 nA	120 nA	0.028%	10 $\mu$ A	

Range	Resolution (Noise Limited)	Noise (0.1 Hz to 10 Hz, peak-to- peak, typical)	Accuracy $\pm$ (% of Current + Offset)		Tempco <sup>[6]</sup> $\pm$ (% of Current + Offset)/ $^{\circ}$ C
			$T_{\text{ambient}} 23\text{ }^{\circ}\text{C} \pm 5\text{ }^{\circ}\text{C}, T_{\text{cal}} \pm 5\text{ }^{\circ}\text{C}$		
			% of Current	Offset <sup>+</sup>	$T_{\text{ambient}} 0\text{ }^{\circ}\text{C} \text{ to } 30\text{ }^{\circ}\text{C}, T_{\text{cal}} \pm 5\text{ }^{\circ}\text{C}$
<sup>+</sup> Add 10 pA to current accuracy specifications when using DSUB-DSUB cable accessory (SHDB13W6-DB13W6-LL)					

Table 2. Current Programming and Measurement Accuracy/Resolution

## SMU Noise

Wideband source noise	<20 mV pk-pk, typical <sup>[10]</sup>
-----------------------	---------------------------------------

## SMU Remote Sense

Maximum sense lead resistance	200 $\Omega$
Maximum lead drop per lead	1 V

## SMU Guard Output Characteristics

<b>Cable guard</b>	
Output impedance	<100 m $\Omega$ , nominal
Offset voltage	1 mV, typical

## SMU Measurement and Update Timing

Available sample rates <sup>[11]</sup>	(600 kS/s)/ <b>N</b> , nominal
--	--------------------------------

where

- **N** = 1, 2, 3, ... 2<sup>24</sup>

- S is samples

Sample rate accuracy	Equal to PXIe_CLK100 accuracy, nominal
Maximum measure rate to host	600 kS/s, nominal
<b>Input trigger to</b>	
Source event delay	10 $\mu$ s nominal
Source event jitter	2 $\mu$ s pk-pk, nominal
Measure event jitter	2 $\mu$ s pk-pk, nominal

<sup>1</sup> The ambient temperature of a PXI system is defined as the temperature at the chassis fan inlet (air intake).

<sup>2</sup> Disconnecting the sense leads while both these properties are set to TRUE may result in output protection errors or long settling tails due to the feedback path for the control loop being open. If the PXIe-4190 is run open loop due to accidental sense lead disconnection, allow a minimum of 1 minute after establishing proper lead connections before making measurements.

<sup>3</sup> Temperature coefficient applies beyond 23 °C  $\pm$ 5 °C ambient within  $\pm$ 5 °C of  $T_{cal}$ .

<sup>4</sup>  $T_{cal}$  is the internal device temperature recorded by the PXIe-4190 at the completion of the last self-calibration

<sup>5</sup> PXIe-4190 (2 MHz) only

<sup>6</sup> Temperature coefficient applies beyond 23 °C  $\pm$ 5 °C ambient within  $\pm$ 5 °C  $T_{cal}$ .

<sup>7</sup> Under the following additional conditions: with 10 PLC, and 11-point median filter.

<sup>8</sup> PXIe-4190 (2 MHz) only

<sup>9</sup> Under default specification conditions.

<sup>10</sup> 10 Hz to 20 MHz bandwidth, PXIe-4190 configured for normal transient response.

<sup>11</sup> When source-measuring, both the NI-DCPower **Source Delay** and **Aperture Time** properties affect the sampling rate. When taking a measure record, only the **Aperture Time** property affects the sampling rate.

## LCR Specifications

### LCR Specifications Conditions

The following conditions must be met when operating in LCR Mode.

- Ambient temperature<sup>[1]</sup> of  $23\text{ °C} \pm 5\text{ °C}$
- Relative humidity between 10% and 60%, noncondensing
- Chassis with slot cooling capacity  $\geq 58\text{ W}$
- Calibration interval of 1 year
- 30 minutes warm-up time
- Self-calibration performed within the last 24 hours
- NI-DCPower 21.8 or later installed
- Automatic Level Control (ALC) is On
- LCR Measurement Time is Long unless otherwise stated
- Open and short compensation has been completed
- Connections between force and sense leads are required and must be made while the **niDCPower Output Enabled** or **niDCPower Output Connected** properties are set to FALSE<sup>[2]</sup>
- Four-terminal pair (4TP) connections to load<sup>[3]</sup>
- **niDCPower Cable Length** property or **NIDCPOWER\_ATTR\_CABLE\_LENGTH** attribute set
- Impedance range is within 30% of DUT impedance
- Temperature is within  $\pm 5\text{ °C}$  of last self-calibration
- DC bias is off
- SHDB13W6-4BNCM-LL Cable, 1 m (NI part number 788280-01)

### LCR Instrument Capabilities

Maximum AC voltage	7.07 V RMS
Maximum AC current	70.7 mA RMS



Maximum DC bias voltage range - PXIe-4190 (2 MHz)	±40 V, including peak test signal
Maximum DC bias voltage range - PXIe-4190 (500 kHz)	±10 V, including peak test signal
Maximum DC bias current range	±100 mA, including peak test signal
<b>Measurement times</b>	
Short	1 ms
Medium	10 ms
Long	100 ms
Custom	User-defined

**Note** Measurement times round to the nearest positive integer number of cycles of the stimulus frequency.

## LCR Measurements

- **Z**—Impedance
- **Y**—Admittance
- **Ls**—Inductance using series-equivalent circuit model
- **Cs**—Capacitance using series-equivalent circuit model
- **Rs**—Resistance using series-equivalent circuit model
- **Lp**—Inductance using parallel-equivalent circuit model
- **Cp**—Capacitance using parallel-equivalent circuit model
- **Rp**—Resistance using parallel-equivalent circuit model
- **D**—Dissipation factor
- **Q**—Quality factor
- **V DC**—DC voltage measurement
- **I DC**—DC current measurement
- **AC voltage**—AC voltage magnitude and phase angle
- **AC current**—AC current magnitude and phase angle

## LCR Test Signal

### Voltage stimulus

Maximum	7.07 V RMS
Minimum	7.07 mV RMS
Resolution	<1 $\mu$ V RMS
Maximum current	70.7 mA RMS

### Accuracy (ALC on)

$\leq 10$ kHz	$\pm 0.2\%$
10 kHz to Maximum Frequency (500 kHz or 2 MHz)	$\pm 6\%$

### Current stimulus

Maximum	70.7 mA RMS
Minimum	707 nA RMS
Resolution	<100 pA RMS
Maximum voltage	7.07 V RMS

### Accuracy (ALC on)

$\leq 10$ kHz	$\pm 0.2\%$
10 kHz to Maximum Frequency (500 kHz or 2 MHz)	$\pm 6\%$

## LCR DC Bias

### Voltage DC bias - PXIe-4190 (500 kHz)

Maximum	±10 V, including peak AC signal
Resolution	<10 $\mu$ V
Accuracy	0.02% + 5 mV

### Current DC bias

Maximum	±100 mA, including peak AC signal
Resolution	<10 nA
Accuracy	0.04% + 10 $\mu$ A

## LCR Frequency

Accuracy	Equal to PXIe_CLK100 accuracy, nominal
----------	--

## LCR Measurement Accuracy

Impedance Range	Frequency						
	40 Hz to 100 Hz	100 Hz to 1 kHz	1 kHz to 10 kHz	10 kHz to 200 kHz	200 kHz to 500 kHz	500 kHz to 1 MHz <sup>[4]</sup>	1 MHz to 2 MHz <sup>[4]</sup>
100 M $\Omega$ to 1 G $\Omega$	1.00%	1.00%	—	—	—	—	—
10 M $\Omega$ to 100 M $\Omega$	0.15%	0.15%	0.15%	—	—	—	—
1 M $\Omega$ to 10 M $\Omega$	0.06%	0.06%	0.15%	0.30%	—	—	—
100 k $\Omega$ to 1 M $\Omega$	0.05%	0.05%	0.08%	0.30%	0.30%*	0.30% <sup>†</sup>	0.60% <sup>†</sup>
10 k $\Omega$ to 100 k $\Omega$	0.05%	0.05%	0.08%	0.30%	0.30%	0.30%	0.60%
1 k $\Omega$ to 10 k $\Omega$	0.05%	0.05%	0.08%	0.20%	0.20%	0.20%	0.50%
300 $\Omega$ to 1 k $\Omega$	0.08%	0.08%	0.08%	0.20%	0.20%	0.50%	1.60%
10 $\Omega$ to 300 $\Omega$	0.80%	0.80%	0.80%	0.90%	0.90%	1.20%	2.00%

**Note:** When on boundary, use lower adjacent value.

\* Up to 640 k $\Omega$  impedance range.

<sup>†</sup> Up to 255 k $\Omega$  impedance range.

Impedance Range	Frequency						
	40 Hz to 100 Hz	100 Hz to 1 kHz	1 kHz to 10 kHz	10 kHz to 200 kHz	200 kHz to 500 kHz	500 kHz to 1 MHz <sup>[4]</sup>	1 MHz to 2 MHz <sup>[4]</sup>

‡ Up to 130 k $\Omega$  impedance range.

Table 3. Absolute Impedance Magnitude Accuracy, 708 mV RMS to 7.07 V RMS Stimulus Voltage

Impedance Range	Frequency						
	40 Hz to 100 Hz	100 Hz to 1 kHz	1 kHz to 10 kHz	10 kHz to 200 kHz	200 kHz to 500 kHz	500 kHz to 1 MHz <sup>[5]</sup>	1 MHz to 2 MHz <sup>[5]</sup>
10 M $\Omega$ to 100 M $\Omega$	0.20%	0.40%	1.10%	—	—	—	—
1 M $\Omega$ to 10 M $\Omega$	0.06%	0.06%	0.20%	0.90%	—	—	—
100 k $\Omega$ to 1 M $\Omega$	0.05%	0.05%	0.08%	0.90%	0.60%*	0.60%†	0.60%‡
10 k $\Omega$ to 100 k $\Omega$	0.05%	0.05%	0.08%	0.30%	0.30%	0.30%	0.50%
1 k $\Omega$ to 10 k $\Omega$	0.05%	0.05%	0.08%	0.20%	0.20%	0.20%	0.50%
300 $\Omega$ to 1 k $\Omega$	0.08%	0.08%	0.08%	0.20%	0.20%	0.20%	1.60%
10 $\Omega$ to 300 $\Omega$	0.80%	0.80%	0.80%	0.90%	0.90%	1.20%	2.00%

**Note:** When on boundary, use lower adjacent value.

\* Up to 640 k $\Omega$  impedance range.

† Up to 255 k $\Omega$  impedance range.

‡ Up to 130 k $\Omega$  impedance range.

Table 4. Absolute Impedance Magnitude Accuracy, 150 mV RMS to 707 mV RMS Stimulus Voltage

	10 $\Omega$ to 300 $\Omega$	300 $\Omega$ to 10 M $\Omega$	10 M $\Omega$ to 100 M $\Omega$
50 mV RMS to 150 mV RMS	1	2	3
7.08 mV RMS to 50 mV RMS, typical	2	11	—

**Note:** Absolute accuracy is the **Absolute Impedance Magnitude Accuracy, 150 mV RMS to 707 mV RMS Stimulus Voltage** table value times the respective multiplier.

Table 5. Absolute Impedance Magnitude Accuracy Multiplier for Stimuli Below 150 mV RMS

Impedance Range	Frequency						
	40 Hz to 100 Hz	100 Hz to 1 kHz	1 kHz to 10 kHz	>10 kHz to 200 kHz	200 kHz to 500 kHz	500 kHz to 1 MHz <sup>[6]</sup>	1 MHz to 2 MHz <sup>[6]</sup>
100 MΩ to 1 GΩ	0.55 °	0.55 °	—	—	—	—	—
10 MΩ to 100 MΩ	0.19 °	0.08 °	0.25 °	—	—	—	—
1 MΩ to 10 MΩ	0.02 °	0.03 °	0.21 °	0.19 °	—	—	—
100 kΩ to 1 MΩ	0.01 °	0.02 °	0.19 °	0.19 °	0.14 °*	0.16 °†	0.26 °‡
10 kΩ to 100 kΩ	0.01 °	0.02 °	0.10 °	0.11 °	0.12 °	0.13 °	0.26 °
1 kΩ to 10 kΩ	0.01 °	0.02 °	0.09 °	0.10 °	0.10 °	0.12 °	0.31 °
300 Ω to 1 kΩ	0.01 °	0.03 °	0.12 °	0.08 °	0.13 °	0.21 °	0.34 °
10 Ω to 300 Ω	0.01 °	0.03 °	0.13 °	0.08 °	0.09 °	0.11 °	0.15 °

**Note:** When on boundary, use lower adjacent value.

\* Up to 640 kΩ impedance range.

† Up to 255 kΩ impedance range.

‡ Up to 130 kΩ impedance range.

Table 6. Absolute Impedance Phase Accuracy, 708 mV RMS to 7.07 V RMS Stimulus Voltage

Impedance Range	Frequency						
	40 Hz to 100 Hz	100 Hz to 1 kHz	1 kHz to 10 kHz	>10 kHz to 200 kHz	200 kHz to 500 kHz	500 kHz to 1 MHz <sup>[7]</sup>	1 MHz to 2 MHz <sup>[7]</sup>
10 MΩ to 100 MΩ	0.14 °	0.30 °	0.50 °	—	—	—	—
1 MΩ to 10 MΩ	0.03 °	0.03 °	0.14 °	0.45 °	—	—	—
100 kΩ to 1 MΩ	0.02 °	0.03 °	0.14 °	0.45 °	0.22 °*	0.22 °†	0.34 °‡
10 kΩ to 100 kΩ	0.01 °	0.02 °	0.07 °	0.15 °	0.14 °	0.14 °	0.34 °
1 kΩ to 10 kΩ	0.01 °	0.02 °	0.07 °	0.15 °	0.09 °	0.11 °	0.20 °
300 Ω to 1 kΩ	0.01 °	0.02 °	0.07 °	0.08 °	0.09 °	0.12 °	0.34 °
10 Ω to 300 Ω	0.01 °	0.04 °	0.22 °	0.08 °	0.10 °	0.13 °	0.18 °

**Note:** When on boundary, use lower adjacent value.

\* Up to 640 kΩ impedance range.

† Up to 255 kΩ impedance range.

Impedance Range	Frequency						
	40 Hz to 100 Hz	100 Hz to 1 kHz	1 kHz to 10 kHz	>10 kHz to 200 kHz	200 kHz to 500 kHz	500 kHz to 1 MHz <sup>[7]</sup>	1 MHz to 2 MHz <sup>[7]</sup>
‡ Up to 130 kΩ impedance range.							

Table 7. Absolute Impedance Phase Accuracy, 150 mV RMS to 707 mV RMS Stimulus Voltage

	10 Ω to 300 Ω	300 Ω to 1 kΩ	1 kΩ to 10 kΩ	>10 kΩ to 100 kΩ	100 kΩ to 1 MΩ	1 MΩ to 10 MΩ	10 MΩ to 100 MΩ
50 mV RMS to 150 mV RMS	2	2	2	2	2	2	3
7.08 mV RMS to 50 mV RMS, typical	20	70	25	25	10	8	8
<b>Note:</b> Absolute accuracy is the <b>Absolute Impedance Phase Accuracy, 150 mV RMS to 707 mV RMS Stimulus Voltage</b> table value times the respective multiplier.							

Table 8. Absolute Impedance Phase Accuracy Multiplier for Stimuli Below 150 mV RMS

<sup>1</sup> The ambient temperature of a PXI system is defined as the temperature at the chassis fan inlet (air intake).

<sup>2</sup> Disconnecting the sense leads while both these properties are set to TRUE may result in output protection errors or long settling tails due to the feedback path for the control loop being open. If the PXIe-4190 is run open loop due to accidental sense lead disconnection, allow a minimum of 1 minute after establishing proper lead connections before making measurements.

<sup>3</sup> Refer to the **PXIe-4190 Getting Started** for more information on 4TP connections.

<sup>4</sup> PXIe-4190 (2 MHz) only

<sup>5</sup> PXIe-4190 (2 MHz) only

<sup>6</sup> PXIe-4190 (2 MHz) only

<sup>7</sup> PXIe-4190 (2 MHz) only

## General Specifications

### Isolation

Isolation voltage, any pin to earth ground	40 V DC, Measurement Category I, functional
--	---

**Note** Pins are functionally isolated from chassis ground to prevent ground loops, but do not meet IEC 61010-1 for safety isolation.

**Note** The PXIe-4190 contains an internal switch controlled by the **niDCPower Isolation State** property or the **NIDCPOWER\_ATTR\_ISOLATION\_STATE** attribute that can connect the GUARD terminal to chassis ground and prevent the module output from floating. Isolation ratings only apply when this property/attribute is set to **Isolated**.

### Protection

#### Absolute maximum voltage

Output HI/Output LO/Sense HI/Sense LO to Output HI/Output LO/Sense HI/Sense LO	±42 V
Output HI/Sense HI to GUARD/Isolated Shield	± 6 V
GUARD/Isolated Shield to Chassis GND	±42 V

#### Absolute maximum current

All terminals	±150 mA
---------------	---------

#### Output channel protection

##### Output HI to GUARD/Isolated Shield

Overvoltage	Automatic output disable
-------------	--------------------------

##### Output LO to all terminals

Overcurrent Automatic output disable

### Sense HI/Sense LO to all terminals

Overcurrent Current limiter protects inputs up to absolute maximum voltage specification

Overtemperature Automatic output disable

## Physical Characteristics

Dimensions	3U, one-slot, PXI Express/CompactPCI Express module 2.0 cm x 13.0 cm x 21.6 cm (0.8 in. x 5.1 in. x 8.5 in.)
Weight	481 g (17.1 oz)
Front panel connectors	Custom 6 coaxial socket, 7 standard socket, mixed layout D-SUB, female

## Triggers

### Input triggers

Types Start  
Source  
Sequence Advance  
Measure

### Sources (PXI trigger lines 0 to 7)

Polarity Active high (not configurable)  
Minimum pulse width 100 ns

### Destinations<sup>[2]</sup> (PXI trigger lines 0 to 7)

Polarity Active high (not configurable)  
Minimum pulse width 200 ns

### Output triggers (events)



Types	Source Complete Sequence Iteration Complete Sequence Engine Done Measure Complete
-------	--

### Destinations (PXI trigger lines 0 to 7)<sup>[3]</sup>

Polarity	Active high (not configurable)
Pulse width	230 ns

## Calibration Interval

Recommended calibration interval	1 year
----------------------------------	--------

## Power Requirements

+3.3 V	1.0 A
+12 V	2.7 A

## Environmental Characteristics

### Temperature

Operating	0 °C to 55 °C <sup>[4]</sup>
Storage	-40 °C to 71 °C

### Humidity

Operating	10% RH to 90% RH, noncondensing <sup>[5]</sup>
Storage	5% RH to 95% RH, noncondensing

Pollution Degree	2
Maximum altitude	2,000 m (800 mbar) (at 25 °C ambient temperature)

**Shock and Vibration**

Operating vibration	5 Hz to 500 Hz, 0.3 g RMS
Non-operating vibration	5 Hz to 500 Hz, 2.4 g RMS
Operating shock	30 g, half-sine, 11 ms pulse

<sup>1</sup> Pulse widths and logic levels are compliant with **PXI Express Hardware Specification Revision 1.0 ECN 1**.

<sup>2</sup> Input triggers can come from any source (PXI trigger or software trigger) and be exported to any PXI trigger line. This allows for easier multi-board synchronization regardless of the trigger source.

<sup>3</sup> Pulse widths and logic levels are compliant with **PXI Express Hardware Specification Revision 1.0 ECN 1**.

<sup>4</sup> Not all chassis can achieve this ambient temperature range. Refer to PXI chassis specifications to determine the ambient temperature ranges your chassis can achieve.

<sup>5</sup> Accuracy specifications are only warranted for operating environments with temperatures below 30 °C and relative humidity levels below 60%. When transitioning the product from a storage or operating environment with relative humidity above 60%, you should allow the product to stabilize in the lower humidity environment for several hours before using it.



Ihr Ansprechpartner /  
Your Partner:

dataTec AG  
E-Mail: [info@datatec.eu](mailto:info@datatec.eu)  
>>> [www.datatec.eu](http://www.datatec.eu)

