



Ihr Ansprechpartner /  
Your Partner:

dataTec AG

E-Mail: [info@datatec.eu](mailto:info@datatec.eu)

>>> [www.datatec.eu](http://www.datatec.eu)

Mess- und Prüftechnik. Die Experten.



## DIGITAL POWER METER MODEL 66203/66204

Chroma 66203/66204 Power Meters are designed for multiple phase power measurement applications. The wiring mode function allows the user to take accurate power measurements for various wiring modes 1P2W/1P3W/3P3W/3P4W/3V3A as well as providing accurate standard power measurements common for most electrical devices. A unique feature of the 66203/66204 is its state-of-the-art DSP digitizing technology instead of less accurate and slower traditional analog circuits. The internal 16 bits analog/digital converters with sampling rates of up to 250kHz provide both high speed and high accuracy measurements which is unprecedented within the industry for this class of power meters.

The instruments include a four part display with 7-segment LED front panel readouts. Users can easily select desired parameters and readouts with a touch of a button. The 66203/66204 meters provide user with two standard versions for the remote interface (via rear panel connection) configured as USB with GPIB or USB with CAN.

The 66203/66204 are packaged in a 3U high, half rack enclosure suitable for bench top or system integration. The power meters are capable of supporting external shunts and CT for higher current application. The 4 channel 66204 is suitable for input and output parameter measurement and efficiency of 3 phase PV inverters can be calculated with measurement of the DC voltage/current at the input side of the inverter.

The 66203/66204 power meters include a 2-shunt design to provide high accurate readings for both low and high current measurements. The power meters also support features such as Inrush current, Total Harmonic Distortion of V/I, and Energy measurements. With these practical functions, the 66203/66204 power meters are suitable for meeting the demanding tasks of R&D, production and quality control departments.



## MODEL 66203/66204

### KEY FEATURES

- Voltage Ranges :  
15/30/60/150/300/600 Vrms,  
1200Vrms, 1800Vrms (optional kits)
- Current Ranges :  
0.005/0.02/0.05/0.2/0.5/2/5/20 Arms
- Frequency Range : DC, 10Hz~10kHz
- Embedded high speed DSP,  
16 bits Analog/Digital converters
- Half rack size, up to 4 input modules
- Supports various single and 3 phase wiring configurations (see diagram)
- Supports external shunt and CT for higher current applications
- 5 mA minimum current range & 0.1mW power resolution
- Meets ENERGY STAR / EN 50564 / IEC 62301 / ErP / SPEC Power
- Includes accumulated energy methods for unstable power measurement
- User-define criteria provides automatic PASS/FAIL indications
- Dual current shunt design provides high accuracy over a wide current range
- THD and user-specify order distortion measurement
- Inrush current and energy measurements
- Voltage / Current harmonics measurements up to 50 orders
- Support ultra high precision DCCT optional kit for high current measurement application



## FUNCTIONS AND APPLICATIONS

The multi-channel of 66203/66204 Power Meters are capable of supporting different wiring modes. As shown the instruments can be configured for single and 3 phase configurations by selection preset modes.



	Channel 1	Channel 2	Channel 3	Channel 4
1P2W (Single Phase Two Wire)	1P2W	1P2W	1P2W	1P2W
1P3W (Single Phase Three Wire)	1P3W		1P2W	1P2W
3P3W (Three Phase Three Wire-Two Watt Meter Method)	3P3W		1P2W	1P2W
3V3A (Three Phase Three Wire-Three Watt Meter Method)	3V3A			1P2W
3P4W (Three Phase Four Wire)	3P4W			1P2W

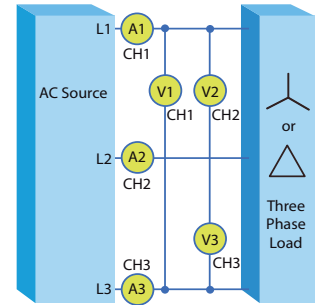

3V3A (Three Phase Three Wire)

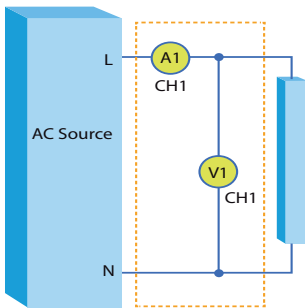

1P2W (Single Phase Two Wire)

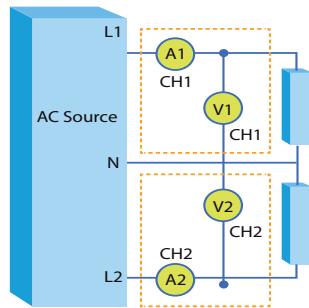

1P3W (Single Phase Three Wire)

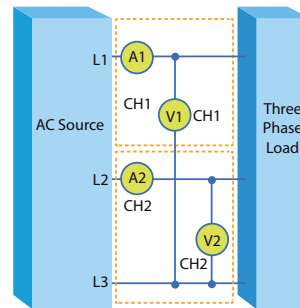

3P3W (Three Phase Three Wire)

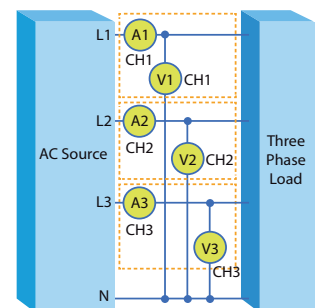

3P4W (Three Phase Four Wire)

Each channel of 66203/66204 has the ability to provide independent measurements; hence the meters are suitable for multi-point measurement applications such as PV inverter testing. Instruments are designed for measuring DC input parameters as well as three phase AC readings on the output side. The overall efficiency for the PV inverter can easily be obtained by built-in functions. In order to meet high voltage applications (up to 1800Vrms) Chroma offers an HV option kit.

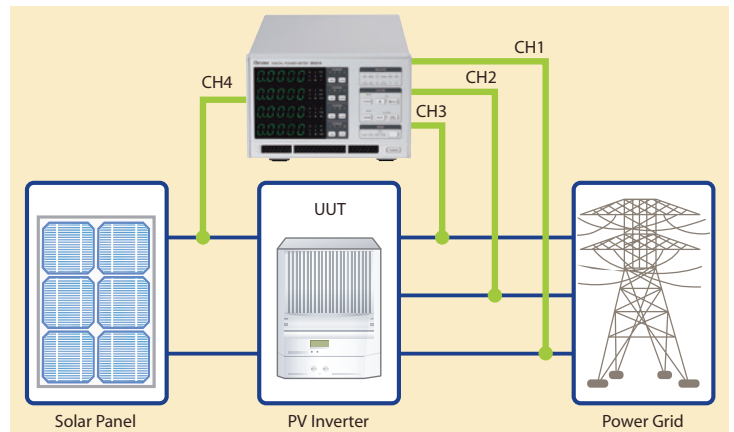

User could implement 3P3W (Three Phase Three Wire) wiring mode for three phase power measurement application. Such as Power Supplies.

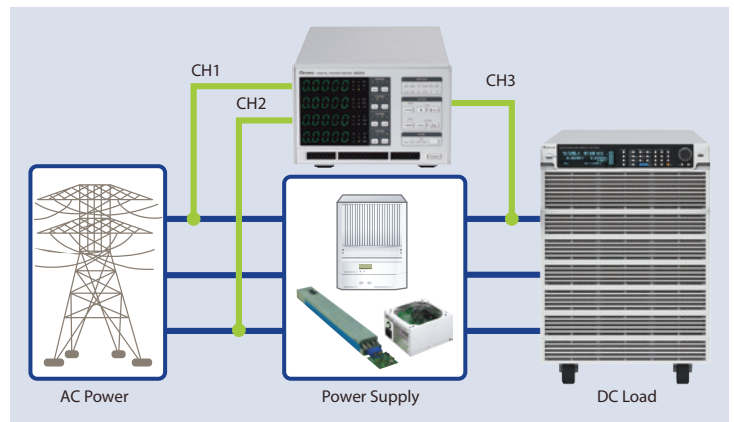

With the wiring mode set as 1P2W, the 66204 Power Meter has the capability of performing up to 4 simultaneous power measurements as shown. The meters are also designed to comply with power measurement requirements in accordance to many international standards such as Energy Star/EN 50564/IEC 62301/ErP.

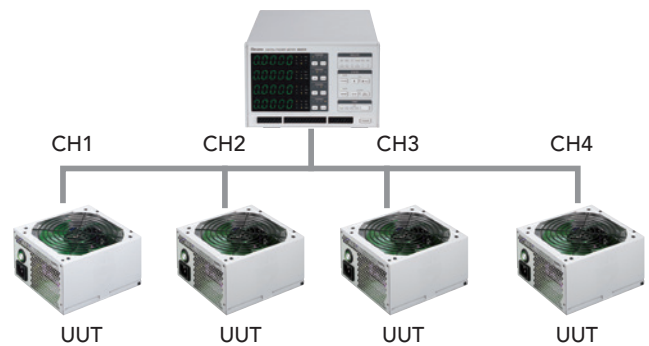

### User-defined Criteria for GO/NG Test

The Power Meters allow users to perform GO/NG functions by presetting pass/fail limits. If the measured values are within these limits, the Pass indicator illuminates green. Fail results in red illumination.

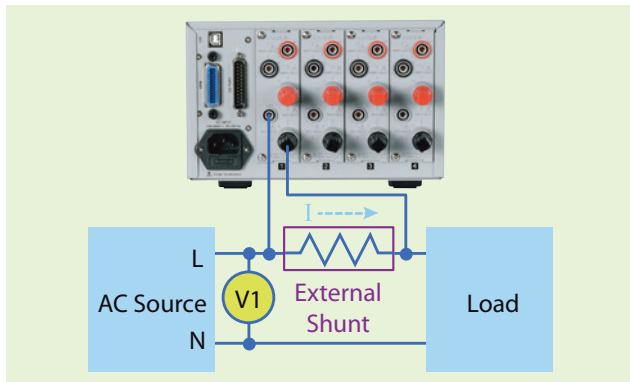

66203/66204 Power Meters support external shunt function for high current (>20A) measurement application.



Compact size design allows two 66203/66204 Power Meters to be configured side-by-side in a standard 19" rack

### Average Mode and Integration Mode for Power Measurement

When using a traditional power meter, unstable measurements can occur if the UUT's power consumption are unstable or operating in non-linear modes (i.e. a power supply's hiccup mode). In these cases the load levels maybe different at different measurement aperture windows (T1, T2, T3 and T4 below). A simple averaging calculation can only provide a visual stable value but provides inaccurate power readings.

The 66203/66204 includes a Window Mode method which calculates all data within the user-defined time window (Tw). In this manner users can obtain a real average value without data lose. An accumulated energy approach method (i.e. integration mode) for power measurements is also provided. This integration mode calculates active power values by integrating energy from V and I in a user-defined time period (Ti). In this way, users can achieve accurate readings with guaranteed transient-free variations. The 66203/66204 meters provide a 5mA minimum current range with crest factor 4, and 0.1mW measurement resolution for low power application (<10W), and less than 2% uncertainty even for No-Load mode power measurements. These functions make 66200 an ideal choice for ENERGY STAR / IEC 62301 / ErP / SPEC Power measurement.

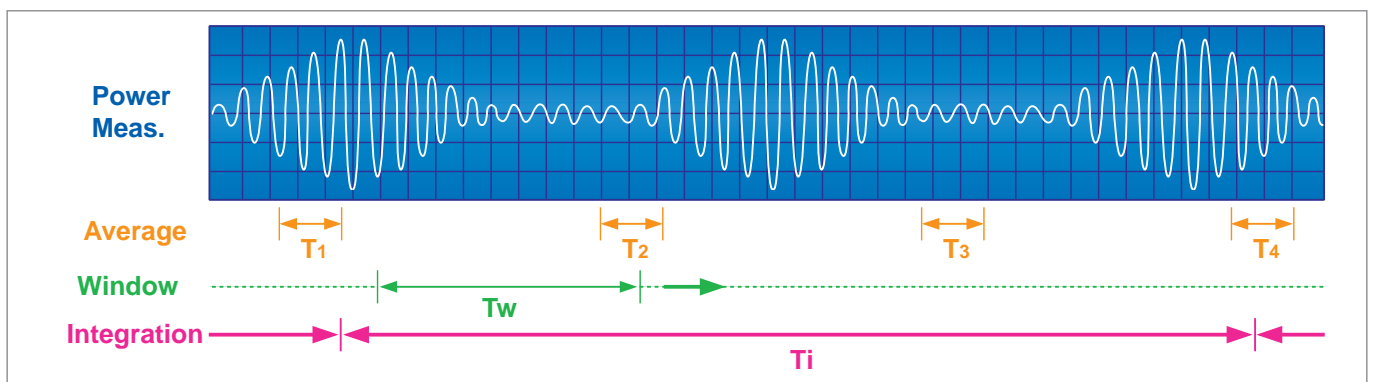

### THD Measurement and User Define Level of Distortion

The 66203/66204 Power Meters can measure voltage and current Total Harmonic Distortion (THD) directly which can be displayed in percentage format. For some requirements (ENERGY STAR), users need to verify the THD of AC supply voltage when supplying the UUT in the specified mode not to exceed 2%, up to and including the 13th harmonic (as specified in IEC 62301).

The 66203/66204 also provides a function to define a user-specify level of distortion  $n$ , ( $n$  is from 2 to 50) for measuring harmonic distortion. The calculation formula is listed below. Thus, the instrument can easily measure distortion values as required by the ENERGY STAR requirements.

$$THD_V = \frac{\sqrt{V_2^2 + V_3^2 + V_4^2 + V_5^2 + \dots + V_n^2}}{V_1}$$

Where  $V_n$  = rms value of  $n$ th harmonic of the voltage signal.

### Inrush Current Measurement

The 66203/66204 Power Meters include built-in inrush current ( $I_s$ ) measurement functions. Users can even set a current level for triggering the starting point of the measurement. Users also can use an external TTL signal to trigger inrush current measurements through the control I/O signal port located at the rear side.

The delay parameter can help users to bypass the peak value B after the trigger point A. The parameter,  $T$ , allows a set time period to be established for measuring the peak value during a preset time ( $T$ ). The main purpose is to avoid measuring the inrush current value that is generally caused by X-capacitor of a power supply.

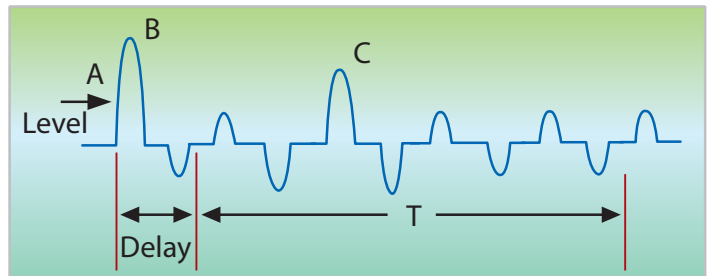

### Low Pass Filter

The maximum measurement bandwidth of the 66203/66204 Power Meters is 50kHz. However, the high frequency component is not desirable in all applications. For example, the input switching noise of some power supplies may influence the power measurement. In order to achieve a proper value, a low pass filter is necessary to reject the switching component. Users can set the parameter filter ON in the system configuration setting. The bandwidth will be reduced to 5kHz to reject high frequency content but still meets the 3kHz requirement of ENERGY STAR test.

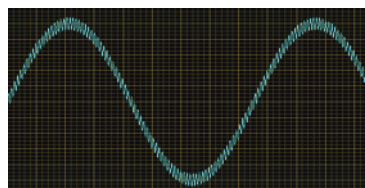
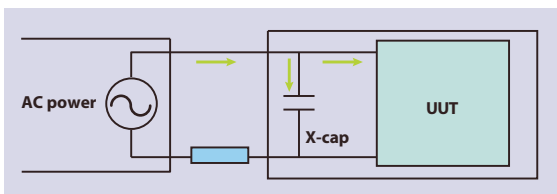

Filter Off : Bandwidth = 50kHz



Filter On: Bandwidth = 5kHz  
(meets the 3kHz requirement of Energy Star)

### Support Ultra High Precision Optional Kit for High Current Measurement Application

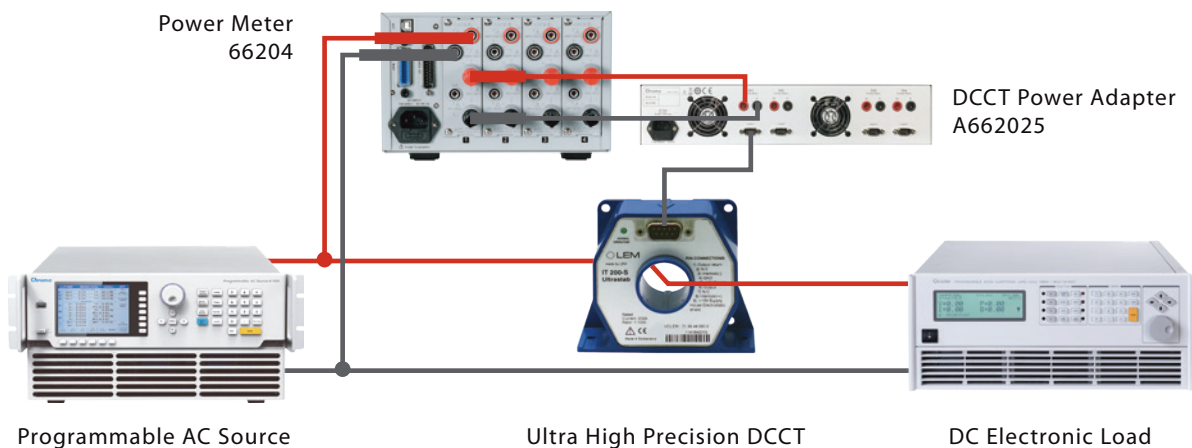

## POWER EFFICIENCY SOFTPANELS

The 66200 Power Meters provide graphical user interface software (Softpanels) which allow users to control and read measured parameters from a computer via USB or GPIB interface. Users can easily observe measured voltage and current waveforms and monitor the changes in parameter readings by using the chart function. Additional features include a recording function which can record selected parameters and write data to a file for further analysis. The 66200 Softpanels supports IEC 61000-3-2\* harmonic current limit test (pre-compliance) allowing users to examine whether the UUT has met the harmonic current requirement. The Power Efficiency Softpanel\* also integrates with Chroma's electronic loads and AC Sources to provide an easy method of power efficiency testing and recording of data using the test report function which automatically generates a report at the completion of testing.

(\*Only support by 1P2W with designated single channel)

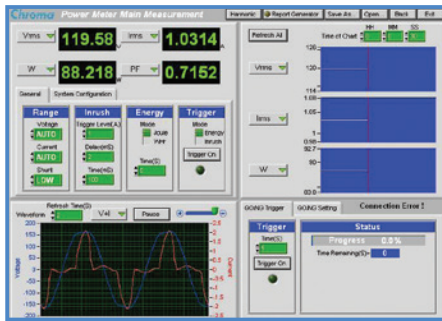

66200 Softpanel

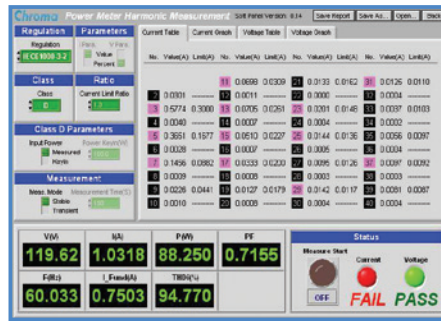

IEC 61000-3-2 Current Harmonics Test (Pre-compliance)



Power Efficiency Test Softpanel

## PANEL DESCRIPTION

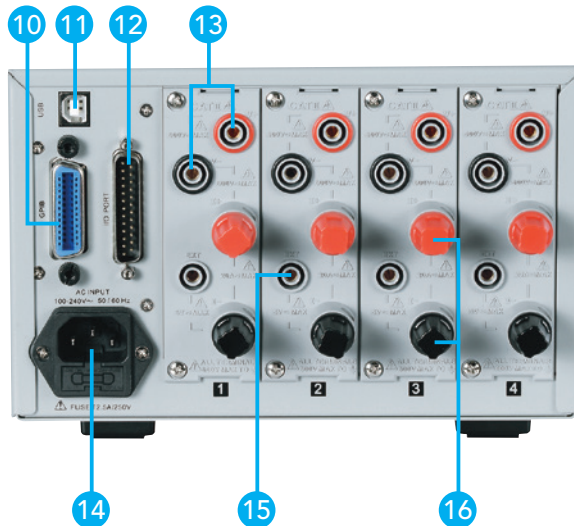
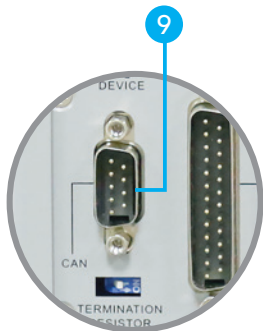
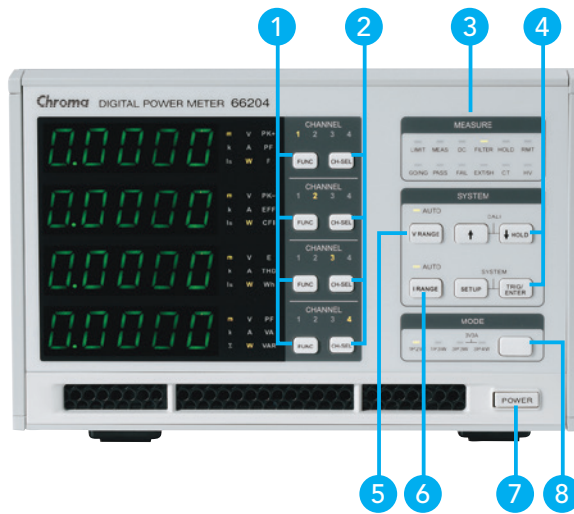

1. Parameter selection key
2. Channel selection key
3. System setting and function indicator
4. System configuration setting
5. Voltage range selection key
6. Current range selection key
7. Power ON/OFF switch
8. Wiring mode selection key
9. CAN interface
10. GPIB remote interface
11. USB remote interface
12. Control I/O signals
13. Voltage measurement inputs
14. AC input power
15. External shunt input
16. Current measurement inputs

## SPECIFICATIONS

Model	66203	66204
Channel	3	4
Parameters	V, Vpk, I, Ipk, Is, W, VA, VAR, PF, CFI, F, THD V, THD I, E	
<b>Voltage</b>		
Range	15V/30V/60V/150V/300V/600Vrms (CF=2), 6 range HV option up to 1800Vrms	
Accuracy	DC, 10Hz to 1kHz : 0.1% RD + 0.08% RNG 1kHz to 10kHz : (0.1+0.05 x kHz)% RD + 0.08% RNG	
Harmonics Accuracy	DC, 10Hz to 1kHz : 0.1% RD + 0.08% RNG 1kHz to 10kHz : (0.1+0.05 x kHz)% RD + 0.08% RNG	
Input Resistance	4MΩ	
<b>AC/DC Current</b>		
Range	5mA/20mA/50mA/200mA/500mA/2A/5A/20Arms (CF=4)	
Accuracy	DC, 10Hz to 1kHz : 0.1% RD + 0.1% RNG 1kHz to 10kHz : (0.1+0.05 x kHz)% RD + 0.1% RNG	
Harmonics Accuracy	10Hz to 1kHz : 0.1% RD + 0.1% RNG 1kHz to 10kHz : (0.1+0.05 x kHz)% RD + 0.1% RNG	
DC Current Accuracy	0.1% RD + 0.1% RNG	
<b>Power</b>		
Range	75mW ~ 12kW (48 ranges)	
Accuracy	47Hz to 63Hz : 0.1% RD + 0.1% RNG 1KHz to 10KHz : (0.1+0.1 x kHz)% RD + 0.18% RNG	
Power Factor accuracy	0.001+(15ppm/PF) x Hz	
<b>Frequency</b>		
Range	DC, 10Hz ~ 10kHz	
Accuracy	0.06% RD	
Frequency Source	Voltage Source	
<b>Others</b>		
Display Resolution	5 Digits	
Display Update Rate	0.25 sec / 0.5 sec / 1 sec / 2 sec	
Input Voltage	100~240V ± 10%, 50/60Hz	
Interface	GPIB + USB or CAN + USB	
Operation Temperature	0°C ~ 40°C	
Storage	-40°C ~ 85°C	
Safety & EMC	CE (include EMC & LVD)	
Dimension (H x W x D)	133 x 212 x 420 mm / 5.25 x 8.25 x 16.3 inch	
Weight	7.5 kg / 16.5 lbs	8.5 kg / 18.7 lbs

\* The specifications are valid only after the power meter is turned on more than one hour in a thermally stable environment.

## ORDERING INFORMATION

66203 : Digital Power Meter (3 CH with GPIB & USB interfaces)  
 66203 : Digital Power Meter (3 CH with CAN & USB interfaces)  
 66204 : Digital Power Meter (4 CH with GPIB & USB interfaces)  
 66204 : Digital Power Meter (4 CH with CAN & USB interfaces)  
 A662008 : Power Efficiency Test Softpanel  
 A662009 : Softpanel for 66200 Series  
 A662010 : Rack Mount Kit for 1 unit  
 A662012 : 1200V HV option kit  
 A662013 : External CT 50Arms  
 A662014 : External CT 100Arms  
 A662015 : Voltage and current measurement cables for Model 66204  
 A662016 : Voltage and current measurement cables for Model 66203  
 A662017 : Ultra High Precision DCCT 60A

A662018 : Ultra High Precision DCCT 200A  
 A662023 : 1800V HV option kit  
 A662024 : DCCT Power Adapter for single channel  
 A662025 : DCCT Power Adapter for multiple channel  
 B662002 : Rack Mount Kit  
 B662004 : 1200A AC Current Clamp  
 B662005 : Alligator Clips  
 L11-002987 : Ultra High Precision DCCT 400A peak  
 L11-002986 : Ultra High Precision DCCT 600A peak  
 L11-002985 : Ultra High Precision DCCT 1000A peak



A662024



A662025



**Ihr Ansprechpartner /  
Your Partner:**

**dataTec AG**  
 E-Mail: [info@datatec.eu](mailto:info@datatec.eu)  
 >>> [www.datatec.eu](http://www.datatec.eu)

Mess- und Prüftechnik. Die Experten.