

Fiber & Coax Distribution Amplifier

DA-36

Users Manual

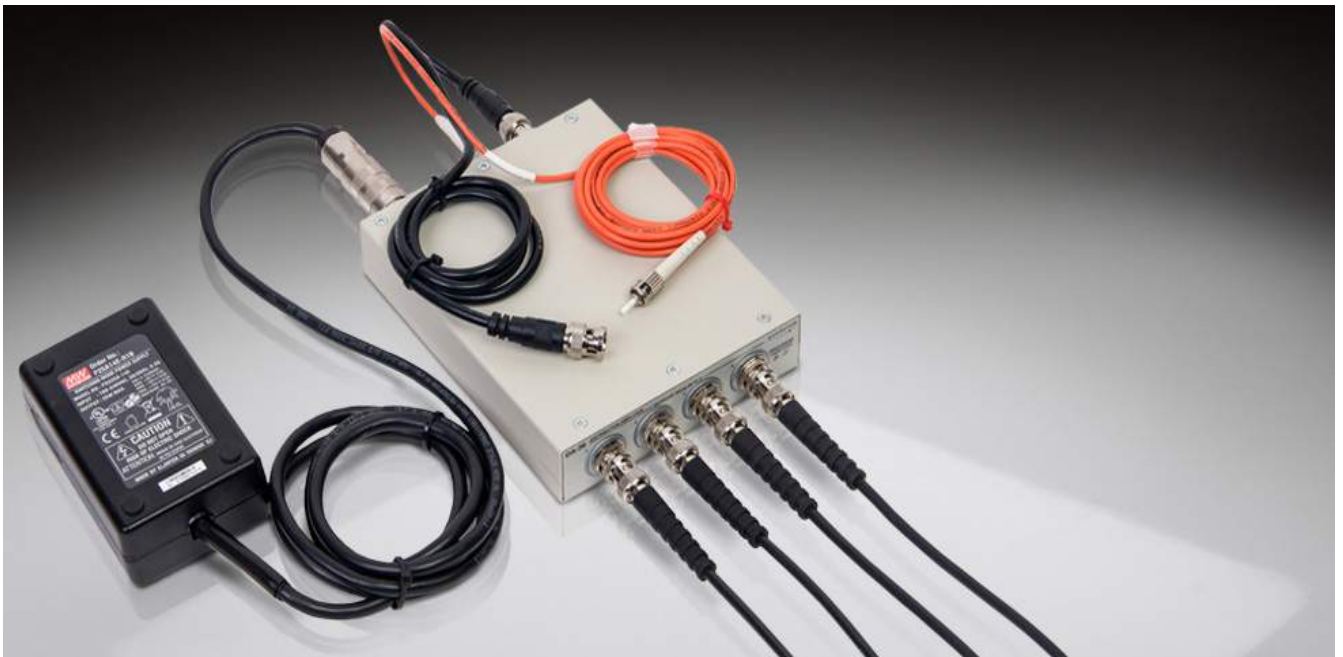

Technical Manual 90-20-DA-36 AK1.doc

Distributed by:

Sie haben Fragen oder wünschen eine Beratung? Angebotsanfrage unter **07121 / 51 50 50** oder über info@datatec.de

dataTec

About this manual

About the contents of this manual

The information in this document may be changed at any time without notice.

Table of Contents

About the contents of this manual	i	BNC-ports	8
Table of Contents	i	Configuration.	10
Version and revision history.	1	Power on.	10
Revision history for product:	1	LED-status.	11
Revision history for this document.	1	Sales and Service office	12
Safety Precautions	2	Disclaimer	13
If in doubt about safety	2	CE - mark	13
Functional	3		
Fiber optic distribution.	3		
Universal distribution amplifier.	3		
Easy operation.	4		
LED indicators.	4		
Grounding	4		
Technical specifications	5		
Fiber optic	5		
Electrical	5		
Power Supply.	5		
Physical size	5		
Environmental conditions	5		
Product DA-36 consists of:	6		
Serial number.	7		
Front Panel/Output Panel.	7		
Back Panel/Input Panel.	7		
Fiber Optic Port.	8		
Functional earth/ground.	8		

Version and revision history.

Revision history for product:

Revision 0.

Valid for serial number: *FS-02555 - (2004-06-03)*.

Revision history for this document.

Revision AK0.

2004-05-10, AnNy, document created.

Revision AK1.

2017-05-17, AnNy, text corrected.

Document properties.

Last saved: 2017-05-17

Filename: Technical Manual 90-20-DA-36 AK1.doc

Author.

Created by Anders Nyström.

Last saved by Ewa Bartłomiejczyk

Safety

Read this page carefully before you install and use the product. This product has been designed and tested according to safety Class 1 requirements of EN61010-1 and CSA 22.2 No.1010.1, and has been supplied in a safe condition. The user of this product must have the required knowledge of it. This knowledge can be gained by thoroughly studying this manual. This product is designed to be used by trained personnel only. Removing the cover for repair, maintenance, and adjustment of the product must be done by qualified personnel who are aware of the hazards involved.

Safety Precautions

To ensure the correct and safe operation of this product, it is essential that you follow generally accepted safety procedures in addition to the safety precautions specified in this manual.

Do not exceed maximum power, voltage and current ratings for inputs and outputs.



SAFETY

Fig. 2-1 Do not overlook the safety instructions!

If in doubt about safety

Whenever you suspect that it is unsafe to use the product, you must make it inoperative by doing the following:

- Disconnecting the line cord
- Clearly marking the product to prevent its further operation
- Informing your Pendulum representative.

For example, the product is likely to be unsafe if it is visibly damaged.

General description

Functional

The DA-36, Fiber & Coax Distribution Amplifier is intended to extend distance and galvanic isolate distribution of 10MHz reference frequency.

Fiber optic distribution.

In coaxial distribution nets, there is always a risk for unwanted ground loops and other types of EMI. Also distances are limited to a few meters depending on environment and the quality of the coax cables used. By converting the galvanic 10MHz signal to a fiber optic signal, ground loops are avoided and the distance can be extended up to more than 1km.

Universal distribution amplifier.

The DA-36 includes all functions in one unit.

- ❑ Coax input.
- ❑ Fiber optic input.
- ❑ 4 Coax outputs.
- ❑ Fiber optic output.

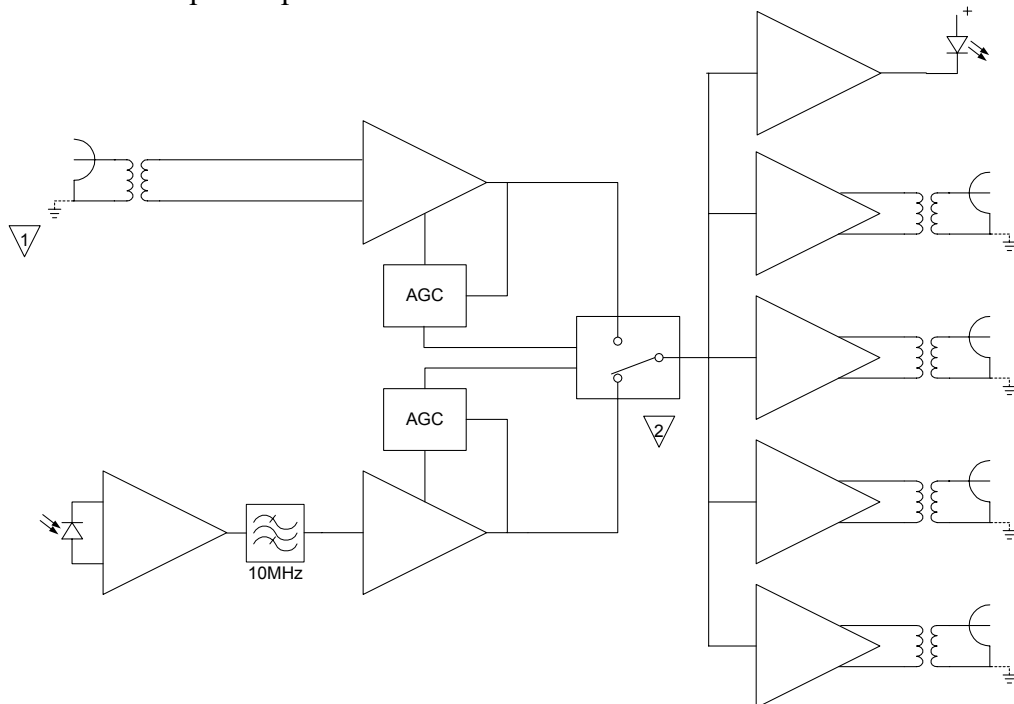

This enables the DA-36 to be used in any distribution situations. Coax to fiber conversion.

Fiber to coax conversion.

Coax to coax amplification and splitting.

Fiber to fiber amplification.

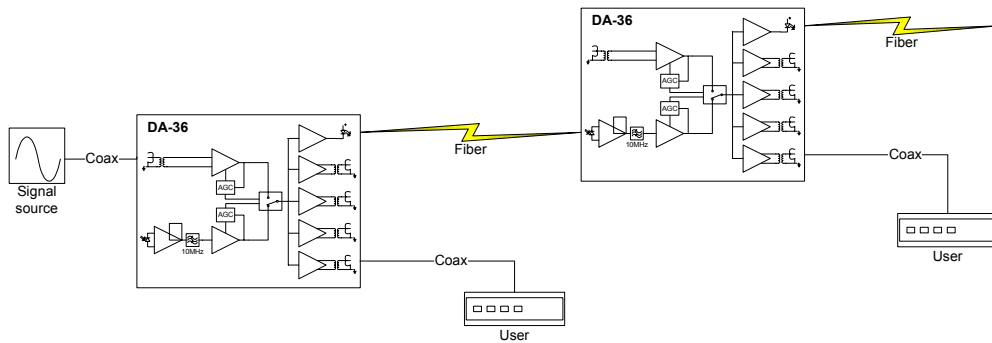

Easy operation.

There are no front panel controls.

Both coax input and fiber input has Automatic Gain Control, AGC.

If the input signal is outside the AGC's limits, the signal is too low or too high, the signal for that input is blocked.

If both inputs have a signal within AGC limits, the signal from the fiber input is used.



At the output panel, there are 2 LED's – INPUT STATUS .

They are marked – FIBER- and – COAX - .

They can both individually take the state of red or green.

Green indicates that the input has detected a signal within the AGC limits – Signal good.

Red indicates that the input signal is outside the AGC-limits, as when there is no signal attached. Red also indicates that the signal for this input is blocked.

If both LED's are green, the coax input signal is internally blocked and the fiber input signal is switched to the outputs, both fiber and coax outputs.

If both LED's are turned off , there is no power supplied to the DA-36.

Grounding

As ground loops are the cause of most problems in coaxial networks, all coaxial ports, both input and outputs are individually configurable to be galvanic isolated or connected to case/chassis ground.

The case also has a chassis ground screw.

Remember that ground connections shall be low impedance also at high frequencies, a bad ground connection can introduce unwanted ground loops, and degradation of signal quality.

Short distances and large conductor areas are essential.

Technical specifications

Fiber optic

Wavelength	820nm
Fiber optical connector	ST
Fiber type	Multimode fiber, 62.5/125 μ m or 50/125 μ m
Maximum optical attenuation Typical distance	8dB (including all connectors, splices and fiber). 2km

Electrical

Coax Input

Connector	BNC coax connector
Impedance	50 Ohm nominal
Amplitude	0.2V _{rms} – 2V _{rms} (sine).
RF power	max 0.25W
DC current	max 30mA

Coax Output

Connectors	4 x BNC coax connector
Impedance	50 Ohm nominal
Amplitude	1V _{rms} (sine)
Period-to-period Jitter	< (50ps + optical jitter). Optical jitter is due to optical attenuation and depends on quality and length of fiber used. Optical jitter is 0ps for 1m and typically <100ps for 1km.

Power Supply.

Input voltage range	90 - 264VAC, 47 – 63Hz, 0.8A
AC connector	Euro, 2 pin.
Power consumption	<25W.

Physical size

The unit is intended to be used stand alone or mounted on a wall.	30 mm (rubber feet or wallmount brackets excluded).
Height	125 mm
Width	190 mm (from BNC input to BNC output, no cables connected).
Depth	0,7 kg
Weight	Xkg, including power supply.
Shipping weight	

Environmental conditions

Operating temperature	0 - 50°C
Storage temperature	-40 ...+70°C
Safety	CSA22.2 No. 231, EN61010-1 + A1 (1992), + A2 (1995), Cat II, Pollution degree 2
EMC	EN61326/A1 (1998)

Unpacking.

Check that all packing material has no damage. If damages are discovered on packing material, contact your shipping company, before unpacking.

The delivered product consists of several parts. Check that all part are present according to list, and have no damage.

Product DA-36 consists of:

	Quantity	Part number	Description
1	1	DA-36	Fiber & Coax Distribution Amplifier <i>(Part number includes all parts in this list).</i>
2	2	60-00-5437	Wall Mounting Bracket
3	6	50-65-1673	Screw, MFX-H M3x5 FZB
4	4t	50-65-5030	Rubber feet
5	5	50-65-5101	Isolating washers for BNC
6	1	60-00-5538	Power supply.
7	1	50-65-5128	Power cord
8	1	90-20-DA-36	This manual



DA-36, *(Part number includes all parts in list above).*

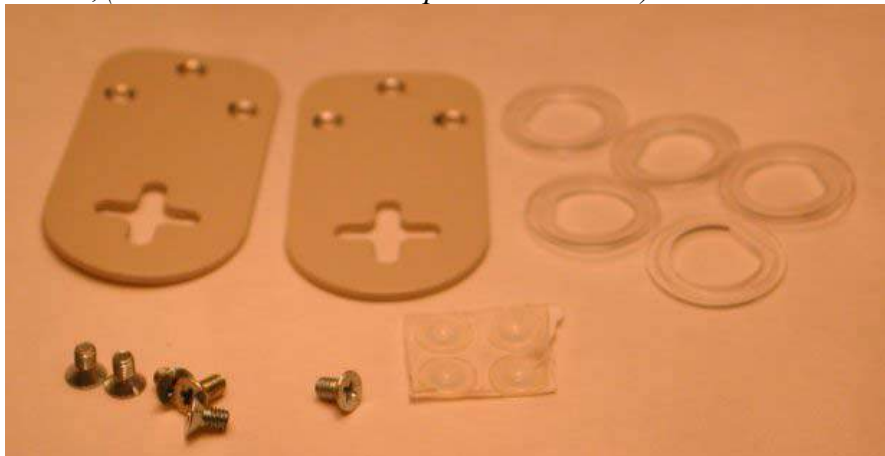

Wall mounting kit, rubber feet and isolation washers.

Installation.

Serial number.

The products serial number is the best way for Pendulum Instruments to identify the product.

If the serial number is not noted on your delivery notes, please add the serial number to your own product documentation. This will be useful at future contact with Fiberdata System.

Front Panel/Output Panel.

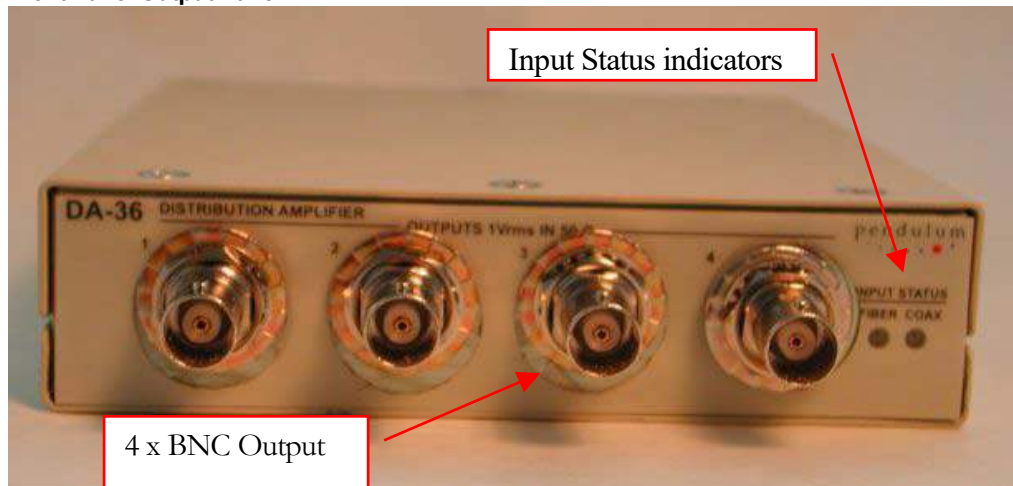

Back Panel/Input Panel.

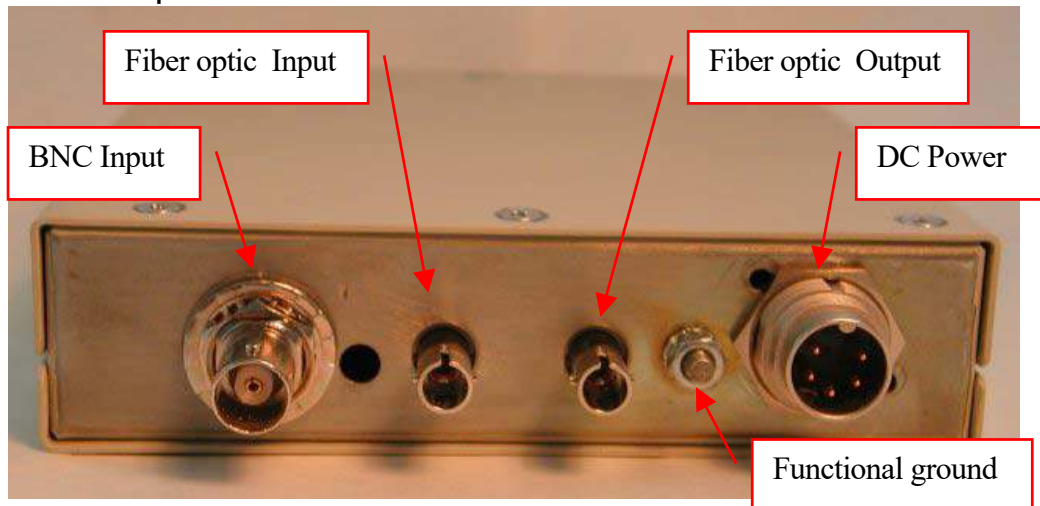

Fiber Optic Port.

The fiber optic connectors are of ST type.

The quality of the signal very much depends on the attenuation of the fiber optic cable and splices.

For example the optical jitter is due to optical attenuation and depends on quality and length of fiber used. Optical jitter is 0ps for 1m and typically <100ps for 1km.

It is therefore essential to keep the attenuation low. Patch cables and splices should be kept as few as possible. Connectors shall be kept clean. Use a dry clean cotton cloth, or similar, for polishing . If alcohol or any other solution is used for cleaning, always polish with a dry cloth, to make sure that there is no residue left.

If a small amount of jitter can be accepted the AGC can control up to 8dB in link attenuation, which equals approximately 2km fiber.

Two or more DA-36 can be cascaded to extend link length.

Make sure that the source fiber optic transmitter, marked Tx, is connected to the remote units fiber optic receiver, marked Rx.

Functional earth/ground.



Connect to the functional ground screw if DA-36 chassis needs to be referenced to ground.

This connection must be low impedance also at RF-frequencies.

BNC-ports

All BNC-ports are referenced to DA-36 chassis at delivery. They can individually be configured to be isolated.

This is done by:

1. Loosen nut at BNC – 14mm nut.



2. Add one of the isolation washers delivered with the DA-36.

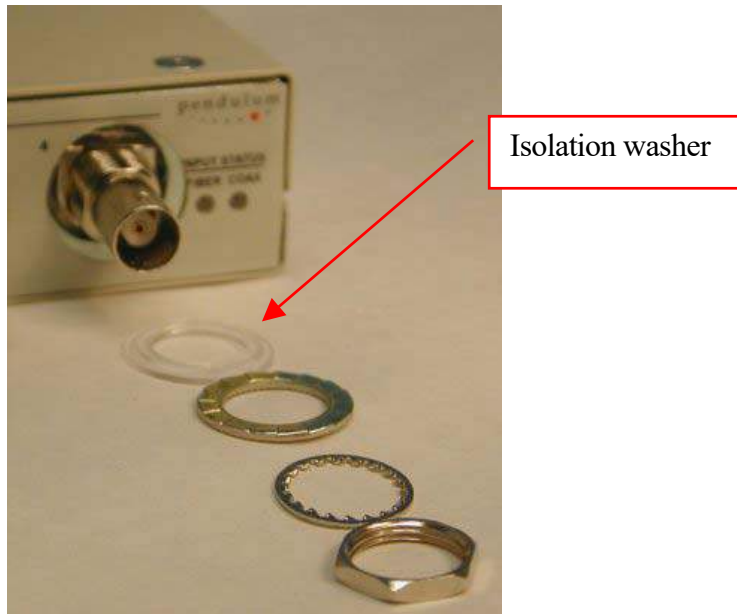

The isolation washer shall be added closest to the panel.

3. Reassemble the washers and the nut in reverse order.



Use gentle force while tightening the nut.

Configuration

Configuration.

There are no parameters to be configured or set.

The DA-36 can be used in many distribution situations.

Coax to fiber conversion.

Fiber to coax conversion.

Coax to coax amplification and splitting.

Fiber to fiber amplification.

The DA-36 can be cascaded to form large tree-structures of distributed reference signal nets.

Start and usage.

Power on.

The DC-cable from the power supply shall be connected to DA-36.

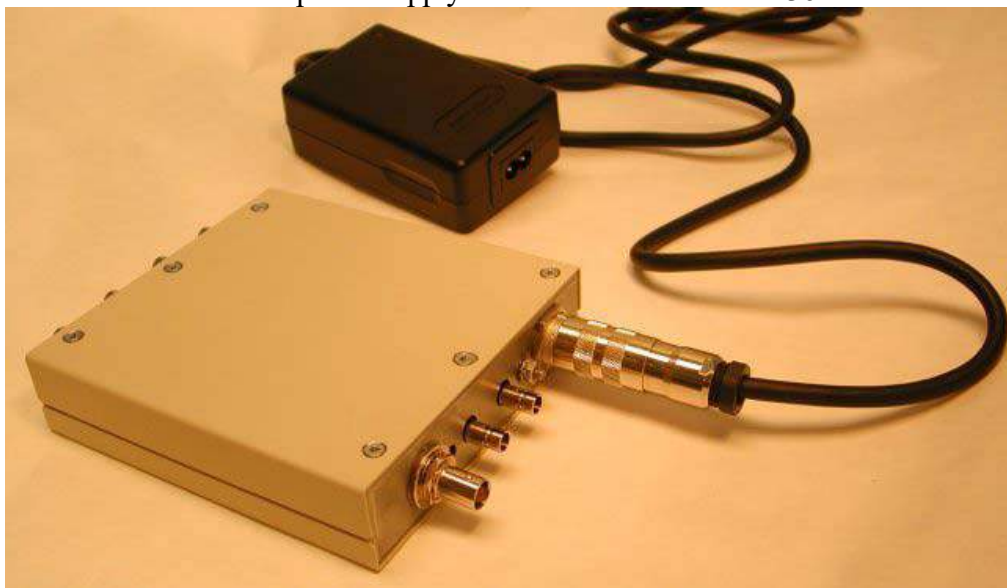

Connect power supply AC-cord to mains.

Allow DA-36 to warm-up for some minutes. Wait to connect fiber- or coax-signal to input until both Input Status indicators are red.

LED-status.

There are two LED-indicators at the output panel – INPUT



They are marked – FIBER- and – COAX - .

They can both individually take the state of red or green.

Green indicates that the input has detected a signal within the AGC limits – Signal good.

Red indicates that the input signal is outside the AGC-limits, as when there is no signal attached. Red also indicates that the signal for this input is blocked.

If both LED's are green, the coax input signal is internally blocked and the fiber input signal is switched to both fiber and coax outputs.

If both LED's are turned off/black , there is no power supplied to the DA-36.

Note that the Input Status indications do not evaluate the quality of the input signals, only the amplitude.

Service

Sales and Service office

For additional product information, customer support and service, please contact Pendulum Instruments at the following address:

Altaria Services Sp. z.o.o

ul. Lotnicza 37

80-298 Banino

Poland

Visiting address:

as above

Delivery address:

as above

Phone: +48 (58) 681 89 01

Fax: +48 (58)684 86 49

Email: service@pendulum.se

Internet: www.pendulum.se

Warranty

The Warranty Statement is part of the folder *Important Information* that is included with the shipment.

Declaration of Conformity

The complete text with formal statements concerning product identification, manufacturer and standards used for type testing is available on request.