

6517B Electrometer/High Resistance Meter

DATASHEET



The Keithley 6517B Electrometer/High Resistance Meter is the worldwide research laboratory standard for sensitive measurements. With over 60 years of low level measurement expertise, Keithley electrometers provide reliable measurements of current levels down to 10 aA (10×10^{-18} A), charge levels down to 1 fC, and the highest resistance measurements available up to $10^{18} \Omega$. The 6517B is also capable of measuring the largest voltage range—up to 200 V—with an input impedance exceeding 200 T Ω . All this performance is built into an instrument that operates as simply as a digital multimeter.

Exceptional Performance Specifications

The 6517B has incorporated Keithley's decades of expertise in low level measurement technology into an innovative, low current input amplifier with an input bias current of <3 fA, just 0.75 fA p-p noise, and <20 μ V burden voltage on the lowest current ranges. The voltage circuit input impedance is greater than 200 T Ω for near-ideal circuit loading. These specifications ensure the accuracy and sensitivity needed for accurate low current and high impedance voltage, resistance, and charge measurements in areas of research such as physics, optics, nanotechnology, and materials science. A built-in ± 1 kV voltage source with sweep capability simplifies performing leakage, breakdown, and resistance testing, as well as volume (Ω -cm) and surface resistivity (Ω /square) measurements on insulating materials.

Key Features

- Measures resistances up to $10^{18} \Omega$
- 10 aA (10×10^{-18} A) current measurement resolution
- Complete hardware–software solution for ASTM D257 high resistivity measurements with the 6517B, 8009 Resistivity Test Fixture, and the KickStart High Resistivity Application
- <3 fA input bias current
- 6½-digit high accuracy measurement mode
- <20 μ V burden voltage on the lowest current ranges
- Voltage measurements up to 200 V with >200 T Ω input impedance
- Built-in ± 1000 V voltage source
- Unique alternating polarity voltage sourcing and measurement method for high resistance measurements
- Built-in test sequences for four different device characterization tests, surface and volume resistivity, surface insulation resistance, and voltage sweeping
- Optional plug-in scanner cards for testing up to ten devices or material samples with one test setup
- GPIB and RS-232 interfaces

Wide Measurement Ranges

The 6517B offers autoranging over the full span of ranges on current, resistance, voltage, and charge measurements. The 6517B combines the following measurement capabilities:

- Ultra-sensitive ammeter with current measurement from 10 aA to 20 mA
- Highest impedance voltmeter with voltage measurement from 1 μ V to 200 V
- Ultra-high range ohmmeter with resistance measurement from 1 Ω to $10^{18} \Omega$
- Sensitive coulombmeter with charge measurement from 1 fC to 2 μ C

Ihr Ansprechpartner /
Your Partner:

dataTec AG
E-Mail: info@datatec.eu
datatec.eu

dataTec

KEITHLEY
A Tektronix Company

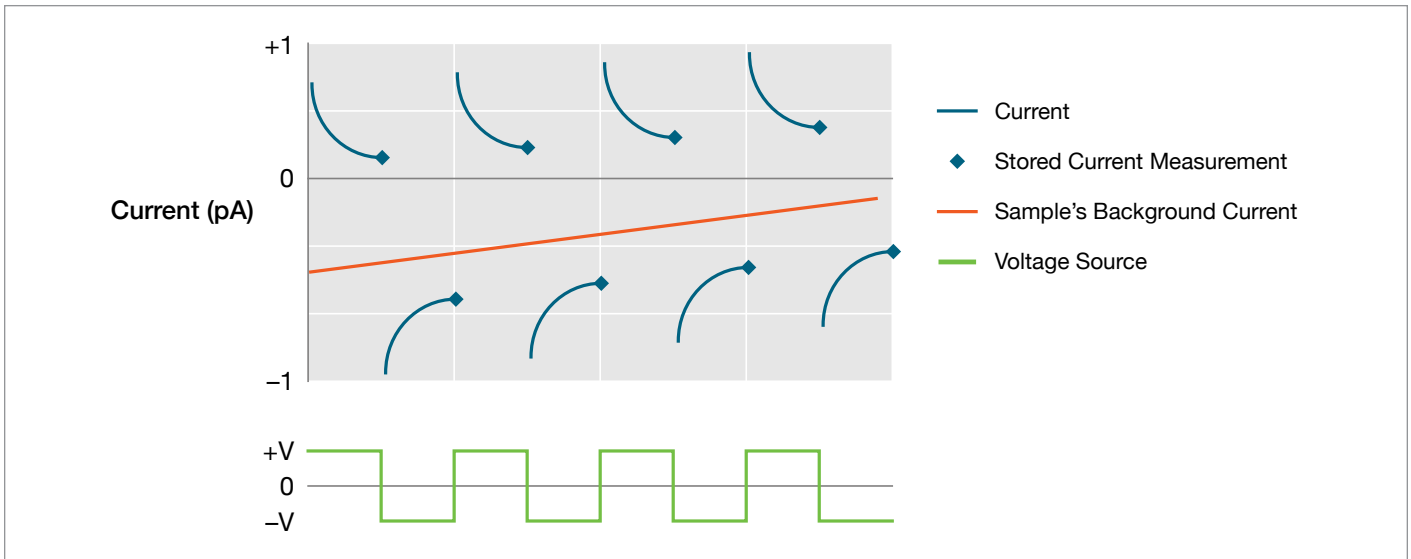

The alternating voltage source polarity method eliminates the effects of background currents in materials for making repeatable, accurate high resistance and resistivity measurements.

Improved High Resistivity Measurements

Many test applications require measuring high levels of resistivity (surface or volume) of materials. The conventional method of making these measurements is to apply a sufficiently large voltage to a sample, measure the current that flows through the sample, then calculate the resistance using Ohm's Law ($R=V/I$). While high resistance materials and devices produce very small currents that are difficult to measure accurately, Keithley electrometers and picoammeters are used successfully for such measurements.

Even with high quality instrumentation, inherent background currents in the material can make these measurements difficult to perform accurately. Insulating materials, polymers, and plastics typically exhibit background currents due to piezoelectric effects, capacitive elements charged by static electricity, and polarization effects. These background currents are often equal to or greater than the current stimulated by the applied voltage. In these cases, the result is often unstable, providing inaccurate resistance or resistivity readings or even erroneous negative values. Keithley's 6517B is designed to solve these problems and provides

consistent, repeatable, and accurate measurements for a wide variety of materials and components, especially when used in combination with the 8009 Resistivity Test Fixture.

Alternating Polarity Method for High Resistivity Measurements

The 6517B uses the Alternating Polarity Method, which virtually eliminates the effect of any background currents in the sample. First and second order drifts of the background currents are also canceled out. The Alternating Polarity Method applies a voltage of positive polarity, then the current is measured after a specified delay (Measure Time). Next, the polarity is reversed and the current measured again, using the same delay. This process is repeated continuously, and the resistance is calculated based on a weighted average of the four most recent current measurements. This method typically produces a highly repeatable, accurate measurement of resistance (or resistivity) by the seventh reversal on most materials (i.e., by discarding the first three readings). For example, a 1mm-thick sample of 10^{14} Ω -cm material can be measured with 0.3% repeatability in the 8009 Resistivity Test Fixture, provided the background current changes less than 200 fA over a 15-second period.

Built-In Source Enhances Accuracy of High Resistance Measurements

The 6517B offers a number of features and capabilities that help ensure the accuracy of high resistance measurement applications. For example, the built-in voltage source simplifies determining the relationship between an insulator's resistivity and the level of source voltage used. It is well-suited for capacitor leakage and insulation resistance measurements, tests of the surface insulation resistance of printed circuit boards, voltage coefficient testing of resistors, and diode leakage characterization.

Complete High Resistivity Measurement Solution

Perform high resistivity measurements using test methods defined by the standard, ASTM D-257, "DC Resistance or Conductance of Insulating Materials", with the following package:

- KICKSTARTFL-HRMA2 High Resistivity Application for the KickStart Instrument Software Control environment
- 6517B Electrometer
- 8009 Resistivity Test Fixture

The KickStart High Resistivity Application controls the electrometer and the test fixture to perform all the measurements needed to make ASTM- D-257 standard resistivity measurements. Test materials at

voltages up to 1000 V. Determine resistivity up to 10^{18} Ω -cm. Analyze step response plots of current vs time to determine how long to wait for a measurement to settle on the material-under-test. Analyze a plot of multiple readings to ensure that settled and consistent measurements are being taken. The KickStart High Resistance Application uses the alternating polarity technique to eliminate inherent background currents for the most accurate resistivity measurements. Also use the application to observe resistivity dependency on temperature and relative humidity using the optional thermocouple and relative humidity probes.

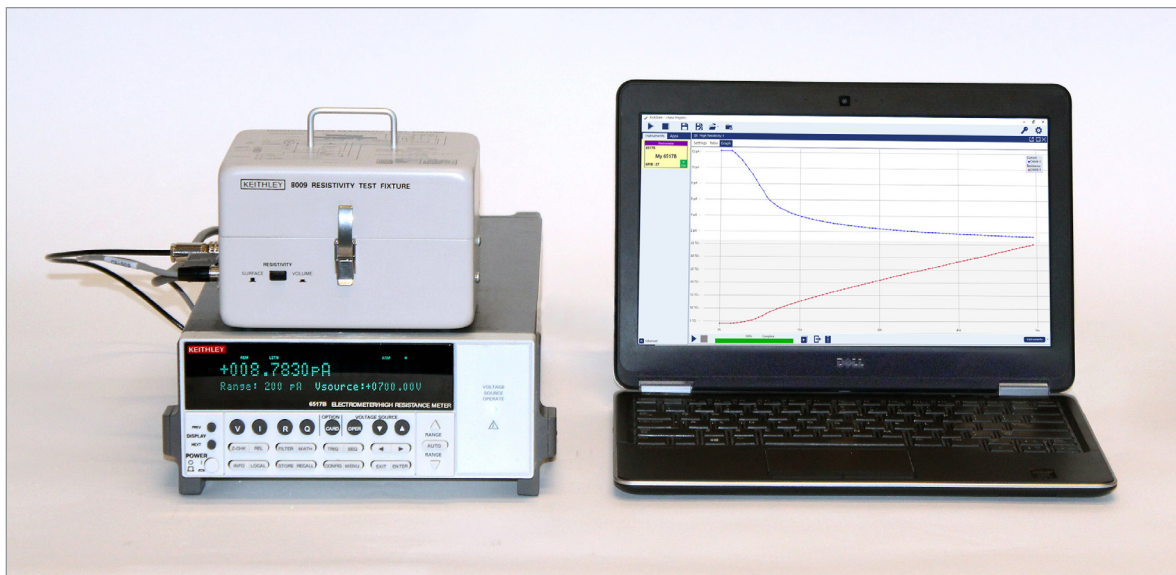

ASTM-D257-compliant High Resistivity Test System with the 6517B Electrometer, 8009 Resistivity Test Fixture, and the KickStart High Resistivity Application.

Measurement Type: Volume Resistivity

Measurement Mode: Step Response

Use ASTM D257 Procedure:

Test Voltage: 500 V

Test Time: 60 s

Current Range: Auto

NPLC: 1

Measure Temperature:

Measure Humidity:

Use 8009 Test Fixture Geometries:

Electrode Area: 20.97 cm²

Material Thickness: 1 mm

Meter Connect:

Discharge Device:

Sources 0V for 4x Test Time

Auto Discharge:

Volume Resistivity: 19.4 PΩ-cm

KickStart High Resistivity step response plot

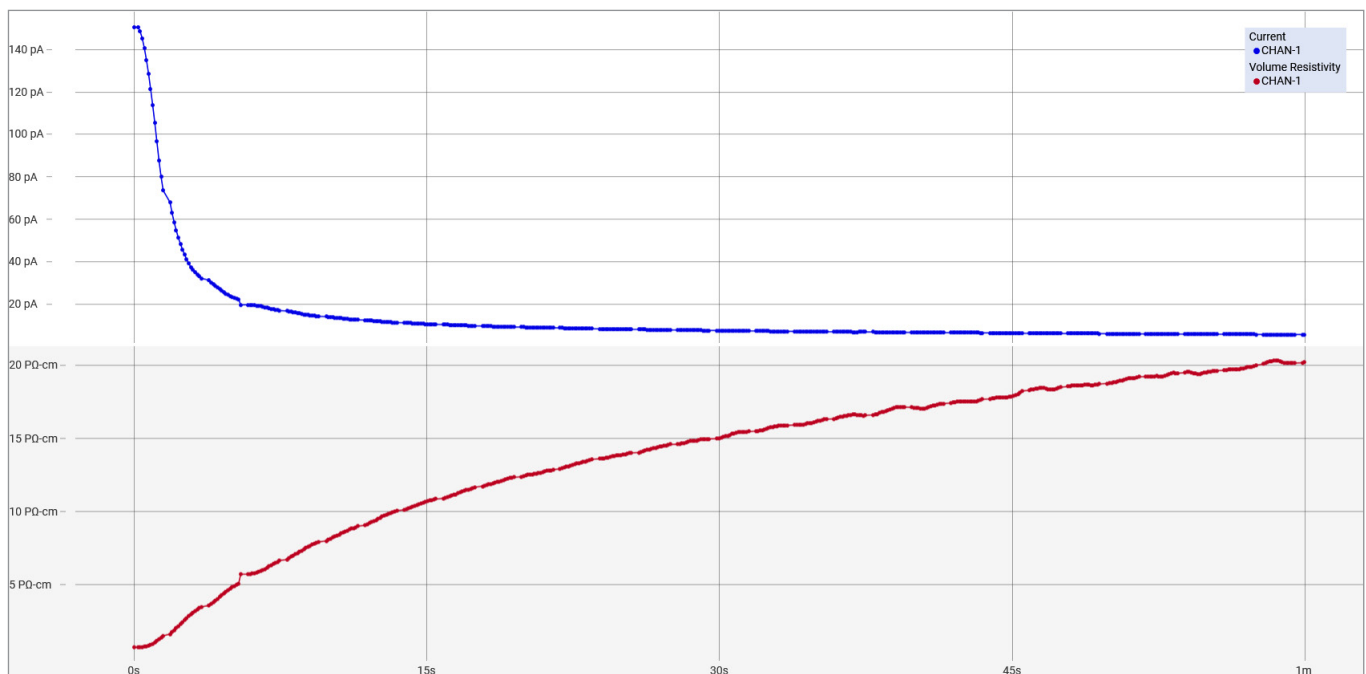

KickStart High Resistivity resistivity plot

Internal Test Sequences Expand and Simplify Applications

The 6517B has a number of internal test sequences that assists in easily setting up and performing a number of tests. Device characterization sequences include diode leakage current measurement, capacitor leakage current measurement, cable insulation resistance measurement, and resistor voltage coefficient measurement. Resistivity and resistance tests include volume resistivity, surface resistivity, and surface insulation resistance testing. Parameters can be characterized as a function of voltage with the square wave and staircase test sequences.

In addition to its built-in tests, the 6517B excels in low current, high impedance voltage, resistance, and charge measurements in areas of research such as physics, optics, and materials science. The electrometer's extremely low voltage burden makes it particularly valuable for use in solar cell characterization applications and its built-in voltage source and low current sensitivity make it an excellent solution for high resistance measurements of nanomaterials such as polymer-based nanowires, other nanomaterials, ceramics, dielectric films, and biomaterials.

With its highly responsive measurements and DMM-like operation, the 6517B performs well in quality control, design engineering, and production test applications involving leakage current, breakdown, and resistance testing. Volume and surface resistivity measurements on non-conductive materials are particularly enhanced by the 6517B's voltage reversal method. The 6517B is also excellent for electrochemistry applications such as high impedance, ion-selective electrodes and pH measurements, conductivity cells, and potentiometry.

Typical Applications

- Nanomaterial characterization
- Polymer electrical characterization
- Beam measurements
- Dosimetry
- Device leakage current measurements
- Insulation resistance measurements
- Optoelectronic detector characterization
- Volume and surface resistivity

Accessories Extend Measurement Capabilities

A variety of optional accessories can be used to extend the 6517B applications and enhance its performance.

The 8009 Resistivity Test Fixture is a guarded test fixture for measuring volume and surface resistivities of sample materials. It has stainless-steel electrodes built to ASTM D257 standards. The fixture's electrode dimensions are pre-programmed into the 6517B, so there's no need to calculate those values then enter them manually. This accessory is designed to protect you from contact with potentially hazardous voltages —opening the lid of the test fixture automatically turns off the 6517B's voltage source.



8009 Resistivity Test Fixture is compliant with American Society for Testing and Materials (ASTM) Standard D257 Standard Test Methods for DC Resistance or Conductance of Insulating Materials. The 8009 combined with the 6517B provides a complete system for making high quality, safe resistivity measurements. The 8009 comes with the 6517B-ILC-3 Safety Interlock Cable, the 7078-TRX-3 Triax-Triax Cable, and the 8607 1 kV Source Voltage Banana Jack Cable Set.

6521 and 6522 Low Current, 10-Channel Scanner Cards

Two optional 10-channel plug-in scanner cards are available to extend the measurement performance of the 6517B Electrometer/High Resistance Meter. The cards install directly into the option slot in the back panel of the 6517B. The cards are also compatible with the 6517A and 6517.

The 6521 Low Current Scanner Card is a 10-channel multiplexer, designed for switching low currents in multipoint testing applications or when the test configuration must be changed. Offset current on each channel is <math><1\text{ pA}</math> and high isolation is maintained between each channel (>10¹⁵ Ω). The 6521 maintains the current path even when the channel is deselected, making it a true current switch. BNC input connectors help provide shielding for sensitive measurements and make the card compatible with low noise coaxial cables. The 6521 is well suited for

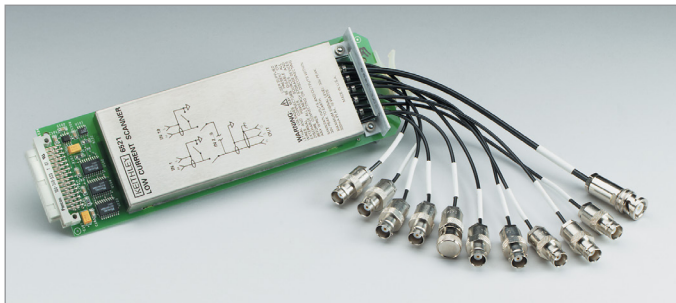

6521 Low Current Scanner Card.

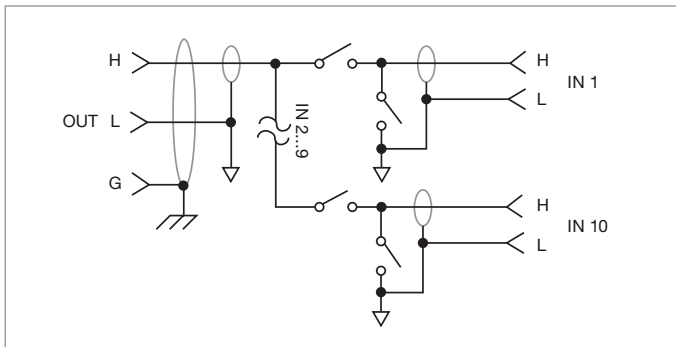

6521 schematic.

automating reverse leakage tests on semiconductor junctions or gate leakage tests on FETs.

The 6522 Voltage/Low Current Scanner Card can provide up to ten channels of low-level current, high impedance voltage, high resistance, or charge switching. Although it's similar to the 6521 in many ways, the 6522's input connectors are 3-lug triax. The card can be software configured for high impedance voltage switching of up to 200 V. Triaxial connectors make it possible to float the card 500 V above ground and drive guard to 200 V.

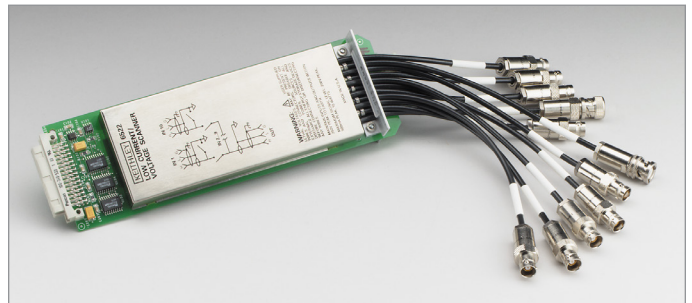

6522 Voltage/Low Current Scanner Card.

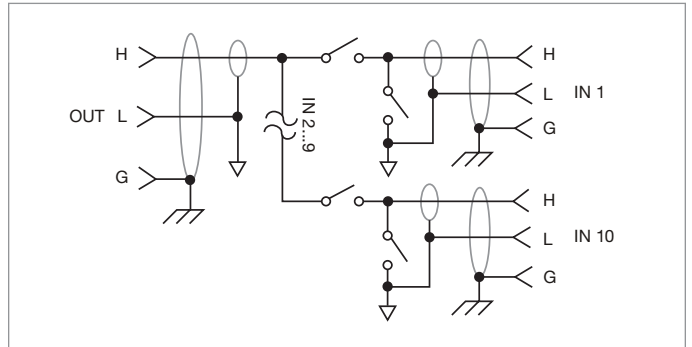

6522 schematic.

6521 and 6522 Specifications

Channels Per Card	10.
Functions	6521: Amps. 6522: Volts, Amps.
Contact Configuration	Single pole, "break-before-make" for signal HI input. Signal LO is common for all 10 channels and output. When a channel is off, signal HI is connected to signal LO. 6522: 6517B can also configure channels as voltage switches.
Connector Type	6521: Inputs: BNC. Outputs: Triaxial. 6522: Inputs: Triaxial. Outputs: Triaxial.
Signal Level	6521: 30 V, 500 mA, 10 VA (resistive load). 6522: 200 V, 500 mA, 10 VA (resistive load).
Contact Life	>10 ⁶ closures at maximum signal level; >10 ⁷ closures at low signal levels.
Contact Resistance	<1 Ω.
Contact Potential	<200 μV.
Offset Current	<1 pA (<30 fA typical at 23°C, <60% RH).
Actuation Time	2 ms.
Common Mode Voltage	6521: <30 V peak. 6522: <300 V peak.
Channel Isolation (6522)	>10 ¹³ Ω, <0.3 pF.
Input Isolation (6522)	>10 ¹⁰ Ω, <125 pF (Input HI to Input LO).
Environment	Operating: 0°C to 50°C up to 35°C at 70% R.H. Storage: -25°C to 65°C.

Specifications

Volts

Range	6½-Digit Resolution	Accuracy (1 Year) ¹ 18°–28°C ±(% + offset)	Temperature Coefficient 0°–18°C & 28°–50°C ±(% + offset)/°C
2 V	1 µV	0.025 + 40 µV	0.003 + 20 µV
20 V	10 µV	0.025 + 300 µV	0.002 + 100 µV
200 V	100 µV	0.06 + 3 mV	0.002 + 1 mV

NMRR 2 V and 20 V ranges: >60 dB. 200 V range: >55 dB. 50 Hz or 60 Hz².

CMRR >120 dB at DC, 50 Hz or 60 Hz.

Input Impedance >200 TΩ in parallel with 20 pF, <2 pF guarded (1 MΩ with zero check on).

Small Signal Bandwidth at Preamp Output

Typically 100 kHz (–3 dB).

Notes

- When properly zeroed, 6½-digit, 1 PLC (power line cycle), median filter on, digital filter = 10 readings.
- Line sync on.

Amps

Range	6½-Digit Resolution	Accuracy (1 Year) ¹ 18°–28°C ±(% reading + offset)	Temperature Coefficient 0°–18°C & 28°–50°C ±(% reading + offset)/°C
20 pA	10 aA ²	1 + 3 fA	0.1 + 500 aA
200 pA	100 aA ²	1 + 5 fA	0.1 + 1 fA
2 nA	1 fA	0.2 + 300 fA	0.1 + 20 fA
20 nA	10 fA	0.2 + 500 fA	0.03 + 100 fA
200 nA	100 fA	0.2 + 5 pA	0.03 + 1 pA
2 µA	1 pA	0.1 + 100 pA	0.005 + 20 pA
20 µA	10 pA	0.1 + 500 pA	0.005 + 100 pA
200 µA	100 pA	0.1 + 5 nA	0.005 + 1 nA
2 mA	1 nA	0.1 + 100 nA	0.008 + 20 nA
20 mA	10 nA	0.1 + 500 nA	0.008 + 100 nA

Input Bias Current <3 fA at T_{CAL}. Temperature coefficient = 0.5 fA/°C, 20 pA range.

Input Bias Current Noise <750 aA p-p (capped input), 0.1 Hz to 10 Hz bandwidth, damping on. Digital filter = 40 readings, 20 pA range.

Input Voltage Burden at T_{CAL} ±1°C <20 µV on 20 pA, 2 nA, 20 nA, 2 µA, and 20 µA ranges.
<100 µV on 200 pA, 200 nA, and 200 µA ranges.
<2 mV on 2 mA range. <5 mV on 20 mA range.

Temperature Coefficient of Input Voltage Burden

<10 µV/°C on pA, nA, and µA ranges.

Preamp Settling Time (to 10% of final value), Typical

0.5 s (damping off) 2.0 s (damping on) on pA ranges. 15 ms on nA ranges damping off, 1 ms on µA ranges damping off. 500 µs on mA ranges damping off.

NMRR >60 dB on all ranges at 50 Hz or 60 Hz³.

Notes

- When properly zeroed, 6½-digit, 1 PLC (power line cycle), median filter on, digital filter = 10 readings.
- aA = 10⁻¹⁸ A, fA = 10⁻¹⁶ A.
- Line sync on.

Ohms (Normal Method)

Range	6½-Digit Resolution	Accuracy (1 Year) ¹ (10–100% Range) 18°–28°C ±(% reading + offset)	Temperature Coefficient (10–100% Range) 0°–18°C & 28°–50°C ±(% reading + offset)	Auto V Source	Amps Range
2 MΩ	1 Ω	0.125 + 10 Ω	0.01 + 10 Ω	40 V	200 μA
20 MΩ	10 Ω	0.125 + 100 Ω	0.01 + 100 Ω	40 V	20 μA
200 MΩ	100 Ω	0.15 + 1 kΩ	0.015 + 1 kΩ	40 V	2 μA
2 GΩ	1 kΩ	0.225 + 10 kΩ	0.035 + 10 kΩ	40 V	200 nA
20 GΩ	10 kΩ	0.225 + 100 kΩ	0.035 + 100 kΩ	40 V	20 nA
200 GΩ	100 kΩ	0.35 + 1 MΩ	0.110 + 1 MΩ	40 V	2 nA
2 TΩ	1 MΩ	0.35 + 10 MΩ	0.110 + 10 MΩ	400 V	2 nA
20 TΩ	10 MΩ	1.025 + 100 MΩ	0.105 + 100 MΩ	400 V	200 pA
200 TΩ	100 MΩ	1.15 + 1 GΩ	0.125 + 1 GΩ	400 V	20 pA

Notes

1. Specifications are for auto V-source ohms, when properly zeroed, 6½-digit, 1 PLC, median filter on, digital filter = 10 readings. If user selectable voltage is required, use manual mode. Manual mode displays resistance (up to 10¹⁸ Ω) calculated from measured current. Accuracy is equal to accuracy of V-source plus accuracy of selected Amps range.

Preamp Settling Time

Add voltage source settling time to preamp settling time in Amps specification. Ranges over 20 GΩ require additional settling based on the characteristics of the load.

Ohms (Alternating Polarity Method)

The alternating polarity sequence compensates for the background (offset) currents of the material or device under test. Maximum tolerable offset up to full scale of the current range used.

Using Keithley 8009 fixture**Repeatability**

$\Delta I_{BG} \times R / V_{ALT} + 0.1\% (1\sigma)$ (instrument temperature constant $\pm 1^\circ\text{C}$).

Accuracy

$(V_{SRC}Err + I_{MEAS}Err \times R) / V_{ALT}$

where: ΔI_{BG} is a measured, typical background current noise from the sample and fixture.

V_{ALT} is the alternating polarity voltage used.

$V_{SRC}Err$ is the accuracy (in volts) of the voltage source using V_{ALT} as the setting.

$I_{MEAS}Err$ is the accuracy (in amps) of the ammeter using V_{ALT}/R as the reading.

Voltage Source

Range	5½-Digit Resolution	Accuracy (1 Year) 18°–28°C ±(% setting + offset)	Temperature Coefficient 0°–18°C & 28°–50°C ±(% setting+offset)/°C
100 V	5 mV	0.15 + 10 mV	0.005 + 1 mV
1000 V	50 mV	0.15 + 100 mV	0.005 + 10 mV

Maximum Output Current

100 V Range: ± 10 mA, hardware short circuit protection at < 14 mA.
1000 V Range: ± 1 mA, hardware short circuit protection at < 1.4 mA.

Settling Time

100 V Range: < 8 ms to rated accuracy.
1000 V Range: < 50 ms to rated accuracy.

Noise (typical)

100V Range: < 2.6 mV rms.
1000V Range: < 2.9 mV rms.

Coulombs

Range	6½-Digit Resolution	Accuracy (1 Year) ^{1,2} 18°–28°C, ±(% reading + offset)	Temperature Coefficient 0°–18°C & 28°–50°C ±(% reading + offset)/°C
2 nC	1 fC	0.6 + 50 fC	0.04 + 30 fC
20 nC	10 fC	0.6 + 500 fC	0.04 + 100 fC
200 nC	100 fC	0.4 + 5 pC	0.04 + 1 pC
2 µC	1 pC	0.4 + 50 pC	0.04 + 10 pC

Notes

1. Specifications apply immediately after charge acquisition. Add

$$\left(4 \text{ fA} + \frac{10 \text{ pC}}{\text{RC}}\right) T_A$$

where T_A = time in seconds between the coulombs zero and measurement and Q_{AV} = average charge measured over T_A and $\text{RC} = 300,000$ typical.

2. When properly zeroed, 6½-digit, 1 PLC (power line cycle), median filter on, digital filter = 10 readings.

Input Bias Current <4 fA at T_{CAL} ; temperature coefficient = 0.5 fA/°C, 2 nC range.

Temperature (Thermocouple)

Thermocouple Type	Range	Accuracy (1 Year) ¹ , 18°–28°C ±(% reading + °C)
K	-25°C to 150°C	±(0.3 + 1.5°C)

Humidity

Range	Accuracy (1 Year) ² 18°–28°C, ±(% reading + % RH)
0–100%	±(0.3 + 0.5)

Notes

1. Excluding probe errors, $T_{\text{CAL}} \pm 5^\circ\text{C}$, 1 PLC integration time.

2. Humidity probe accuracy must be added. This is $\pm 3\%$ RH for 6517-RH, up to 65°C probe environment, not to exceed 85°C.

IEEE-488 Bus Implementation

Implementation	SCPI (IEEE-488.2, SCPI-1999.0).
Trigger to Reading Done	150 ms typical, with external trigger.
RS-232 Implementation	Supports: SCPI 1991.0. Baud Rates: 300, 600, 1200, 2400, 4800, 9600, 19.2k, 38.4k, 57.6k, and 115.2k.
Flow Control	None, Xon/Xoff.
Connector	DB-9 TXD/RXD/GND.

General Characteristics

Display	6½-digit vacuum fluorescent multiline.
Overrange Indication	Display reads "OVERFLOW" for readings >105% of range. The display reads "OUT OF LIMIT" for excessive overrange conditions.
Ranging	Automatic or manual.
Conversion Time	Selectable 0.01 PLC to 10 PLC.
Maximum Input	250 V peak, DC to 60 Hz sine wave; 10 s per minute maximum on mA ranges.
Maximum Common Mode Voltage (DC to 60 Hz sine wave)	Electrometer, 500 V peak; V Source, 750 V peak.
Isolation (Meter COMMON to chassis)	>10 ¹⁰ Ω, <500 pF.
Input Connector	Three lug triaxial on rear panel.
2 V Analog Output	2 V for full range input. Non-inverting in Volts mode, inverting when measuring Amps, Ohms, or Coulombs. Output impedance 10 kΩ.
Preamp Output	Provides a guard output for Volts measurements. Can be used as an inverting output or with external feedback in Amps and Coulombs modes.
External Trigger	TTL compatible External Trigger and Electrometer Complete.
Guard	Switchable voltage guard available.
Digital I/O and Trigger Line	Available, see manual for usage.
EMC	Conforms to European Union Directive 89/336/EEC, EN 61326-1.
Safety	Conforms to European Union Directive 73/23/EEC, EN 61010-1.
Reading Storage	50,000.
Reading Rates	To Internal Buffer: 425 readings/second ¹ . To IEEE-488 Bus: 400 readings/second ^{1,2} . Bus Transfer: 3300 readings/second ² . 1. 0.01PLC, digital filters off, front panel off, temperature + RH off, Line Sync off. 2. Binary transfer mode.
Digital Filter	Median and averaging.
Environment	Operating: 0°–50°C; relative humidity 70% non-condensing, up to 35°C. Storage: –25° to +65°C.
Altitude	Maximum 2000 meters above sea level per EN 61010-1.
Warm-Up	1 hour to rated accuracy (see manual for recommended procedure).
Power	User selectable 100, 120, 220, 240 VAC ±10%; 50/60 Hz, 100 VA max.
Physical	Case Dimensions: 90 mm high × 214 mm wide × 369 mm deep (3½ in. × 8½ in. × 14½ in.). Working Dimensions: From front of case to rear including power cord and IEEE-488 connector: 394 mm (15.5 inches). Net Weight: 5.4 kg (11.8 lbs.). Shipping Weight: 6.9 kg (15.11 lbs.).

Ordering Information

6517B	Electrometer/High Resistance Meter
-------	------------------------------------

Supplied Accessories

237-ALG-2	Low Noise Triax Cable, 3-slot Triax to Alligator Clips, 2 m (6.6 ft)
-----------	----------------------------------------------------------------------

8607	Safety High Voltage Dual Test Leads
------	-------------------------------------

6517-TP	Thermocouple Bead Probe
---------	-------------------------

CS-1305	Interlock Connector
---------	---------------------

Available Software

KICKSTARTFL-HRMA2	KickStart High Resistivity Application Software; Perpetual Floating License Option*
-------------------	-------------------------------------------------------------------------------------

KICKSTARTFL-HRMA2-UP	KickStart High Resistivity Application Software; Annual Maintenance License for extending the Perpetual Floating License Option*
----------------------	----------------------------------------------------------------------------------------------------------------------------------

KICKSTARTFL-HRMA2-AN	KickStart High Resistivity Application Software; 1 year Time-Based Floating License Option**
----------------------	----------------------------------------------------------------------------------------------

* Perpetual Licenses: The software can be used indefinitely; license does not expire but updates/support only available for the first 12 months. Support can be extended by purchasing a maintenance license. If a perpetual license goes out of support, all features will be frozen to the last released version before the support expired. The software will continue to work, but you cannot get any updates newer than the support expiration date.

- Maintenance Licenses – Apply to perpetual licenses only. Maintenance license is an extension license that extends the period of support of an original perpetual license for 12 months.

** Time-based Licenses: The software can be used throughout the term of the license only. Software updates and support through the term of the license are included. When the Time-Based license expires, all features will no longer work, but a new Time-Based license may be purchased.

Available Accessories

Test Fixture

8009	Resistivity Test Fixture
------	--------------------------

Scanner Cards

6521	Low Current Scanner Card
------	--------------------------

6522	Voltage/Low Current Scanner Card
------	----------------------------------

Cables

6517B-ILC-3	Interlock Cable
-------------	-----------------

7007-1	Shielded IEEE-488 Cable, 1 m (3.2 ft)
--------	---------------------------------------

7078-TRX-x	Low Noise Triax Cable, 3-Slot Triax Connectors, x=3: 0.9 m (3 ft), x=10: 3 m (10 ft), x=20: 6 m (20 ft)
------------	---------------------------------------------------------------------------------------------------------

8501-1	Trigger Link Cable, 1 m (3.3 ft)
--------	----------------------------------

8503	Trigger Link Cable to 2 male BNCs, 1 m (3.3 ft)
------	-------------------------------------------------

Other

CS-1305	Interlock Connector
---------	---------------------

Adapters

237-BNC-TRX	Male BNC to 3-Lug Female Triax Adapter
-------------	----------------------------------------

237-TRX-T	3-Slot Male Triax to Dual 3-Lug Female Triax Tee Adapter
-----------	----------------------------------------------------------

237-TRX-TBC	3-Lug Female Triax Bulkhead Connector (1.1 kV rated)
-------------	------------------------------------------------------

7078-TRX-BNC	3-Slot Male Triax to BNC Adapter
--------------	----------------------------------

7078-TRX-GND	3-Slot Male Triax to BNC Adapter, guard removed
--------------	-------------------------------------------------

7078-TRX-TBC	3-Lug Female Triax Bulkhead Connector with Cap
--------------	------------------------------------------------

Rack Mount Kits

4288-1	Single Fixed Rack Mounting Kit
4288-2	Dual Fixed Rack Mounting Kit

 GPIB Interfaces

KPCI-488LPA	IEEE-488 Interface/Controller for the PCI Bus
KUSB-488B	IEEE-488 USB-to-GPIB Interface Adapter

Service Options

6517B-EW	1 Year KeithleyCare Gold Extended Warranty Plan
6517B-3Y-EW-STD	3 Year KeithleyCare Gold Extended Warranty Plan
6517B-5Y-EW-STD	5 Year KeithleyCare Gold Extended Warranty Plan
C/6517B-3Y-STD	KeithleyCare 3-Calibration, 3-Year Standard Calibration Plan
C/6517B-3Y-DATA	KeithleyCare 3-Calibration, 3-Year Calibration Plan with Data
C/6517B-3Y-17025	KeithleyCare 3-Calibration, 3-Year ISO 17025 Calibration Plan
C/6517B-5Y-STD	KeithleyCare 5-Calibration, 5-Year Standard Calibration Plan
C/6517B-5Y-DATA	KeithleyCare 5-Calibration, 5-Year Calibration Plan with Data
C/6517B-5Y-17025	KeithleyCare 5-Calibration, 5-Year ISO 17025 Calibration Plan

Warranty Information

Warranty Summary	This section summarizes the warranties of the 6517B. For complete warranty information, refer to the Tektronix warranty page at https://www.tek.com/service/warranties/warranty-2 . Any portion of the product that is not manufactured by Keithley is not covered by this warranty and Keithley will have no duty to enforce any other manufacturer's warranties.
Hardware Warranty	Keithley Instruments, Inc. warrants the Keithley manufactured portion of the hardware for a period of one year from defects in materials or workmanship; provided that such defect has not been caused by use of the Keithley hardware which is not in accordance with the hardware instructions. The warranty does not apply upon any modification of Keithley hardware made by the customer or operation of the hardware outside the environmental specifications.
Software Warranty	Keithley warrants for the Keithley produced portion of the software or firmware will conform in all material respects with the published specifications for a period of ninety (90) days; provided the software is used on the product for which it is intended in accordance with the software instructions. Keithley does not warrant that operation of the software will be uninterrupted or error-free, or that the software will be adequate for the customer's intended application. The warranty does not apply upon any modification of the software made by the customer.

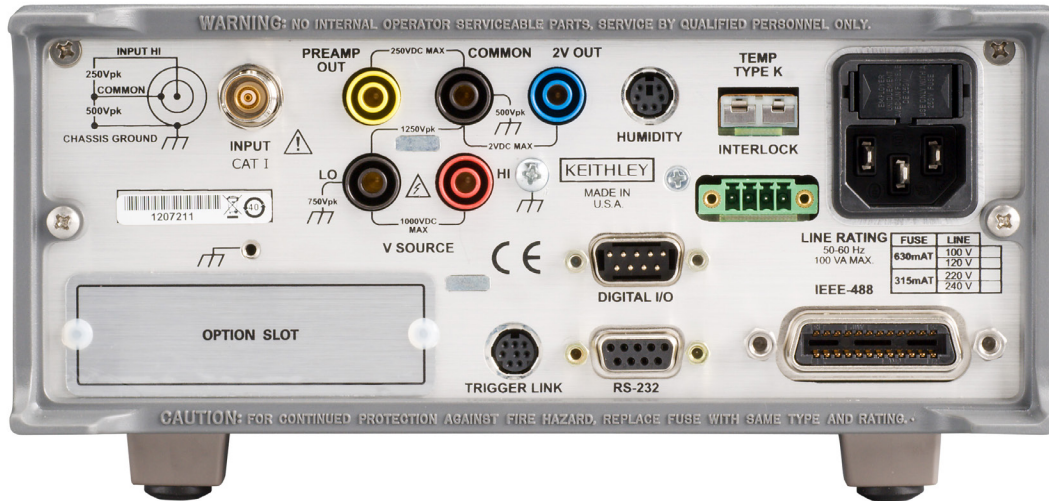

6517B rear panel.

Contact Information:

Australia 1 800 709 465
Austria* 00800 2255 4835
Balkans, Israel, South Africa and other ISE Countries +41 52 675 3777
Belgium* 00800 2255 4835
Brazil +55 (11) 3530-8901
Canada 1 800 833 9200
Central East Europe / Baltics +41 52 675 3777
Central Europe / Greece +41 52 675 3777
Denmark +45 80 88 1401
Finland +41 52 675 3777
France* 00800 2255 4835
Germany* 00800 2255 4835
Hong Kong 400 820 5835
India 000 800 650 1835
Indonesia 007 803 601 5249
Italy 00800 2255 4835
Japan 81(3) 6714 3086
Luxembourg +41 52 675 3777
Malaysia 1 800 22 55835
Mexico, Central/South America and Caribbean 52 (55) 88 69 35 25
Middle East, Asia, and North Africa +41 52 675 3777
The Netherlands* 00800 2255 4835
New Zealand 0800 800 238
Norway 800 16098
People's Republic of China 400 820 5835
Philippines 1 800 1601 0077
Poland +41 52 675 3777
Portugal 80 08 12370
Republic of Korea +82 2 565 1455
Russia / CIS +7 (495) 6647564
Singapore 800 6011 473
South Africa +41 52 675 3777
Spain* 00800 2255 4835
Sweden* 00800 2255 4835
Switzerland* 00800 2255 4835
Taiwan 886 (2) 2656 6688
Thailand 1 800 011 931
United Kingdom / Ireland* 00800 2255 4835
USA 1 800 833 9200
Vietnam 12060128

* European toll-free number. If not accessible, call: +41 52 675 3777

Rev. 02.2022



**Ihr Ansprechpartner /
Your Partner:**

dataTec AG
E-Mail: info@datatec.eu
datatec.eu

Mess- und Prüftechnik. Die Experten.



Find more valuable resources at TEK.COM

Copyright © Tektronix. All rights reserved. Tektronix products are covered by U.S. and foreign patents, issued and pending. Information in this publication supersedes that in all previously published material. Specification and price change privileges reserved. TEKTRONIX and TEK are registered trademarks of Tektronix, Inc. All other trade names referenced are the service marks, trademarks or registered trademarks of their respective companies.

092024 SBG 1KW-60280-1

