



Probing Solutions.
Made in Germany.

EN



Mess- und Prüftechnik. Die Experten.

**Ihr Ansprechpartner /
Your Partner:**

dataTec AG

E-Mail: info@datatec.eu

>>> www.datatec.eu



FireFly[®]

**High Voltage Optically-Isolated Probe
with Universal BNC Interface**

>1.5 GHz, >180dB CMRR

Preliminary

Instruction Manual



Manufacturer

PMK Mess- und Kommunikationstechnik GmbH
Königsteiner Str. 98
65812 Bad Soden, Germany

Tel: +49 (0) 6196 999 5000

Internet: www.pmk.de
E-Mail: sales@pmk.de

Warranty

PMK warrants this product for normal use and operation within specifications for a period of one year from date of shipment and will repair or replace any defective product, which was not damaged by negligence, misuse, improper installation, accident or unauthorized repair or modification by the buyer. This warranty is applicable only to defects due to material or workmanship. PMK disclaim any other implied warranties of merchantability or fitness for a particular purpose. PMK will not be liable for any indirect, special, incidental, or consequential damages (including damages for loss of profits, loss of business, loss of use or data, interruption of business and the like), even if PMK has been advised of the possibility of such damages arising from any defect or error in this manual or product.

Table of Contents	
Manufacturer	2
Warranty	2
Compliance Information	4
IEC Pollution Degrees	5
IEC Safety Symbols	5
Safety and Handling Information	6
Safety and Handling Information (Continued)	7
Lithium-Ion 18650 Battery Charging and Storage Information	7
Clearance Requirements	8
About FireFly®	9
Factory Calibration	9
Specifications	10
Electrical Specifications ¹	10
Electrical Specifications (Continued)	11
Environmental Specifications	12
Physical Specifications	12
Dimensions	12
Typical Common Mode Rejection Ratio (CMRR)	13
Typical Maximum Differential Input Voltage (CW)	13
Typical Frequency Response	14
Typical Pulse Response	14
Typical Differential Input Impedance	15
User Interface	15
Interface Box Controls & Indicators	15
Probe Status Indicator	16
Probe Head Battery Level Indicators	16
Probe Head Power ON/OFF Button	16
Auto-Zero Button	16
Remote Interface	17
Getting Started	17
Cable Selection	17
Probe Setup	17
Connection to the Test Points (Circuit-Under-Test)	18
Making the Measurement	19
Scope of Delivery	19
Ordering Information	20

Compliance Information

The FireFly® probing system complies with the following relevant union harmonization legislation, safety and environmental standards. Only professionals and qualified personnel should use this product. Serious injury or death may occur as result of incorrect usage of this product.

Probe

- IEC/EN 61010-1:2010 - Safety Requirements for Electrical Equipment for Measurement, Control and Laboratory Use, Part 1: General Requirements
- IEC/EN 60825-1 - Safety of Laser Products Part 1: Equipment Classification and Requirements -Edition 3 (2014)
- US 21CFR Part 1010 - Performance Standards for Electronic Products: General
- US 21CFR Part 1040 - Performance Standards for Light- Emitting Products
- Laser Certification: Class 1 Laser Product

This product complies with 21 CFR 1040.10 and 1040.11 except for deviations pursuant to Laser Notice No. 50, dated June 24, 2007.

CAUTION. Use of controls or adjustments for performance of procedures other than those specified herein may result in hazardous exposure.

Battery

- EU model: CE conform. *More information follow soon.*
- US model: UL conform. *More information follow soon.*
- Asian model: PSE conform. *More information follow soon.*

IEC Pollution Degrees

Definitions and Examples:

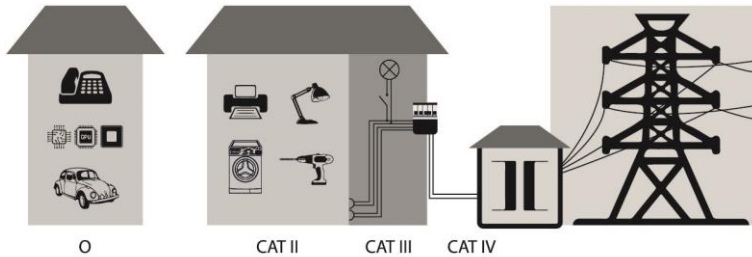

Overview of measurement categories according to IEC 61010-01

O = No Measurement Category (Other circuits that are not directly connected to mains)

- Pollution Degree 1** No POLLUTION or only dry, non conductive POLLUTION. NOTE: The POLLUTION has no influence.
- Pollution Degree 2** Only- non conductive POLLUTION. Occasionally, however, a temporary conductivity caused by condensation must be accepted.
- Pollution Degree 3** Conductive POLLUTION occurs or dry, non-conductive POLLUTION occurs which becomes conductive due to condensation which is to be expected.

IEC Safety Symbols

The following symbols may appear on the product or in this instruction manual:



Caution, risk of danger. Refer to manual.



Caution, risk of electric shock.



Earth (ground) TERMINAL.

Safety and Handling Information

The probe head, tip cables and accessories are NOT for hand-held use. The overall safety of any measurement setup incorporating this probe is the responsibility of the user.



The probe head is optically isolated and galvanically isolated from the measuring system and earth ground.



To avoid personal injury and to prevent fire or damage to this product or products connected to it, review and comply with the following safety precautions. Be aware that if you use this probe assembly in a manner not specified the protection this product provides may be impaired. Only qualified personnel should use this probe assembly.



Beware of High Voltages.

Observe probe and probe accessory ratings. Do not apply any electrical potential to the probe input, which exceeds the maximum ratings of the probe head, tip cables or the accessories connected to it. In a combination, the lower rating / measurement category applies to both the probe and accessories connected to it. Make sure to comply with the voltage versus frequency derating curve.

Do not connect the probe head/tip cable to an energized circuit to avoid the risk of shock. Always de-energize the circuit-under-test before installing or removing the probe head or tip cable from the circuit-under-test. The plastic case of the probe head and insulating sleeve on the tip cable do not supply adequate isolation



Keep away from hazardous live circuits.

Avoid open circuitry. Do not touch connections or components when power is present. Maintain safe clearance from the Probe Head and Tip Cable while connected to the energized circuit

Avoid unnecessary stress.

The small electrical components of the probe are sensitive to shock and impact. Avoid any unnecessary stress to the probe like throwing, falling and strong vibrations.

The FireFly® fiber cable between the probe head and the interface box contains multiple optical fibers. Avoid tight radius bends, crushing, crimping, twisting, or otherwise stressing of the fiber cable. Do not crush, crimp, twist, pull, jerk or sharply bend the fiber-optic cable. Avoid making loops in the fiber-optic cable smaller than 12.7cm (5in).

Avoid over-bending the Probe Head's Tip Cables; do not exceed the minimum bend radius of 5cm (2in).

Keep products clean and dry.

Remove all connections of the probe before cleaning. Keep the fiber cable clean and free from contaminants in order to maintain the 60kV common mode voltage rating.

Inspect the fiber cable for dirt, contaminants or damage before each use and clean using a dry, lint-free cloth. If dirt remains, use a soft cloth or swab dampened with a 75% isopropyl alcohol solution and rinse with deionized water. A swab is useful for cleaning narrow spaces, use only enough solution to dampen the swab or cloth. Do not use abrasive compounds on any part of the probe.

Do not use chemical cleaning agents; they may damage the probe. Avoid using chemicals that contain benzene, benzene, toluene, xylene, acetone, or similar solvents.

Continues on next page.

Safety and Handling Information (Continued)

Do not operate with suspected failures.

Refer to qualified service personnel.

Do not operate in wet or damp conditions.

Condensation may occur if a unit is moved from a cold to a warm environment.

Do not operate the product in an explosive atmosphere.



Connect and disconnect properly.

The circuit-under-test **MUST BE DE-ENERGIZED (TURNED OFF)** when handling, connecting & disconnecting the probe head, tip cables or accessories to the circuit.

Use ONLY non-conductive probe head & tip holders.

Use only PMK recommended 18650 batteries in the probe head.

Avoid applying an input signal without batteries in the probe head.

Use only the originally provided carry case to store or transport the probe not in use.

If the probe is no longer being used, and before the probe is placed back into the probe case, remove the battery from the probe head for storage.

Lithium-Ion 18650 Battery Charging and Storage Information

For optimal charging, the ambient temperature during charging should be $24\pm 2.5^{\circ}\text{C}$. Batteries should be stored in a dry, room temperature space. Avoid any situations that might subject the batteries to either extreme cold or heat. Between the range of -20°C to $+50^{\circ}\text{C}$ (-4°F to $+122^{\circ}\text{F}$) is sufficient but the most optimal storage temperature is somewhere around 77°F or 25°C .



Before handling the probe head to change the battery, make sure the circuit under test has been de-energized or has been disconnected from the circuit-under-test.

Use ONLY the PMK recommended 18650 batteries, in the probe head. If using a battery with a built in USB charge port, connect the appropriate USB cable and connect to a USB port on the oscilloscope, AC power adaptor or PC. Use only the PMK recommended charger.

Charging times will vary based on the battery and the charger used.



Observe battery safety: The FireFly® probe head is powered by a user-replaceable 18650 rechargeable Lithium-Ion battery.

To avoid personal injury or property damage due to electrical burst, smoke, fire or explosions, please operate the probe within the specified operating conditions.

Do not drop the probe or subject it to strong impacts.

Do not use the probe if it has been damaged in any way.

Clearance Requirements

The probing system can be used for very high common mode voltages. Observe all pre-cautions and information from the manual when using this product. See also the specifications and referring derating curves in this manual.



Maintain at least 1m (40in) safe clearance of the probe head, tip cable and tip cable accessories in all directions when connected to an energized circuit.

RF burn hazard zone around the probe head and tip cable



Maximum Safe Handling Limits
Common Mode Voltage (Probe Head to Earth Ground)

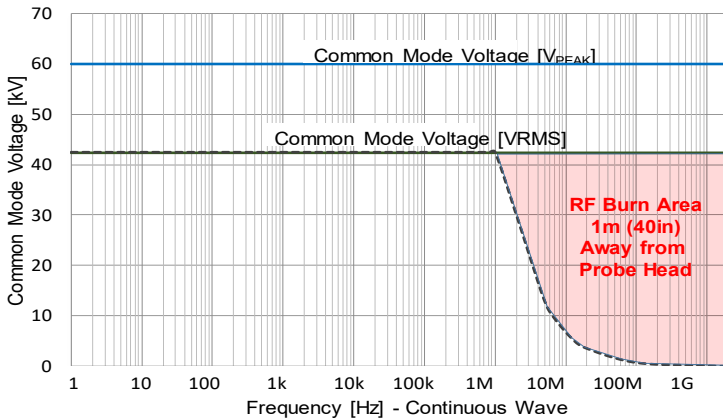

About FireFly®

The FireFly® high voltage optically isolated probe offers industry leading performance that combines the ability to accurately resolve high bandwidth, small differential signals in the presence of large common mode voltages with its ultra-high common mode rejection performance across its entire bandwidth. With >1.5GHz bandwidth, wide differential input range, unmatched common mode rejection ratio CMRR up to >180dB (1 billion to 1 rejection), and a 60kV common mode, FireFly® is the ideal measurement solution for both GaN and SiC device characterization and system level design development.

PMK's optically isolated interface and unique compact angled probe head design are the key attributes that set FireFly® apart from the other solutions in the market, providing very stable and accurate measurements over a wide temperature range and easy access to the measurement points in tight spaces.

The compact angled probe head design allows for shorter tip cables to be used, resulting in higher signal fidelity measurements and reduced stresses placed on the measurement test point. FireFly®'s wide selection of probe tip connections and accessories offer reliable, hands-free, high-fidelity connectivity to the measurement points. Using industry standard MMCX and square pins connections allow FireFly® to easily interface to test boards that have already been design with these test points. The FireFly® probe head is powered by an easy to change, rechargeable, industry standard 18650 battery that provides continuous operation for up to 30h at room temperature. FireFly® has a universal BNC output connector and is compatible with any oscilloscope with a 50Ω input impedance or 1MΩ input impedance and a 50Ω feed-through termination, allowing FireFly® to be used on any oscilloscope in the lab. For accurate deskew, each probe's unique propagation delay is measured and added to each probe label.

Coming soon: FireFly® series will have the capability to be controlled from either remote control or the controls located on the interface box. The „PMK Probe Control“ software provides the ability for the user to control the probe remotely via a computer, and provides the user with a graphical user interface. The software is free of charge, and included with PMK's 2ch and 4ch power supplies PS2 and PS3, which are required to power the probe. The PS2 and PS3 power supplies all have a USB interface and are available with optional LAN interface. The new AP-01, 1 channel battery pack power supply, provides > 8h of portable and isolated operation, which allows the user the flexibility of where the probe can be used. The AP-01 supplies power only to the probe with no software remote control.

Factory Calibration

Annual re-calibration is recommended. ISO17025 calibration upon delivery or as re-calibration will be possible on request.

Specifications

Read the Instruction Manual before first use, and keep it for future reference. A digital copy of the latest Instruction Manual revision can be downloaded at www.pmk.de

Specifications that are marked with * are guaranteed, others are typical. Do not exceed specifications. Allow the probe to warm up for 20 minutes. The probe head and tip cables are not for handheld use. The probe can be used without the probe tip. To achieve the most accurate measurement results, review the “Getting Started” section in the Instruction Manual. This probe comes with 1 year warranty.

Electrical Specifications¹

Observe adequate spacing between probe head components and earth ground. This product is not rated for CAT II, III or IV. Do not exceed the specifications. Use original PMK power supplies only.

FireFly®	Bandwidth * (-3dB)	Rise time * (10% - 90%)	Input Attenuation	Input Impedance ²
SMA Input	> 1.5 GHz	<280 ps	1X	200 kΩ 4.0 pF
FF-MMCX-1V	> 1.5 GHz	<280 ps	1X	50 Ω ³
FF-MMCX-10V	> 1.3 GHz	<280 ps	10X	2 MΩ 3.4 pF
FF-MMCX-25V	> 1.3 GHz	<280 ps	25X	4.9 MΩ 2.1 pF
FF-MMCX-50V	> 1.3 GHz	<280 ps	50X	10 MΩ 2 pF
FF-MMCX-250V	TBD	TBD	250X	TBD
FF-WSQ-500V	TBD	TBD	500X	TBD
FF-WSQ-1000V	TBD	TBD	1000X	TBD
FF-WSQ-2500V	TBD	TBD	2500X	TBD

Maximum Rated Input Voltages ⁴

Common Mode Voltage ⁵ (Maximum Voltage to Earth)	± 60 kV (DC + Peak AC)	
No Measurement Category	Linear Input Voltage Range (DC + Peak AC) ²	Maximum Non-Destruct Differential Input Voltage (DC + Peak AC) ²
SMA Input	± 1 V	5 V
FF-MMCX-1V	± 1 V	5 V
FF-MMCX-10V	±10 V	50 V
FF-MMCX-25V	± 25 V	100 V
FF-MMCX-50V	± 50 V	100 V
FF-MMCX-250V	± 250 V	TBD
FF-WSQ-500V	± 500 V	TBD
FF-WSQ-1000V	± 1000 V	TBD
FF-WSQ-2500V	± 2500 V	TBD
Pollution Degree	2	

See next page for more Electrical Specifications and footnotes.

Electrical Specifications (Continued)

Common Mode Rejection Ratio	DC	1 MHz	100 MHz	200 MHz	500 MHz	1 GHz
SMA Input	> 180 dB	165 dB	110 dB	100 dB	90 dB	90 dB
FF-MMCX-1V	> 180 dB	145 dB	95 dB	85 dB	90 dB	90 dB
FF-MMCX-10V	> 180 dB	145 dB	85 dB	82 dB	80 dB	65 dB
FF-MMCX-25V	> 180 dB	142 dB	78 dB	75 dB	76 dB	58 dB
FF-MMCX-50V	> 180 dB	135 dB	75 dB	70 dB	70 dB	50 dB
FF-MMCX-250V	> 180 dB	TBD	TBD	TBD	TBD	TBD
FF-WSQ-500V	> 180 dB	TBD	TBD	TBD	TBD	TBD
FF-WSQ-1000V	> 180 dB	TBD	TBD	TBD	TBD	TBD
FF-WSQ-2500V	> 180 dB	TBD	TBD	TBD	TBD	TBD
DC Gain Accuracy	< 2 % ± DC Offset voltage - preliminary					
Noise (input referred)	SMA Input (1X): < 2 mV rms <i>With tip cable: (SMA Input noise) · (Tip cable input attenuation)⁷ scales proportionally to tip attenuation</i>					
DC Offset Voltage (input referred)	SMA Input (1X): < 1.5 mV (After Auto-Zero) <i>With tip cable: (SMA Input offset voltage) · (Tip cable input attenuation)⁸ scales proportionally to tip attenuation</i>					
Propagation Delay	2 m fiber cable: 15 ns <i>The probe specific value is measured and printed on interface box label, tip cable approx. 500 ps</i>					
Battery Life	> 30 h @ 22 °C – 25 °C, > 20 h @ 0 °C, > 4 h @ 50 °C <i>Dependent on probe head operating temperature (Continuous Operation)</i>					
Output Termination & Coupling	50 Ω DC					
Battery Type	Protected 18650 Li-Ion, Rechargeable, 3.7V Certified					
Laser Certification	Laser Class 1 IEC/EN 60825-1:2014, US 21CFR Part 1010, US 21CFR Part 1040					

Notes:

* Guaranteed specification

¹ Determined when using a PS-02 power supply at +23°C ambient temperature.

² For input voltage and input impedance derating graphs review the FireFly® instruction manual.

³ Terminated, 50 Ω transmission line.

⁴ as defined in IEC 61010-1. Rated for indoor, dry location use only.

⁵ Galvanically isolated FireFly® probe head through fiber optic connection.

⁶ CMRR performance is >180dB below 500kHz. See CMRR graph.

⁷ Example: 10x tip FF-MMCX-10V noise = 10x SMA input noise.

⁸ Example: 10x tip FF-MMCX-10V offset = 10x SMA input offset.

Environmental Specifications

Parameter		Specification	
Temperature Range	Operating	Probe Head	0 °C to +50 °C
		Interface Box	0 °C to +40 °C
		Tip Cables & Adapters	-40 °C to +85 °C
	Non-Operating	Probe Head & Interface Box	-20 °C to +71 °C
		Tip Cables & Adapters	-40 °C to +85 °C
Maximum Relative Humidity	Operating	Probe Head	5 % to 85 % RH (relative humidity) at up to +40 °C, 5 % to 45 % RH above +40 °C up to +50 °C, non-condensing
		Interface Box	5 % to 85 % RH (relative humidity) at up to +40 °C, non-condensing
	Non-Operating	Tip Cables & Adapters	5% to 85% RH (relative humidity) at up to +85 °C, non-condensing
		Probe Head & Interface Box	5 % to 85 % RH (relative humidity) at up to +40° C, 5 % to 45 % RH above +40° C up to +71° C, non-condensing
Maximum Altitude	Operating		3000 m (9843 ft)
	Non-Operating		15000 m (49213 ft)

Physical Specifications

Parameter	Specification	
Weight	Probe	325 g
	Tip Cable	11 g
Length	Tip Cable	9.5 cm (3.74")
	Fiber Cable	2 m (6.56 ft)
Connectors	Probe	Input: SMA (Female) – Probe Head Output: BNC (Male) - Interface Box

Dimensions

The dimensions shown are in mm. Drawings from the probe tips are coming soon. If the needed drawing is missing, please contact us via sales@pmk.de

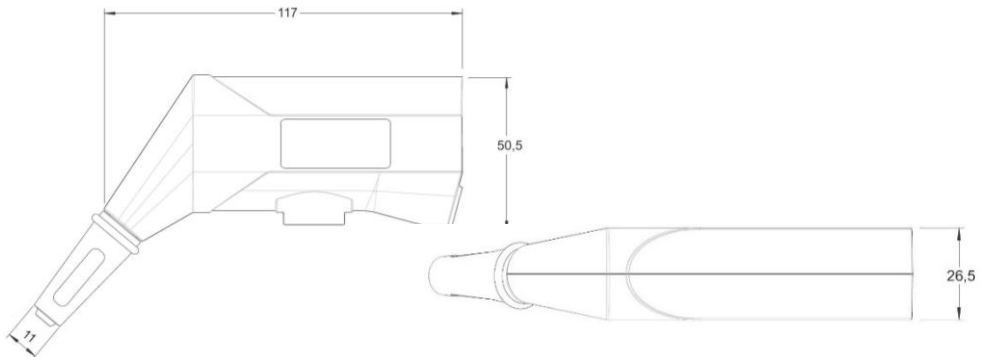

Typical Common Mode Rejection Ratio (CMRR)

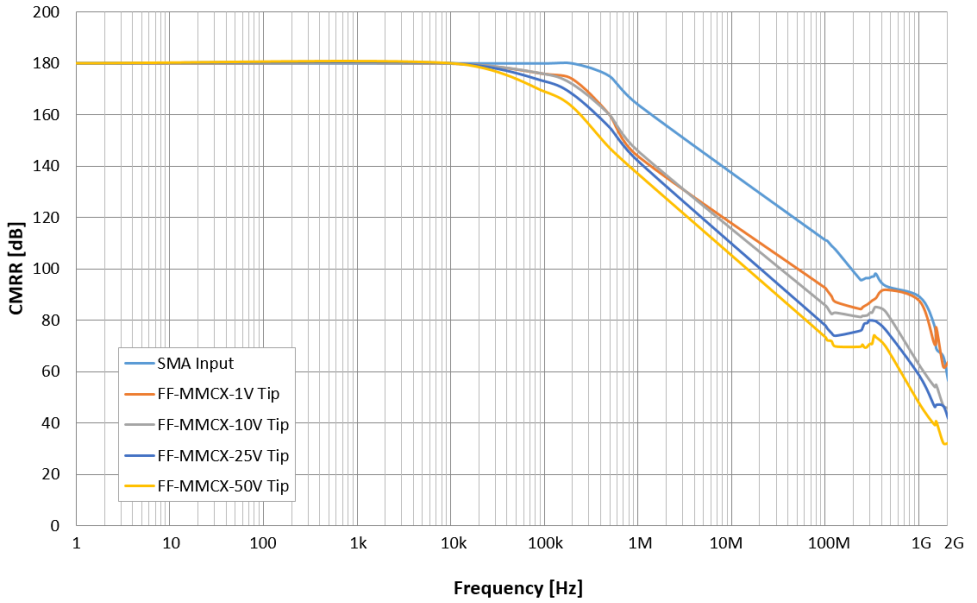

Typical Maximum Differential Input Voltage (CW)



Note that the maximum input voltage rating of the probe decreases as the frequency of the applied signal increases.

The maximum input voltage derating is coming soon.

Typical Frequency Response

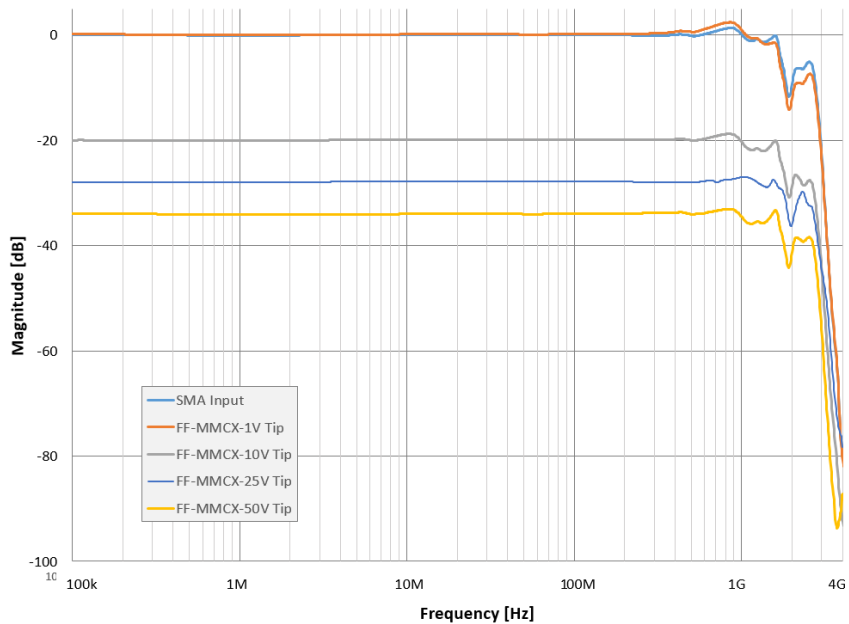

Typical Pulse Response

The graphs are normalized to 1 for better comparison.

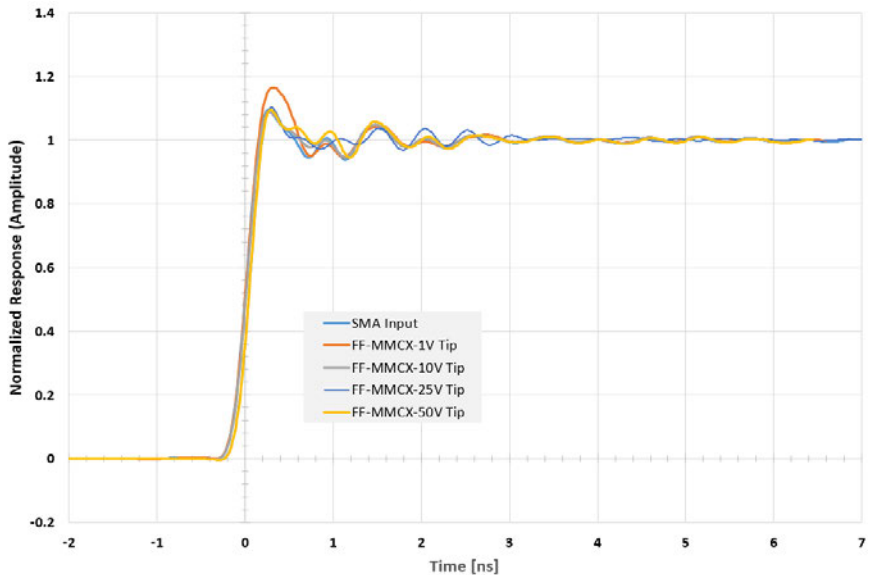

Typical Differential Input Impedance



Note that the maximum input voltage rating of the probe decreases as the frequency of the applied signal increases.

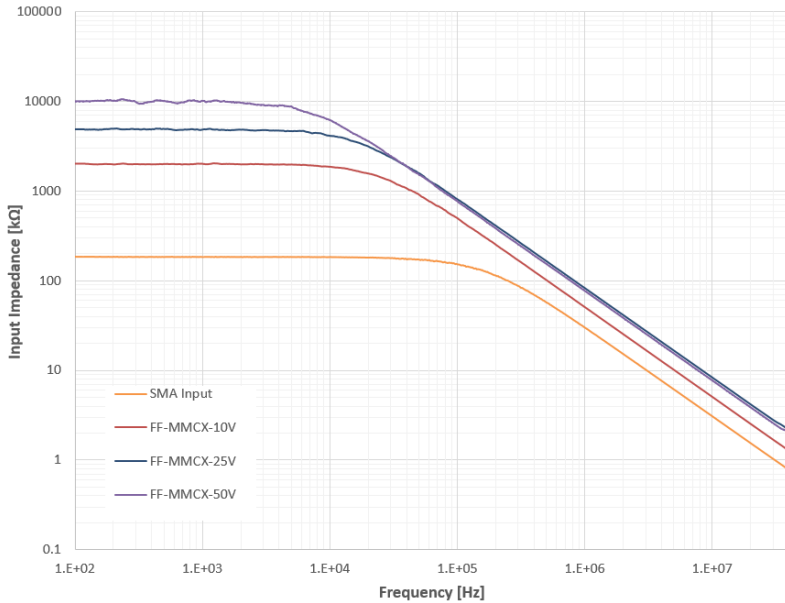





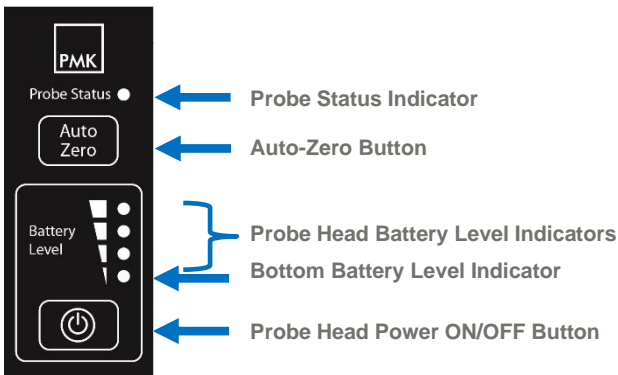

User Interface

Interface Box Controls & Indicators







Probe Status Indicator

Indicator		Status	Action/Information
	Green (Solid)	READY Probe Head Power ON	Successful powered up and probe head is on and warmed up. Ready for measurements.
	Green (Blinking)	Auto-Zero In Process	Auto-Zero is in process - Very fast. Probe head not ready. De-energized circuit under test before performing an Auto-Zero.
	Red (Solid)	Probe Head Power OFF	Caution - Probe Head is powered OFF and not able to pass a signal. Probe head not ready.
	Yellow (Solid)	Probe Head Warm Up	Probe head has successfully powered up and warming up. Probe head not ready. Do not energize your circuit under test.
	Blue (Solid)	Power Up	Powering up and running self-checks. Probe head not ready. Do not energize your circuit under test.
	Red (Blinking)	Error Condition	An error condition has occurred - Power cycle the probe & check probe head battery. Probe head not ready. Do not energize your circuit under test.

Probe Head Battery Level Indicators

The Battery Level Indicators will illuminate after the Probe Head is turned on.

Indicator		Status	Action/Information
	Green (Solid)	Normal Operation 1 - 4 Green LEDs	Ready for measurements. Four (4) Solid Green LEDs indicates the battery is full and One (1) Solid Green LED indicates the battery will soon need to be replaced.
	Bottom Green (Blinking)	Low Battery	Battery replacement recommended.
	Bottom Orange (Blinking)	Low Battery (Critical Warning)	Warning - Battery needs to be changed.
	Bottom Red (Blinking)	Empty or NO Battery Installed	Action required: Probe Head is NO longer in operation and passing a signal - De-energize your circuit - Check and replace battery

Probe Head Power ON/OFF Button

Turn the probe head ON before use and power OFF after use to conserve the battery. The Interface Box will power up even if the probe head is in the Probe Head OFF mode. See Probe Status Indicator Information.



When the Probe Head is in the OFF mode, the probe will not pass a signal.

Auto-Zero Button

Press the Auto-Zero Button on the probe interface box to remove any DC offset errors (drift) in the probe's output. See Probe Status Indicator overview for more information.



Make sure the circuit-under-test is de-energized. No signal must be applied to probe tip.

Remote Interface

COMING SOON: The "PMK Probe Control" software, available free of charge, provides the ability for the user to control the probe remotely via a computer, and provides the user with a graphical user interface. Download: www.pmk.de/probecontrol

In order to achieve the highest CMRR and minimum CM loading, keep the probe head away from surrounding metal or earth ground.

Getting Started

Read the Safety and Handling Information, the Specifications and the entire Instruction Manual before first use, and keep them for future reference. A digital copy of the latest revision can be downloaded at www.pmk.de

Cable Selection

Each tip cable has a set of labels on them that specify the linear input voltage range as well as the attenuation factor to correctly setup the scale factor on the oscilloscope to display the correct signal amplitudes. When selecting a tip cable for the measurement being made, consider the following criteria:

- 1) Maximum DC + AC peak voltage at the test point to be measured
- 2) Minimum differential loading (input resistance and capacitance) that test circuit can tolerate
- 3) Minimum needed sensitivity for the measurement (minimum V/div setting)

Probe Setup

- 1) **Connect the FireFly® Interface Box** to the BNC input of the oscilloscope or other measurement system with either an internal or external 50Ω input termination. If using a tip cable, attach the tip cable to the probe head SMA connector by turning it clockwise until fully tightened, so the tip cable is secure and not loosen up when in use. Set the propagation delay on the oscilloscope to the measured propagation value printed on the FireFly® Interface Box's label and add the tip cable/accessory delay if one is used. Set the oscilloscope's attenuation scale factor to the tip cable's attenuation.
- 2) **Connect the PMK Power Supply**, model 2ch PS2, 4ch PS3 or battery pack AP-01, to the power connector on the FireFly® Interface Box using a PMK Probe Connection Cable. Turn on the Power Supply. The Interface Box Probe Status Indicator turns red and the Probe Head Battery Level Indicators will light to indicate the probe head's battery level.



The power supply pin assignment is different from other power supplies. Use only original PMK power supplies with PMK probes.

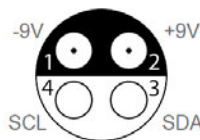

Probe's power supply pin assignment "cable view"



Before handling the probe head, tip cable or tip cable accessories, make sure the circuit-under-test is either de-energized or not connected to the probe.

3) Insert or Replace the battery

Open the probe head's battery compartment by unscrewing the battery cap counter-clockwise. *Insert* or replace the existing battery with a fully charged 18650 rechargeable battery, in order to achieve the longest probe head operating time. Follow the polarity markings on the compartment.

Make sure that the positive end of the battery goes in first and the negative end of the battery is facing out, towards the battery cap. Close the probe head's battery compartment by screwing the battery cap back onto the probe head in the clockwise direction and tighten.

4) Power ON/OFF the Probe Head

Press the Probe Head Power ON/OFF Button to turn on the probe head. Battery indicators will only illuminate when the Probe Head Power is turned ON and will turn off when Probe Head Power is turned OFF. Wait for the Probe Status Indicator on the interface box to turn green, which means the probe is now ready to make a measurement.

5) Connect the insulating probe holder

Connect the probe head to the FireFly® probe holder by aligning the attachment interface and then rotating it 90° to securely lock the probe head and holder together. If another probe holder is being used, use non-conducting probe holders only.



Insert / remove probe



Make sure probe head is fully inserted and seated into holder

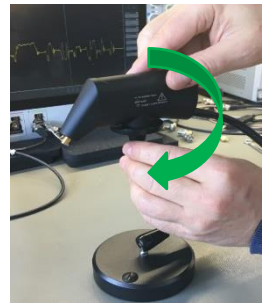

Twist by 90° to mount or unmount

6) Attach the probe tip cable or accessory input connector to the circuit-under-test. When using an MMCX connector, insert the tip cable's MMCX plug straight into the mating socket until a "click" sound occurs to indicate a proper connection between the plug and socket. When removing the tip cable from the MMCX socket, grasp the tip cable's MMCX connector and pull straight out, taking care not to wiggle the connector side-to-side to prevent excessive stresses on the socket and its connection to the DUT.

7) Auto-Zero button

Press the Auto-Zero button on the interface box to remove any DC offset errors (drift) in the probe's output.

8) Ready for making the measurements: Apply power to the circuit-under-test to begin making the measurements. To achieve the most stable measurements, allow the probe to warm up for 20 minutes.



Connection to the Test Points (Circuit-Under-Test)

To achieve the best performance from the FireFly® probe, use an MMCX connector as close to the test point as possible. The MMCX connectors provide a compact footprint and solid metal body that provide the best signal fidelity of the signal being measured as well as shielding

down as close as possible to the test point. This connection also provides a stable and repeatable measurement.

To achieve the best electrical performance, especially the CMRR performance and EMI susceptibility, place the probe tip adapter/accessories as close as possible to the circuit board.

To minimize the effects of common mode capacitive loading of the probe head/tip cable and maximum CMR, consider the following items.

- Whenever possible, connect the coaxial (common) shield of the tip cable to the test point that has the least dynamic signal, with respect to earth ground, relative to the tip cable signal (center) test point in the circuit-under-test.
- The coaxial (common) shield of the tip cable and tip cable adapters should always be connected to the lowest impedance point (usually a circuit common or power supply rail) in the circuit-under-test (relative to the tip cable/center conductor) to obtain the most accurate waveform.
- Increasing the physical distance between the probe head/tip cable and any conductive surface will reduce the parasitic capacitance.

Making the Measurement

Tips for making the highest signal fidelity measurements:

- To achieve the best CMRR performance, make sure to tighten the tip cable to probe SMA connection.
- Measure as close as possible to the desired measurement point.
- Avoid fiber movement when making a precise measurement.
- If use a tip cable adapter/accessory with input leads, twist the input leads together to reduce the input inductance and improve the CMRR of the test setup.
- Add external ferrite beads over the tip cable or adapter/accessory as close as possible to the test points will improve the CMRR and common mode loading on the circuit-under-test.

Scope of Delivery

Not all required items are included in the scope of delivery of the base probe FireFly® FF-1500. See Ordering Information to configure your individual probing solution and select a required PMK power supply. The following accessories are included in the scope of delivery.

- FireFly® FF-1500 base Probe, $\pm 1V$ input range
- 2x 18650 rechargeable Lithium Ion batteries
- USB Wall charger + USB cable (for battery charging) *Charger type may vary by region*
- Interface box probe connection cable (0.5m), 890-520-900
- Probe head holder 2-Footer (Bi-Pod), FF-2FOOTER
- Set cable coding rings (3x4 colors)
- Instruction Manual



The accessories for this probe series have been safety tested.
Do not use any other accessories, batteries or power supplies than what is recommended.

Ordering Information

Step 1: Select Base Probe

FF-1500	FireFly® optical isolated probe, 1.5GHz, >180dB, 2m fiber cable (2 batteries and 2footer included, required power supply to be ordered separately)
----------------	--

Step 2: Select Probe Tip Cables

The probe tip cables are interchangeable without requiring any tools. The probe head SMA input range is $\pm 1V$ with no attenuation.

FF-MMCX-1V	FireFly® probe tip cable, MMCX, $\pm 1V$, >1.5GHz, 1x attenuation, 50 Ω terminated for shunt measurements
FF-MMCX-10V	FireFly® probe tip cable, MMCX, $\pm 10V$, >1.3GHz, 10x attenuation
FF-MMCX-25V	FireFly® probe tip cable, MMCX, $\pm 25V$, >1.3GHz, 25x attenuation
FF-MMCX-50V	FireFly® probe tip cable, MMCX, $\pm 50V$, >1.3GHz, 50x attenuation
FF-MMCX-250V	FireFly® probe tip cable, MMCX, $\pm 250V$, TBD GHz, 250x attenuation
FF-WSQ-500V	FireFly® probe tip cable for 5.08mm square pins, $\pm 500V$, TBD GHz, 500x attenuation
FF-WSQ-1000V	FireFly® probe tip cable for 5.08mm square pins, $\pm 1000V$, TBD GHz, 1000x attenuation
FF-WSQ-2500V	FireFly® probe tip cable for 5.08mm square pins, $\pm 2500V$, TBD GHz, 2500x attenuation

Step 3: Select Connectivity Accessories

Observe the frequency derating of each accessory. Observe maximum input voltage of the probe's input. Do not use any other accessories.

FF-SQ-MMCX5

5x MMCX to 2x 0.025" (0.635mm) socket , -40°C to +125°C



FF-HTSPAD-MMCX3

3x MMCX solder-in cable adapter HT, 50 Ω RF micro coax to flex solder-in pad, -40°C to +155°C (green = 0 Ω , yellow = 36 Ω , red = 75 Ω)



FF-HTS-MMCX2

2x MMCX solder-in cable adapter HT, MMCX socket with 50 Ω RF micro coax cable and open end, -40°C to +155°C



FF-UFL-MMCX2

2x MMCX cable adapter, MMCX socket with 50 Ω RF micro coax cable to UFL plug, -40°C to +125°C





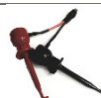

FF-2XR-MMCX

MMCX to 2x XR Mini-Hook





Continues on next page.

Observe the frequency derating of each accessory. Observe maximum input voltage of the probe's input. Do not use any other accessories.

972416100	2-pole test clip SMD for use with FF-SQ-MMCX5	
P25-2	Pico Hook™ red for use with FF-SQ-MMCX5	
P25-0	Pico Hook™ black for use with FF-SQ-MMCX5	
D010031	50Ω BNC feed-through for 1MΩ input oscilloscopes	

Step 4: Select Positioning System

FF-2FOOTER	Probe positioner 2-Footer (Bipod), included in probe's scope of delivery	
FF-3DPOS200	3D positioner with steel base, 200 mm span width and FireFly® probe holder, max 10kV	
FF-HAL10kV-3	FireFly® probe holder, max 10kV for use with PMK's 3D Probe Positioning Systems and SKID Probes and PCB Board holder systems, no stand-alone use	

Step 5: Select Power Supply

A PMK power supply PS2 or PS3 is required for using the probe.



The power supply pin assignment is different from other power supplies. Use only original PMK power supplies with PMK probes.

889-09V-PS2	PS-02 (2 channels, with USB interface for remote control)
889-09V-PS2-L	PS-02-L (2 channels, with LAN and USB interface for remote control)
889-09V-PS3	PS-03 (4 channels, with USB interface for remote control)
889-09V-PS3-L	PS-03-L (4 channels, with LAN and USB interface for remote control)
889-09V-AP01	AP-01 (battery pack, 1 channel, no remote control)
890-520-900	Power supply cable (0.5 m), included in probe's scope of delivery
890-520-915	Power supply cable (1.5 m)

Observe Connector Pin-Out
for PMK power supply cables

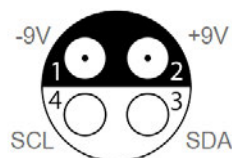

Step 6: Select Accredited Calibration

KAL-DAKKS-FF	ISO 17025 (re-)calibration
---------------------	----------------------------

Step 7: Select Additional Accessories

D010031	50Ω BNC feedthrough for use with 1MΩ oscilloscope inputs, 0.5W
----------------	--

Coming Soon / In Development

New connectivity solutions

Power-Over-Fiber adapter

If you need any non-published accessory, please contact us via sales@pmk.de

The logo for dataTec, featuring the word "dataTec" in a white, italicized, sans-serif font. The "a" has a horizontal bar through it. The logo is centered within a solid red rectangular background.

Mess- und Prüftechnik. Die Experten.

**Ihr Ansprechpartner /
Your Partner:**

dataTec AG

E-Mail: info@datatec.eu

>>> www.datatec.eu

Copyright © 2023 PMK - All rights reserved.

Information in this publication supersedes that in all previously published material.
Specifications are subject to change without notice.

Informationen in dieser Anleitung ersetzen die in allen bisher veröffentlichten Dokumenten.
Änderungen der Spezifikationen vorbehalten.