



PXIE-SCP5100 Bundle

Expandable PXI bundle based on PXIe-5105
Oscilloscope, 60 MHz, 12 bits, 8 Channels, 128 MB

Specifications

PXIE-1083 and PXIE-5105



Ihr Ansprechpartner /
Your Partner:

dataTec AG
E-Mail: info@datatec.eu
>>> www.datatec.eu

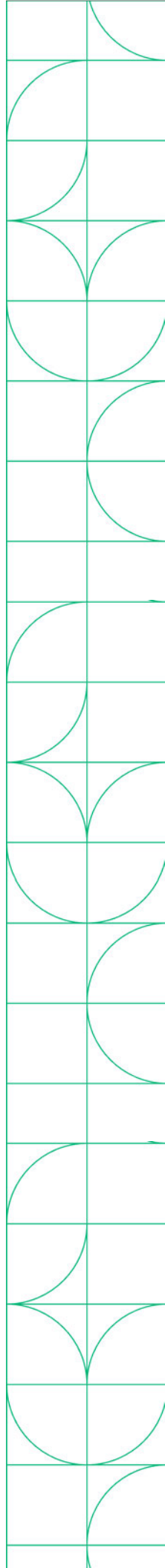

PXI Oscilloscope Bundle

In the Box

PXIe-SCP5100 Bundle

Bundle P/N: 867010-01



PXIe-5105
(Oscilloscope)



PXIe-1083
(5-Slot PXIe Chassis)

Accessories:

- SMB Female to Mini-Alligator Clips (x2)
- Thunderbolt cable
- Power cable, US

Recommended Software

Test Workflow P/N: 788509-35



Test Workflow is a bundle of select NI software featuring engineering-specific tools that help test professionals accomplish anything from their day-to-day work to overcoming their most challenging obstacles.

Test Workflow includes:

- **LabVIEW** - a graphical programming environment engineers use to develop automated research, validation, and production test systems.
- **InstrumentStudio** - an application software that provides an integrated approach to interactive PXI measurements.
- **TestStand** - a test executive software that accelerates system development and deployment for engineers in validation and production.
- And more NI Software!

Table of Contents

This document combines the PDFs of this bundle together. The page numbers in the table of contents correspond to the page number of PDF the component's documentation begins.

PXIe-1083 Specifications.....	3
PXIe-5105 Specifications.....	16



PXIe-1083

Specifications



PXIe-1083 Specifications

This document contains specifications for the PXIe-1083 chassis.

Electrical

The following section provides information about the PXIe-1083 AC input and DC output.

AC Input

Input rating	100 VAC to 240 VAC, 50 Hz/60 Hz, 6 A to 3 A
Operating voltage range ¹	90 VAC to 264 VAC
Nominal input frequency	50 Hz/60 Hz
Operating frequency range ¹	47 Hz to 63 Hz
Efficiency	78% typical
Over-current protection	Internal fuse in line
Main power disconnect	The AC power cable provides main power disconnect. Do not position the equipment so that it is difficult to disconnect the power cord. The front-panel power switch causes the internal chassis power supply to provide DC power to the PXI Express backplane.



Caution Disconnect power cord to completely remove power.

DC Output

DC output characteristics of the PXIe-1083.

Voltage Rail	Maximum Current	Load Regulation	Maximum Ripple and Noise (20 MHz BW)
+5V_AUX	1.0 A	±5%	50 mVpp
+12 V	30.1 A	±5%	120 mVpp
+5 V	25.1 A	±5%	50 mVpp
+3.3 V	30.7 A	±5%	50 mVpp
-12 V	0.75 A	±5%	120 mVpp

Maximum total available power for the PXIe-1083 is 293 W.

The maximum combined power available on +3.3 V and +5 V is 180 W.

The maximum power available for each Thunderbolt port is 15 W (5 V/3 A).

Table 1. Backplane Slot Current Capacity

Slot	+5 V	V(I/O)	+3.3 V	+12 V	-12 V	5 V _{AUX}
Hybrid Peripheral Slot with PXI-5 Peripheral	-	-	3 A	6 A	-	1 A
Hybrid Peripheral Slot with PXI-1 Peripheral	6 A	5 A	6 A	1 A	1 A	-



Note PCI V(I/O) pins in Hybrid Peripheral Slots are connected to +5 V.



Note The maximum power dissipated in a peripheral slot should not exceed 58 W. Refer to the **Operating Environment** section for ambient temperature considerations at 58 W.

Over-current protection	All outputs are protected from short circuit and overload, they recover and return to regulation when the overload is removed and the power is cycled.
Over-voltage protection	+3.3 V clamped at 3.7 V to 4.3 V, +5 V clamped at 5.7 V to 6.5 V, +12 V clamped at 13.4 V to 15.6 V

Chassis Cooling

Module cooling	Forced air circulation (positive pressurization) through one 150 CFM fan
Module slot airflow direction	Bottom of module to top of module
Module intake	Bottom of chassis
Module exhaust	Top, right side of chassis
Slot cooling capacity	58 W; slot 6 supports 58 W cooling with high fan mode
Power supply cooling	Forced air circulation through integrated fans
Power supply intake	Front and left side chassis
Power supply exhaust	Rear of chassis
Minimum chassis cooling clearances	
Above	44.45 mm (1.75 in.)
Rear	44.45 mm (1.75 in.)
Sides	44.45 mm (1.75 in.)
Below	
Rack	44.45 mm (1.75 in.)
Desktop	25.4 mm (1.00 in.)

Environmental

Maximum altitude	2,000 m (6,560 ft.), 800 mbar (at 25 °C ambient, high fan mode)
Pollution Degree	2

Indoor use only.

Operating Environment

<p>Ambient temperature range</p> <p>When all peripheral modules require ≤ 38 W cooling capacity per slot</p> <p>0 °C to 50 °C (IEC 60068-2-1 and IEC 60068-2-2.)² Meets MIL-PRF-28800F Class 3 low temperature limit and high temperature limit.</p> <p>When any peripheral module requires > 38 W cooling capacity per slot</p> <p>0 °C to 40 °C (IEC 60068-2-1 and IEC 60068-2-2.)² Meets MIL-PRF-28800F Class 3 low temperature limit and MIL-PRF-28800F Class 4 high temperature limit.</p>	
Relative humidity range	20% to 80%, noncondensing

Storage Environment

Ambient temperature range	-40 °C to 71 °C (IEC-60068-2-1 and IEC-60068-2-2.) ^[3] Meets MIL-PRF-28800F Class 3 limits.
Relative humidity range	10% to 95%, noncondensing

Shock and Vibration

Operational shock	30 g peak, half-sine, 11 ms pulse (IEC-60068-2-27.) ³ Meets MIL-PRF-28800F Class 2 limits.
Operational random vibration	5 to 500 Hz, 0.3 g _{rms}
Non-operating vibration	5 to 500 Hz, 2.4 g _{rms} (IEC 60068-2-64.) ³ Non-operating test profile exceeds the requirements of MIL-PRF-28800F, Class 3.

Acoustic Emissions

Sound Pressure Level (at Operator Position)

(Tested in accordance with ISO 7779. Meets MIL-PRF-28800F requirements.)

38 W Profile

Auto fan (up to 30 °C ambient)	33.7 dBA
High fan	50.8 dBA

58 W Profile

Auto fan (up to 30 °C ambient)	54.7 dBA
High fan	55.3 dBA

Sound Power Level

38 W Profile

Auto fan (up to 30 °C ambient)	44.9 dBA
High fan	60.3 dBA

58 W Profile

Auto fan (up to 30 °C ambient)	63.4 dBA
High fan	64.2 dBA



Note The protection provided by the PXIe-1083 can be impaired if it is used in a manner not described in this document.

Safety Compliance Standards

This product is designed to meet the requirements of the following electrical equipment safety standards for measurement, control, and laboratory use:

- IEC 61010-1, EN 61010-1
- UL 61010-1, CSA C22.2 No. 61010-1



Note For safety certifications, refer to the product label or the [Product Certifications and Declarations](#) section.

EMC Guidelines

This product was tested and complies with the regulatory requirements and limits for electromagnetic compatibility (EMC) stated in the product specifications. These requirements and limits provide reasonable protection against harmful interference when the product is operated in the intended operational electromagnetic environment.

This product is intended for use in industrial locations. However, harmful interference may occur in some installations, when the product is connected to a peripheral device or test object, or if the product is used in residential areas. To minimize interference with radio and television reception and prevent unacceptable performance degradation, install and use this product in strict accordance with the instructions in the product documentation.

Furthermore, any changes or modifications to the product not expressly approved by NI could void your authority to operate it under your local regulatory rules.

EMC Notices

Refer to the following notices for cables, accessories, and prevention measures necessary to ensure the specified EMC performance.



Notice

For EMC declarations and certifications, and additional information, refer to the [Product Certifications and Declarations](#) section.



Notice Changes or modifications to the product not expressly approved by NI could void your authority to operate the product under your local regulatory rules.



Notice Operate this product only with shielded cables and accessories.

Electromagnetic Compatibility Standards

This product meets the requirements of the following EMC standards for electrical equipment for measurement, control, and laboratory use:

- EN 61326-1 (IEC 61326-1): Class A emissions; Basic immunity
- EN 55011 (CISPR 11): Group 1, Class A emissions

- AS/NZS CISPR 11: Group 1, Class A emissions



Note Group 1 equipment (per CISPR 11) is any industrial, scientific, or medical equipment that does not intentionally generate radio frequency energy for the treatment of material or inspection/analysis purposes.



Note In Europe, Canada, Australia, and New Zealand (per CISPR 11) Class A equipment is intended for use in nonresidential locations.

CE Compliance

This product meets the essential requirements of applicable European Directives, as follows:

- 2014/35/EU; Low-Voltage Directive (safety)
- 2014/30/EU; Electromagnetic Compatibility Directive (EMC)
- 2011/65/EU; Restriction of Hazardous Substances (RoHS)

Product Certifications and Declarations

Refer to the product Declaration of Conformity (DoC) for additional regulatory compliance information. To obtain product certifications and the DoC for NI products, visit ni.com/product-certifications, search by model number, and click the appropriate link.

Environmental Management

NI is committed to designing and manufacturing products in an environmentally responsible manner. NI recognizes that eliminating certain hazardous substances from our products is beneficial to the environment and to NI customers.

For additional environmental information, refer to the **Engineering a Healthy Planet** web page at ni.com/environment. This page contains the environmental

regulations and directives with which NI complies, as well as other environmental information not included in this document.

EU and UK Customers

-  Waste Electrical and Electronic Equipment (WEEE)—At the end of the product life cycle, all NI products must be disposed of according to local laws and regulations. For more information about how to recycle NI products in your region, visit ni.com/environment/weee.

电子信息产品污染控制管理办法 (中国 RoHS)

-  中国 RoHS— NI 符合中国电子信息产品中限制使用某些有害物质指令(RoHS)。关于 NI 中国 RoHS 合规性信息，请登录 ni.com/environment/rohs_china。(For information about China RoHS compliance, go to ni.com/environment/rohs_china.)

Backplane

Size	3U-sized; 5 peripheral slots. Compliant with IEEE 1101.10 mechanical packaging. PXI Express Specification compliant. Accepts both PXI Express and CompactPCI (PICMG 2.0 R 3.0) 3U modules.
Backplane bare-board material	UL 94 V-0 Recognized
Backplane connectors	Conforms to IEC 917 and IEC 1076-4-101, UL 94 V-0 rated

System Synchronization Clocks

10 MHz System Reference Clock: PXI_CLK10

Maximum slot-to-slot skew	250 ps
Accuracy	± 25 ppm max (guaranteed over the operating temperature range)
Maximum jitter	5 ps RMS phase-jitter (10 Hz–1 MHz range)
Duty-factor	45% to 55%
Unloaded signal swing	3.3 V \pm 0.3 V



Note For other specifications, refer to the **PXI-1 Hardware Specification**.

100 MHz System Reference Clock: PXIe_CLK100 and PXIe_SYNC100

Maximum slot-to-slot skew	100 ps
Accuracy	± 25 ppm max (guaranteed over the operating temperature range)
Maximum jitter	3 ps RMS phase-jitter (10 Hz to 12 kHz range), 2 ps RMS phase-jitter (12 kHz to 20 MHz range)
Duty-factor for PXIe_CLK100	45% to 55%
Absolute differential voltage (When terminated with a 50 Ω load to 1.30 V or Thévenin equivalent)	400 mV to 1000 mV



Note For other specifications, refer to the **PXI-5 PXI Express Hardware Specification**.

Mechanical

Standard chassis dimensions	
Height	177.1 mm (6.97 in.)
Width	257.1 mm (10.12 in.)
Depth	214.2 mm (8.43 in.)
Weight	6.7 kg (14.8 lb)
Chassis materials	Extruded Aluminum (6063-T5, 6060-T6), Cold Rolled Steel/Stainless Steel, Santoprene, Urethane Foam, PC-ABS, Nylon, Polyethylene
Finish	Conductive Clear Iridite on Aluminum, Electroplated Nickel on Cold Rolled Steel, Electroplated Zinc on Cold Rolled Steel

The following figures show the PXIe-1083 chassis dimensions. The holes shown are for installing the optional rack mount kits.

Figure 1. PXIe-1083 Chassis Dimensions (Front)

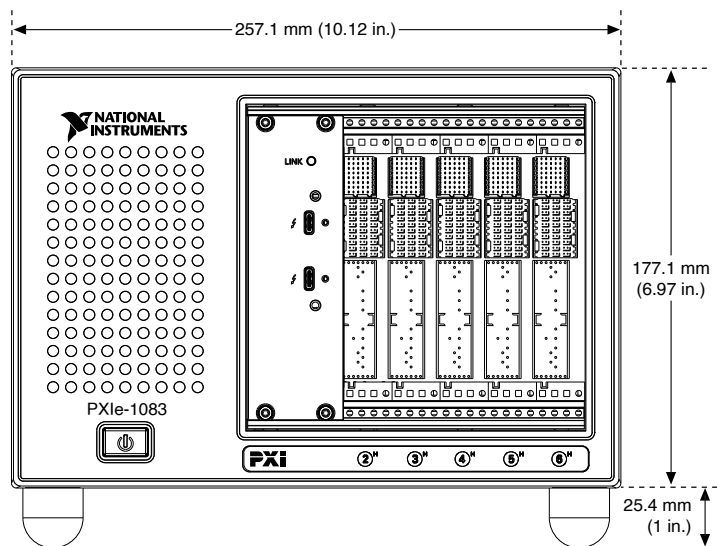

Figure 2. PXIe-1083 Chassis Dimensions (Side)

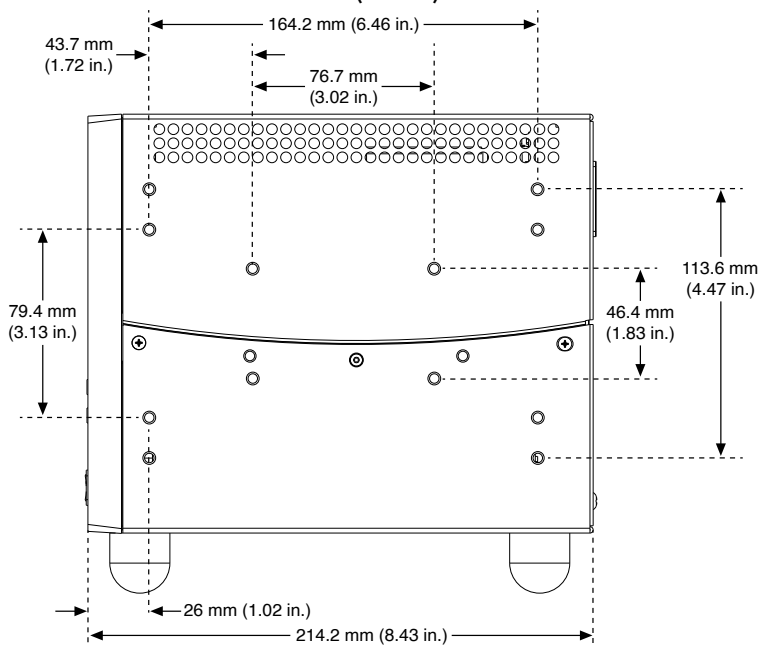
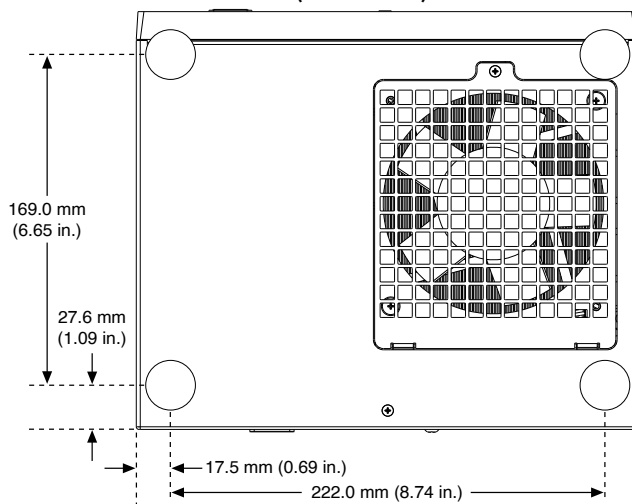

Figure 3. PXIe-1083 Chassis Dimensions (Bottom)



¹ The operating range is guaranteed by design.

² This product meets the requirements of the environmental standards for electrical equipment for measurement, control, and laboratory use.

³ This product meets the requirements of the environmental standards for electrical equipment for measurement, control, and laboratory use.

PXle-5105 Specifications



PXIe-5105 Specifications

Definitions

Warranted specifications describe the performance of a model under stated operating conditions and are covered by the model warranty. Warranted specifications account for measurement uncertainties, temperature drift, and aging. Warranted specifications are ensured by design or verified during production and calibration.

Characteristics describe values that are relevant to the use of the model under stated operating conditions but are not covered by the model warranty.

- **Typical** specifications describe the performance met by a majority of models.
- **Nominal** specifications describe an attribute that is based on design, conformance testing, or supplemental testing.
- **Measured** specifications describe the measured performance of a representative model.

Specifications are **Typical** unless otherwise noted.

Conditions

Specifications are valid under the following conditions unless otherwise noted.

- All filter settings
- All impedance selections
- Sample clock set to 60 MS/s

Warranted specifications are valid under the following conditions unless otherwise noted.

- Temperature range of 0 °C to 55 °C

- The PXIe-5105 module is warmed up for 15 minutes at ambient temperature
- Calibration cycle is maintained
- The PXI Express chassis fan speed is set to HIGH, the foam fan filters are removed if present, and the empty slots contain PXI chassis slot blockers and filler panels. For more information about cooling, refer to the **Maintain Forced-Air Cooling Note to Users** available at ni.com/manuals.
- External calibration is performed at $23\text{ }^{\circ}\text{C} \pm 3\text{ }^{\circ}\text{C}$

Vertical

Analog Input

Number of channels	Eight (simultaneously sampled)
Input type	Referenced single-ended
Connectors	SMB

Impedance and Coupling

<p>Input impedance</p> <p>50 Ω 50 $\Omega \pm 2\%$</p> <p>1 MΩ 1 M$\Omega \pm 1\%$ in parallel with a nominal capacitance of 50 pF</p>	
Input coupling	AC ^[1] , DC

Voltage Levels

<p>Full-scale (FS) input range</p>

50 Ω and 1 M Ω	0.05 V
	0.2 V
	1 V
	6 V
1 M Ω only	30 V
Maximum input overload	
50 Ω	7 V _{rms} with Peaks \leq 10 V
1 M Ω	Peaks \leq 42 V

Accuracy

Resolution	12 bits
------------	---------

Table 1. DC Accuracy^[2]

Input Impedance	Input Range (V _{pk-pk})	DC Accuracy, Warranted
50 Ω	All	$\pm(1\% \times \mathbf{Reading} + 0.25\% \text{ of } \mathbf{FS} + 600 \mu\text{V})$
1 M Ω	0.05 V	$\pm(1\% \times \mathbf{Reading} + 0.25\% \text{ of } \mathbf{FS} + 600 \mu\text{V})$
	0.2 V, 1 V, and 6 V	$\pm(0.65\% \times \mathbf{Reading} + 0.25\% \text{ of } \mathbf{FS} + 600 \mu\text{V})$
	30 V	$\pm(0.75\% \times \mathbf{Reading} + 0.25\% \text{ of } \mathbf{FS} + 600 \mu\text{V})$
DC drift	$\pm(0.05\% \text{ of } \mathbf{Reading} + 0.02\% \text{ of } \mathbf{FS} + 20 \mu\text{V}) \text{ per } ^\circ\text{C}$	

Table 2. AC Amplitude Accuracy^[3]

Input Impedance	Input Range (V _{pk-pk})	AC Amplitude Accuracy
50 Ω	All	$\pm 0.1 \text{ dB } (\pm 1.2\%) \text{ of } \mathbf{Reading}$
1 M Ω	0.05 V	$\pm 0.2 \text{ dB } (\pm 2.3\%) \text{ of } \mathbf{Reading}$

Input Impedance	Input Range (V_{pk-pk})	AC Amplitude Accuracy
	0.2 V and 1 V	± 0.13 dB ($\pm 1.5\%$) of Reading
	6 V and 30 V	± 0.4 dB ($\pm 4.7\%$) of Reading

Table 3. Crosstalk^[4]

Input Impedance	Input Range (V_{pk-pk})	Crosstalk
50 Ω	All	≤ -80 dB at 1 MHz
1 M Ω	0.05 V	≤ -75 dB at 1 MHz
	0.2 V, 1 V, 6 V, and 30 V	≤ -80 dB at 1 MHz

Bandwidth and Transient Response

Table 4. Bandwidth (-3 dB)

Input Impedance	Input Range (V_{pk-pk})	Bandwidth
50 Ω	0.05 V	55 MHz
	0.2 V, 1 V, and 6 V	60 MHz
1 M Ω	0.05 V	35 MHz
	0.2 V, 1 V, 6 V, and 30 V	60 MHz

Bandwidth-limiting filter	24 MHz anti-alias filter
AC-coupling cutoff (-3 dB) ^[5]	12 Hz

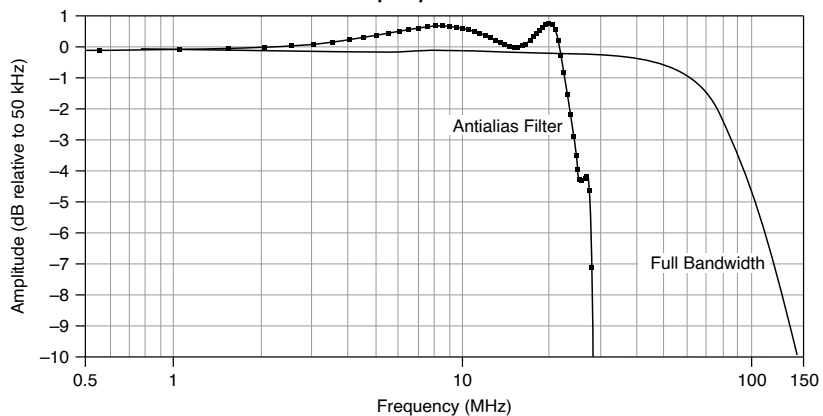
Figure 1. Frequency Response, 50 Ω , 1 V_{pk-pk} Input Range, Measured

Spectral Characteristics

1 M Ω Spectral Performance^[6]

Table 9. Spurious-Free Dynamic Range (SFDR)

Input Range (V_{pk-pk})	SFDR
0.2 V	70 dBc
1 V and 6 V	65 dBc

Table 10. Total Harmonic Distortion (THD)

Input Range (V_{pk-pk})	THD
0.05 V	-72 dBc
0.2 V	-75 dBc
1 V	-65 dBc
6 V	-68 dBc

Table 11. Signal to Noise and Distortion (SINAD)

Input Range (V_{pk-pk})	SINAD
0.05 V	50 dB
0.2 V	59 dB
1 V	61 dB
6 V	59 dB

1 M Ω Noise

Table 12. 1 M Ω RMS Noise^[7]

Input Range (V_{pk-pk})	Full Bandwidth	24 MHz Filter Enabled
0.05 V	0.18% of FS (90 μ V)	0.12% of FS (60 μ V)
0.2 V	0.060% of FS (120 μ V)	0.036% of FS (72 μ V)
1 V	0.03% of FS (300 μ V)	0.03% of FS (300 μ V)
6 V	0.055% of FS (3.3 mV)	0.036% of FS (2.16 mV)
30 V	0.03% of FS (9 mV)	0.03% of FS (9 mV)

50 Ω Spectral Performance

Table 9. Spurious-Free Dynamic Range (SFDR)^[8]

Input Range (V_{pk-pk})	SFDR
0.2 V	72 dBc
1 V and 6 V	72 dBc

Table 10. Total Harmonic Distortion (THD)^[8]

Input Range (V_{pk-pk})	THD
All	-75 dBc

Table 11. Signal to Noise and Distortion (SINAD)^[8]

Input Range (V_{pk-pk})	SINAD
0.05 V	59 dB
0.2 V to 6 V	62 dB

Figure 2. PXIe-5105 Dynamic Performance, 50 Ω , 1 V_{pk-pk} , with 24 MHz Filter Enabled, Measured

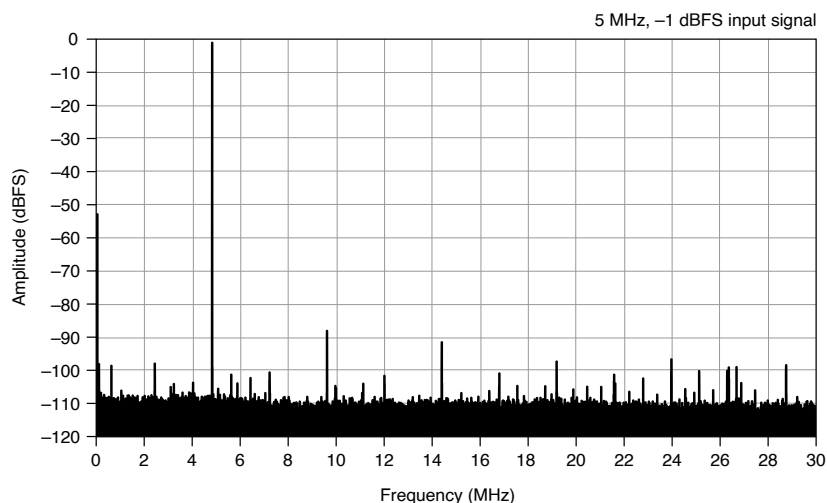
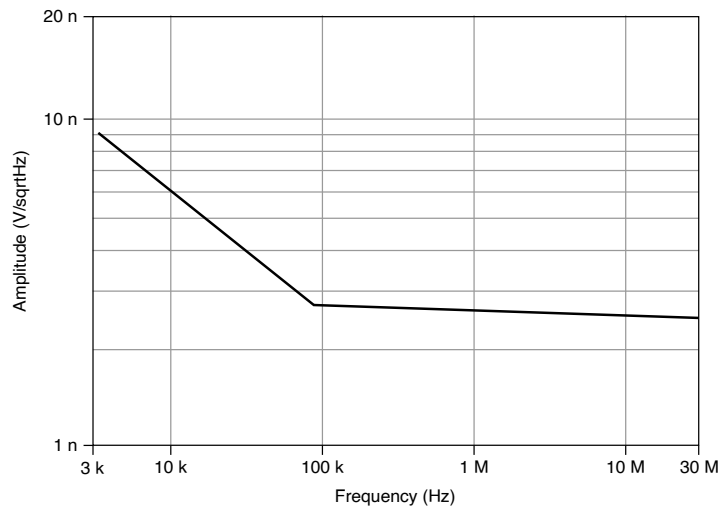

Figure 1. PXIe-5105 Spectral Noise Density, 50 Ω , 0.05 V_{pk-pk} , with Anti-Alias Filter Enabled, Nominal



50 Ω Noise

Table 12. 50 Ω RMS Noise^[9]

Input Range (V_{pk-pk})	Full Bandwidth	24 MHz Filter Enabled
0.05 V	0.08% of FS (40 μ V)	0.038% of FS (19 μ V)
0.2 V	0.04% of FS (80 μ V)	0.028% of FS (56 μ V)
1 V	0.03% of FS (300 μ V)	0.029% of FS (290 μ V)
6 V	0.03% of FS (1.8 mV)	0.028% of FS (1.68 mV)

Skew

Channel-to-channel skew^[10]

24 MHz bandwidth filter disabled	≤ 500 ps
24 MHz bandwidth filter enabled	≤ 600 ps

Horizontal Sample Clock

Sources	
Internal	Onboard clock (internal VCXO) ^[11]
External	PFI 1 PFI Star
External frequency range	4 MHz to 65 MHz
Exporting^[12]	
Destination	PFI 1
Maximum frequency	65 MHz

Onboard Clock (Internal VCXO)

Real-time sample rate range ^[13]	915.5 S/s to 60 MS/s
Timebase frequency	60 MHz
Timebase accuracy	
Not phase-locked to Reference clock	±25 ppm, warranted
Phase-locked to Reference clock	Equal to the Reference clock accuracy
Sample clock delay range	±1 Sample clock period

Sample clock delay resolution	<10 ps
-------------------------------	--------

External Sample Clock

Sources	PFI 1 PFI Star
Frequency range ^[14]	4 MHz to 65 MHz
Duty cycle tolerance	45% to 55%

Phase-Locked Loop (PLL) Reference Clock

Sources	PXI_CLK10 (backplane connector) PFI 1 (front panel SMB connector)
Frequency range ^[15]	5 MHz to 20 MHz in 1 MHz increments
Duty cycle tolerance	45% to 55%
Exported Reference clock destination	PFI 1

Triggers

Reference (Stop) Trigger

Supported trigger	Reference (stop) trigger
Trigger types	Edge

	Window
	Hysteresis
	Digital
	Immediate
	Software
Trigger sources	CH 0 to CH 7 PFI 1 PXI_Trig <0..6> Software
Time resolution	Sample clock timebase period
Minimum rearm time^[16]	
Internal Onboard clock	2.4 μ s
External Sample clock	144 \times External clock period
Holdoff	From rearm time up to $[(2^{32} - 1) \times \text{Sample clock timebase period}]$
Delay	From 0 up to $[(2^{32} - 1) - \text{Requested posttrigger samples}] \times (1/\text{Actual sample rate})$, in seconds

Related information

- [Refer to the NI High-Speed Digitizers Help for more information about which trigger sources are available for each trigger type.](#)

Analog Trigger

Trigger types	Edge Window Hysteresis
Sources	CH 0 to CH 7 (front panel SMB connectors)
Trigger level range	100% FS
Edge trigger sensitivity	2% FS
Trigger jitter	Sample clock timebase period

Digital Trigger

Trigger type	Digital
Sources	PFI 1 (front panel SMB connector) PXI_TRIG <0..6> (backplane connector)

Programmable Function Interface

Connector	PFI 1 (front panel SMB connector)
Direction	Bidirectional
Coupling	AC

DC

As a Sample Clock or Reference Clock

Input voltage range	
Sine wave	0.65 V _{pk-pk} to 2.8 V _{pk-pk} (0 dBm to 13 dBm)
Square wave	0.2 V _{pk-pk} to 2.8 V _{pk-pk}
Maximum input overload	7 V _{rms} with Peaks ≤ 10 V
Input impedance	50 Ω
Coupling	AC

As an Input (Digital Trigger)

Destinations	Start trigger (acquisition arm) Reference (stop) trigger Arm Reference trigger Advance trigger
Input impedance	150 kΩ, nominal
V _{IH}	2.0 V
V _{IL}	0.8 V

Maximum input overload	-0.5 V, 5.5 V
Maximum frequency	65 MHz

As an Output

Sources	Start trigger (acquisition arm) Reference (stop) trigger End of record Done (end of acquisition) Sample clock timebase Reference clock
Output impedance	50 Ω
Logic type	3.3 V CMOS
Maximum drive current	± 24 mA

Waveform Specifications

Onboard memory size options ^[17]	128 MB
Minimum record length	1 sample

Number of samples ^[18]	
Pretrigger	Zero up to full record length
Posttrigger	Zero up to full record length
Allocated onboard memory per record ^[19]	$[(\text{Record length in samples} \times 2 \text{ bytes/sample} \times \text{number of enabled channels}) + 480]$ rounded up to the nearest 256 bytes

Calibration

External Calibration

External calibration calibrates the onboard references used in self-calibration and the external trigger levels. All calibration constants are stored in nonvolatile memory.

Self-Calibration

Self-calibration is done on software command. The calibration corrects for gain, offset, triggering, and timing errors for all input ranges.

Calibration Specifications

Interval for external calibration	2 years
Warm-up time ^[20]	15 minutes

Software

Driver Software

Driver support for this device was first available in NI-SCOPE14.1.

NI-SCOPE is an IVI-compliant driver that allows you to configure, control, and calibrate the PXIe-5105. NI-SCOPE provides application programming interfaces for many development environments.

Application Software

NI-SCOPE provides programming interfaces, documentation, and examples for the following application development environments:

- LabVIEW
- LabWindows™/CVI™
- Measurement Studio
- Microsoft Visual C/C++
- .NET (C# and VB.NET)

Interactive Soft Front Panel and Configuration

When you install NI-SCOPE on a 64-bit system, you can monitor, control, and record measurements from the PXIe-5105 using InstrumentStudio.

InstrumentStudio is a software-based front panel application that allows you to perform interactive measurements on several different device types in a single program.



Note InstrumentStudio is supported only on 64-bit systems. If you are using a 32-bit system, use the NI-SCOPE-specific soft front panel instead of InstrumentStudio.

Interactive control of the PXIe-5105 was first available via InstrumentStudio in NI-SCOPE18.0 and via the NI-SCOPE SFP in NI-SCOPE14.1. InstrumentStudio and the NI-SCOPE SFP are included on the NI-SCOPE media.

NI Measurement & Automation Explorer (MAX) also provides interactive configuration and test tools for the PXIe-5105. MAX is included on the driver media.

TClk Specifications

You can use the NI TClk synchronization method and the NI-TClk driver to align the Sample clocks on any number of supported devices, in one or more chassis. For more information about TClk synchronization, refer to the **NI-TClk Synchronization Help**, which is located within the **NI High-Speed Digitizers Help**. For other configurations, including multichassis systems, contact NI Technical Support at ni.com/support.

Intermodule SMC Synchronization Using NI-TClk for Identical Modules

Specifications are valid for modules installed in one NI PXI-1042 chassis. These specifications do not apply to PCI modules. Specifications are valid under the following conditions:

- All parameters are set to identical values for each SMC-based module.
- Sample clock set to 60 MS/s.
- All filters are disabled.



Note Although you can use NI-TClk to synchronize non-identical modules, these specifications apply only to synchronizing identical modules.

Skew ^[21]	500 ps
Average skew after manual adjustment ^[22]	<10 ps
Sample clock adjustment resolution	<10 ps

Power

Current draw

+3.3 V DC

1.5 A

+12 V DC	1.5 A
Total power	23 W

Physical

Dimensions and Weight

Dimensions	21.4 cm × 2.0 cm × 13.0 cm (8.43 in. × 0.8 in. × 5.1 in.)
Weight	520 g (18.3 oz)

Figure 1. PXIe-5105

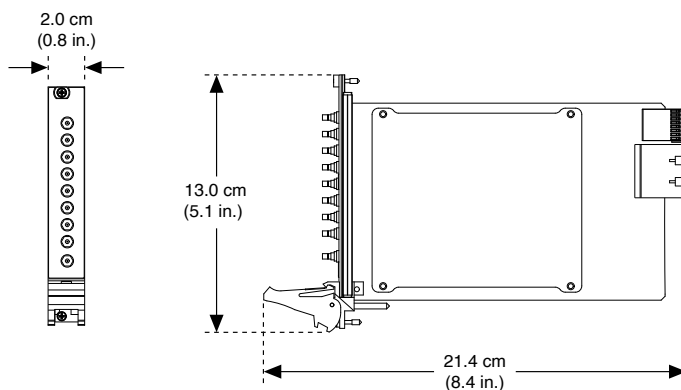

Front Panel Connectors

Table 13. PXIe-5105 Front Panel Connectors

Label	Connector Type	Description
CH 0—CH 7	SMB jack	Analog input connection; digitizes data and triggers acquisitions.
PFI 1		PFI line for trigger input/output, External clock in, Reference clock input/output, and timebase out.

Environment

Maximum altitude	2,000 m (800 mbar) (at 25 °C ambient temperature)
Pollution Degree	2

Indoor use only.

Operating Environment

Ambient temperature range	0 °C to 40 °C
Relative humidity range	10% to 90%, noncondensing

Storage Environment

Ambient temperature range	-40 °C to 71 °C
Relative humidity range	5% to 95%, noncondensing

Shock and Vibration

Operating shock	30 g peak, half-sine, 11 ms pulse
Random vibration	
Operating	5 Hz to 500 Hz, 0.3 grms
Nonoperating	5 Hz to 500 Hz, 2.4 grms

Compliance and Certifications

Safety Compliance Standards

This product is designed to meet the requirements of the following electrical equipment safety standards for measurement, control, and laboratory use:

- IEC 61010-1, EN 61010-1
- UL 61010-1, CSA C22.2 No. 61010-1



Note For safety certifications, refer to the product label or the [Product Certifications and Declarations](#) section.

Electromagnetic Compatibility

This product meets the requirements of the following EMC standards for electrical equipment for measurement, control, and laboratory use:

- EN 61326-1 (IEC 61326-1): Class A emissions; Basic immunity
- EN 55011 (CISPR 11): Group 1, Class A emissions
- EN 55022 (CISPR 22): Class A emissions
- EN 55024 (CISPR 24): Immunity
- AS/NZS CISPR 11: Group 1, Class A emissions
- AS/NZS CISPR 22: Class A emissions
- FCC 47 CFR Part 15B: Class A emissions
- ICES-001: Class A emissions



Note In the United States (per FCC 47 CFR), Class A equipment is intended for use in commercial, light-industrial, and heavy-industrial locations. In Europe, Canada, Australia, and New Zealand (per CISPR 11), Class A equipment is intended for use only in heavy-industrial locations.



Note Group 1 equipment (per CISPR 11) is any industrial, scientific, or medical equipment that does not intentionally generate radio frequency energy for the treatment of material or inspection/analysis purposes.



Note For EMC declarations, certifications, and additional information, refer to the [Product Certifications and Declarations](#) section.

Product Certifications and Declarations

Refer to the product Declaration of Conformity (DoC) for additional regulatory compliance information. To obtain product certifications and the DoC for NI products, visit ni.com/product-certifications, search by model number, and click the appropriate link.

Environmental Management

NI is committed to designing and manufacturing products in an environmentally responsible manner. NI recognizes that eliminating certain hazardous substances from our products is beneficial to the environment and to NI customers.

For additional environmental information, refer to the **Engineering a Healthy Planet** web page at ni.com/environment. This page contains the environmental regulations and directives with which NI complies, as well as other environmental information not included in this document.

EU and UK Customers

-  Waste Electrical and Electronic Equipment (WEEE)—At the end of the product life cycle, all NI products must be disposed of according to local laws and regulations. For more information about how to recycle NI products in your region, visit ni.com/environment/weee.

电子信息产品污染控制管理办法 (中国 RoHS)

-  中国 RoHS— NI 符合中国电子信息产品中限制使用某些有害物质指令(RoHS)。关于 NI 中国 RoHS 合规性信息，请登录 ni.com/environment/rohs_china。(For information about China RoHS compliance, go to ni.com/environment/rohs_china.)

¹ AC coupling available on 1 M Ω input only.

² Within ± 5 °C of self-calibration temperature.

³ For a 50 kHz signal with amplitude 90% of full-scale input range measured within ± 5 °C of self-calibration temperature.

⁴ Measured from one channel to another channel, with same range settings on both channels.

⁵ AC coupling available on 1 M Ω input only.

⁶ -1 dBFS input signal. Includes the second through the fifth harmonics. 24 MHz bandwidth filter enabled.

⁷ Verified using a 50 Ω terminator connected to input.

⁸ -1 dBFS input signal. Includes the second through the fifth harmonics. 24 MHz bandwidth filter enabled.

⁹ Verified using a 50 Ω terminator connected to input.

¹⁰ 10 MHz sine input signal.

¹¹ Internal Sample clock is locked to the Reference clock or derived from the onboard VCXO.

¹² You cannot export a decimated Sample clock signal.

13 Divide by **n** decimation used for all rates less than 60 MS/s. For more information about the Sample clock and decimation, refer to the [NI High-Speed Digitizers Help](#).

14 Divide by **n** decimation available where $1 \leq n \leq 65,535$. For more information about the Sample clock and decimation, refer to the [NI High-Speed Digitizers Help](#).

15 Default of 10 MHz. The PLL Reference clock frequency must be accurate to ± 50 ppm.

16 Holdoff set to 0. Onboard Sample clock at maximum rate.

17 Onboard memory is shared between all enabled channels.

18 Single-record and multirecord acquisitions.

19 The maximum number of records is 100,000.

20 Warm-up time begins after the NI-SCOPE driver is loaded. Unless manually disabled, the NI-SCOPE driver automatically loads with the operating system and enables the module.

21 Caused by clock and analog path delay differences. No manual adjustment performed.

22 For more information about manual adjustment, refer to the **Synchronization Repeatability Optimization** topic in the **NI-TClk Synchronization Help**.



Ihr Ansprechpartner /
Your Partner:

dataTec AG
E-Mail: info@datatec.eu
>>> www.datatec.eu

