

Macro lens 2.0x with case

P/N: T300238

Copyright

© 2023, FLIR Systems, Inc.

All rights reserved worldwide. Names and marks appearing herein are either registered trademarks or trademarks of FLIR Systems and/or its subsidiaries. All other trademarks, trade names or company names referenced herein are used for identification only and are the property of their respective owners.

Document identity

Publ. No.: T300238
 Commit: 71998
 Language: en-US
 Modified: 2020-11-19
 Formatted: 2023-11-01

Website

<http://www.flir.com>

Customer support

<http://support.flir.com>

Disclaimer

Specifications subject to change without further notice. Camera models and accessories subject to regional market considerations. License procedures may apply. Products described herein may be subject to US Export Regulations. Please refer to exportquestions@flir.com with any questions.



General description	
This Macro lens provides 2x magnification compared to the standard 24° lens in Macro mode. It is developed for R&D usage or development purposes, such as looking at PCB's or small electronic components.	
Imaging and optical data	
Field of view (FOV)	Depending on the IR resolution of the camera: <ul style="list-style-type: none"> • 320 x 240: 15.78 mm x 11.83 mm • 384 x 288: 15.78 mm x 11.83 mm • 464 x 348: 15.78 mm x 11.83 mm • 640 x 480: 15.36 mm x 11.52 mm
Magnifying factor	2.0x
Working distance	18 mm (0.71 in)
Depth of field	±0.1 mm
Focal length	17.5 mm (0.69 in)
Spatial resolution (IFOV)	Depending on the IR resolution of the camera: <ul style="list-style-type: none"> • 320 x 240 pixels: 49 µm/pixel • 384 x 288 pixels: 41 µm/pixel • 464 x 348 pixels: 34 µm/pixel • 640 x 480 pixels: 24 µm/pixel
Lens identification	Automatic
F-number	1.1
Number of lenses	4 (4 asph)
MTF @ 70% of FOV	For 30 cy/mm: 32%
Distortion	< 0.5%
Physical data	
Weight	0.19 kg (0.42 lb)
Size (L x D)	46 x 72 mm (1.8 x 2.83 in)
Front lens diameter	25.4 mm (1.0 in)
Shipping information	
Packaging, type	Cardboard box
List of contents	<ul style="list-style-type: none"> • Lens • Lens case • Front lens cap • Rear lens cap • Lens mounting instructions

Macro lens 2.0x with case

P/N: T300238

© 2023, FLIR Systems, Inc.

#T300238; r. 71998; en-US

Shipping information	
Packaging, weight	0.450 kg (0.99 lb)
Packaging, size	151 × 125 × 125 mm (5.9 × 4.9 × 4.9 in)
EAN-13	7332558025772
UPC-12	845188021481
Country of origin	Sweden

Compatible with the following products:

- 85900-0000; FLIR A700 Thermal Core
- 85900-1100; FLIR A700 Thermal Core, Optional temperature range
- 85902-0202; FLIR A700 24° Standard Science Kit
- 85903-0202; FLIR A700 24° f/1.0 Standard Science Kit
- 90600-0000; FLIR A500 Thermal Core
- 90600-1100; FLIR A500 Thermal Core, Optional temperature range
- 90610-0202; FLIR A500 24° Standard Science Kit
- 91900-0000; FLIR A400 Thermal Core
- 91900-1100; FLIR A400 Thermal Core, Optional temperature range
- 91902-0202; FLIR A400 24° Standard Science Kit
- 79301-0101; FLIR T530 14°
- 79302-0101; FLIR T530 24°
- 79304-0101; FLIR T530 24° + 14°
- 79306-0101; FLIR T530 24° + 14° & 42°
- 79305-0101; FLIR T530 24° + 42°
- 79303-0101; FLIR T530 42°
- 79307-0101; FLIR T530 42° + 14°
- 79301-0201; FLIR T540 14°
- 79302-0201; FLIR T540 24°
- 79304-0201; FLIR T540 24° + 14°
- 79306-0201; FLIR T540 24° + 14° & 42°
- 79305-0201; FLIR T540 24° + 42°
- 79303-0201; FLIR T540 42°
- 79307-0201; FLIR T540 42° + 14°
- 89001-0101; FLIR T560 14°
- 89002-0101; FLIR T560 24°
- 89004-0101; FLIR T560 24° + 14°
- 89006-0101; FLIR T560 24° + 14° & 42°
- 89005-0101; FLIR T560 24° + 42°
- 89003-0101; FLIR T560 42°
- 89007-0101; FLIR T560 42° + 14°
- 79309-0101; FLIR T530 80°
- 79309-0201; FLIR T540 80°
- 89010-0101; FLIR T560 80°
- 82501-0201; FLIR T840 14°
- 82502-0201; FLIR T840 24°
- 82504-0201; FLIR T840 24° + 14°
- 82506-0201; FLIR T840 24° + 14° & 42°
- 82509-0201; FLIR T840 24° + 14° & 6°
- 82505-0201; FLIR T840 24° + 42°
- 82508-0201; FLIR T840 24° + 6°
- 82503-0201; FLIR T840 42°
- 82507-0201; FLIR T840 42° + 14°
- 89201-0101; FLIR T860 14°
- 89202-0101; FLIR T860 24°
- 89204-0101; FLIR T860 24° + 14°
- 89206-0101; FLIR T860 24° + 14° & 42°
- 89211-0101; FLIR T860 24° + 14° & 6°
- 89205-0101; FLIR T860 24° + 42°



Mess- und Prüftechnik. Die Experten.

Ihr Ansprechpartner / **dataTec AG**
Your Partner: E-Mail: info@datatec.eu
datatec.eu



Macro lens 2.0x with case

P/N: T300238

© 2023, FLIR Systems, Inc.

#T300238; r. 71998; en-US

- 89210-0101; FLIR T860 24° + 6°
- 89203-0101; FLIR T860 42°
- 89207-0101; FLIR T860 42° + 14°
- 89201-0201; FLIR T865 14°
- 89202-0201; FLIR T865 24°
- 89204-0201; FLIR T865 24° + 14°
- 89206-0201; FLIR T865 24° + 14° & 42°
- 89213-0201; FLIR T865 24° + 14° & 6°
- 89205-0201; FLIR T865 24° + 42°
- 89212-0201; FLIR T865 24° + 6°
- 89203-0201; FLIR T865 42°
- 89207-0201; FLIR T865 42° + 14°
- 82511-0201; FLIR T840 80°
- 89215-0201; FLIR T865 80°

© 2016, FLIR Systems, Inc. All rights reserved worldwide. No part of this drawing may be reproduced, stored in a retrieval system, or transmitted in any form, or by any means, electronic, mechanical, photocopying, recording, or otherwise, without written permission from FLIR Systems, Inc. Specifications subject to change without further notice. Dimensional data is based on nominal values. Products may be subject to regional market considerations. License procedures may apply. Product may be subject to US Export Regulations. Please refer to exportquestions@flir.com with any questions. Diversion contrary to US law is prohibited.



Lens IR f=10mm (42°)

Lens IR f=17mm (24°)

Lens IR f=29mm (14°)

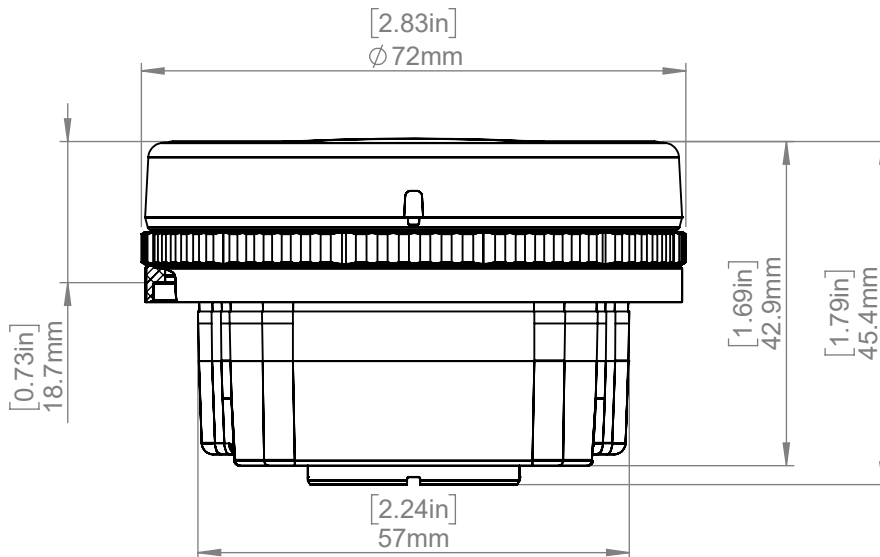
Lens IR Close-Up (2x) 



Modified 2019-09-30	Check JOHE	Drawn by R&D Instruments			
Denomination				Size A4	
Basic dimensions for lenses T199104, T199105, T199106, T199598			Scale 1:1		Sheet 1(1)
			Drawing No. T130322	Rev B	