

6514 Programmable Electrometer

DATASHEET



The 6514 Electrometer combines flexible interfacing capabilities with current sensitivity, charge measurement capabilities, resolution, and speed that are equal or superior to our earlier electrometers. The 6514's built-in IEEE-488, RS-232, and digital I/O interfaces make it simple to configure fully automated, high speed systems for low-level testing.

The 5½-digit 6514 is designed for applications that demand fast, yet precise measurements of low currents, voltages from high resistance sources, charges, or high resistances.

The 6514's exceptional measurement performance comes at an affordable price. While its cost is comparable with that of many high end DMMs, the 6514 offers far greater current sensitivity and significantly lower voltage burden (as low as 20 μ V) than other instruments can provide.

Key Features

- <1 fA noise
- >200 T Ω input impedance on voltage measurements
- Charge measurements from 10 fC to 20 μ C
- High speed—up to 1200 readings/second
- Interfaces readily with switches, computers, and component handlers
- Cancels voltage and current offsets easily

R&D on a Budget

The 6514 offers the flexibility and sensitivity needed for a wide array of experiments, providing better data far faster than older electrometer designs. Applications include measuring currents from light detectors and other sensors, beam experiments, and measuring resistances using a current source. In addition to use by researchers in areas such as physics, optics, and materials science, the affordable price of the 6514 makes it an attractive alternative to high end DMMs for low current measurement applications, such as testing resistance and leakage current in switches, relays, and other components. For more information on how the 6514 does this, refer to [Low Voltage Burden](#).

The 6514 builds on the features and capabilities of the Keithley electrometers that preceded it. For example, like those instruments, a built-in constant current source simplifies measuring resistance.

Two analog outputs—a 2 V output and a preamp output—are available for recording data with strip-chart recorders.



**Ihr Ansprechpartner /
Your Partner:**

dataTec AG
E-Mail: info@datatec.eu
datatec.eu

Economical Component Testing

Once, electrometers were simply considered too slow to keep up with the high throughput that production test applications demand. The 6514 is designed for fast, sensitive measurements, providing speeds up to 1200 readings per second with fast integration or 17 measurements per second with 60 Hz line-cycle integration. It offers 10 fA resolution on 2 nA signals, settling to within 10% of the final value in just 15 ms. A normal-mode rejection ratio (NMRR) of 60 dB allows making accurate low current measurements, even in the presence of line frequency induced currents, which is a common concern in production floor environments. The instrument's sensitivity makes it easy to determine the leakage resistance on capacitances up to 10 nF or even on higher capacitances when a series resistor is used.

While the 6514 can be easily operated manually using the front panel controls, it can also be externally controlled for automated test applications. Built-in IEEE-488 and RS-232 interfaces make it possible to program all instrument functions over the bus through a computer controller. The instrument's interfaces also simplify integrating external hardware, such as sources, switching systems, or other instruments, into the test system. A digital I/O interface can be used to link the 6514 to many popular component handlers for tight systems integration in binning, sorting, and similar applications.

These features make the 6514 a powerful, low cost tool for systems designed to test optical devices and leakage resistance on low-value capacitors, switches, and other devices, particularly when the test system already includes a voltage source or when the source current/measure voltage technique is used to determine resistance.

Low Voltage Burden

The 6514's feedback ammeter design minimizes voltage offsets in the input circuitry, which can affect current measurement accuracy. The instrument also allows active cancellation of its input voltage and current offsets, either manually via the front panel controls or over the bus with IEEE-488 commands.

Dark Current Measurements

When measuring dark currents (**Figure 1**) from a device such as a photodiode, the ammeter reads the sum of two different currents. The first current is the dark current (I_D) generated by the detector with no light falling upon the device (in other words, the signal of interest); the second one is the leakage current (I_L) generated by the voltage burden (V_{BURDEN}) appearing at the terminals of the ammeter. In a feedback ammeter, the primary "voltage burden" is the amplifier offset voltage. This leakage current represents an error current. Without the use of cancellation techniques, $I_L = V_{BURDEN}/R_L$. **Figure 2** illustrates how the 6514's CAL V_{OFFSET} is adjusted to cancel V_{BURDEN} to within the voltage noise level of a few microvolts, so the measured current is only the true dark current (I_D) of the photodiode. In a similar manner, offset currents can also be cancelled. Earlier electrometers used an internal numerical correction technique in which the voltage burden was still present, so the measured dark current included the error term $I_L = V_{BURDEN}/R_L$.

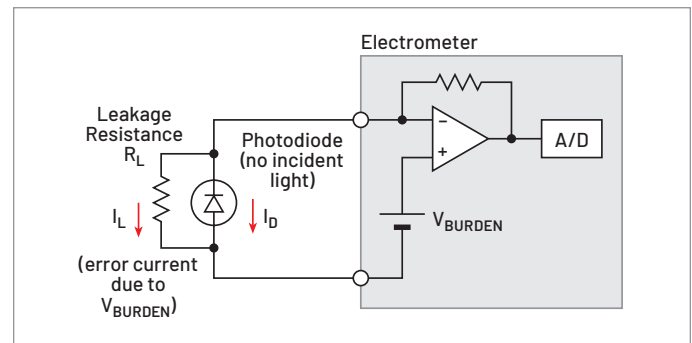

Figure 1. Dark Current Measurement with Burden Voltage Uncorrected

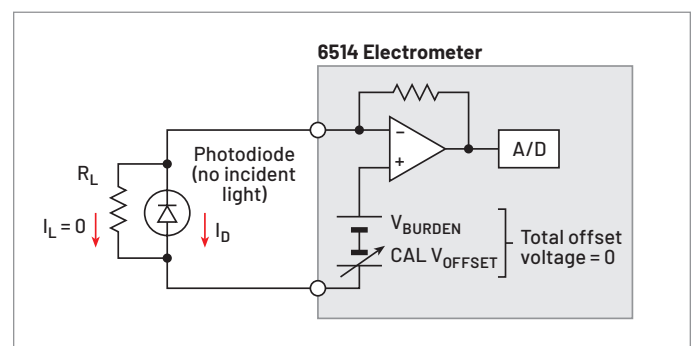

Figure 2. Dark Current Measurement with Burden Voltage Corrected

Voltage Burden and Measurement Error

Electrometers provide current measurement with lower terminal voltage than is possible when making DMM measurements. As shown in **Figure 3**, DMMs measure current using a shunt resistance that develops a voltage (typically 200 mV full-range) in the input circuit. This creates a terminal voltage (V_{BURDEN}) of about 200 mV, thereby lowering the measured current. Electrometers reduce this terminal voltage by using the feedback ammeter configuration illustrated in **Figure 1**. The 6514 lowers this terminal voltage still further—to the level of the voltage noise—by canceling out the small offset voltage that remains, as shown in **Figure 2**. Any error signals that remain are negligible in comparison to those that can occur when measuring current with a DMM.

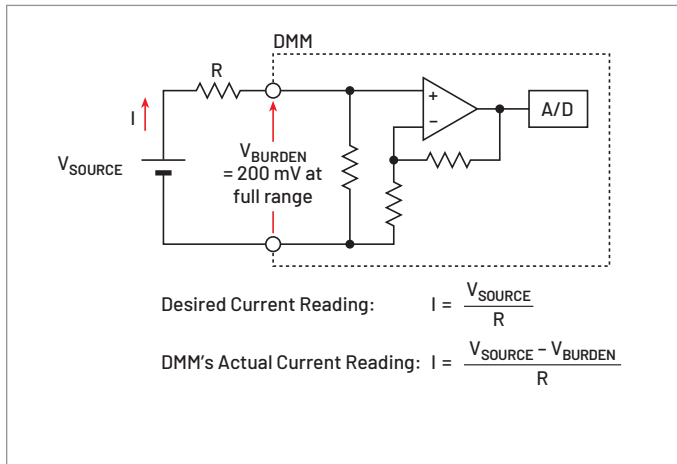

Figure 3. Errors Due to Burden Voltage when Measuring with a DMM

The example below compares a DMM's voltage burden errors with the 6514's.

If: $V_{SOURCE} = 1V, R = 50k\Omega$
 The desired current reading is: $I = \frac{1V}{50k\Omega} = 20\mu A$

Actual Reading (20 μA range on DMM): $V_{BURDEN} = 200mV$
 $I = \frac{1V - 200mV}{50k\Omega} = \frac{800mV}{50k\Omega} = 16\mu A$
 Refer to **Figure 3**. = 20% Burden error with a DMM

6514 Actual Reading: $V_{BURDEN} = 10\mu V$
 $I = \frac{0.999990V}{50k\Omega} = 19.9998\mu A$
 Refer to **Figure 2**. = 0.001% Burden error with the 6514

DMM Offset Currents

Typically, offset currents in DMMs are tens or hundreds of picoamps, which severely limits their low current measuring capabilities compared to the 6514 with 3 fA input bias current.

APPLICATIONS

- High resistivity measurements
- Leakage currents
- Ion selective electrode measurements
- pH measurements
- Conductivity cells
- Potentiometry

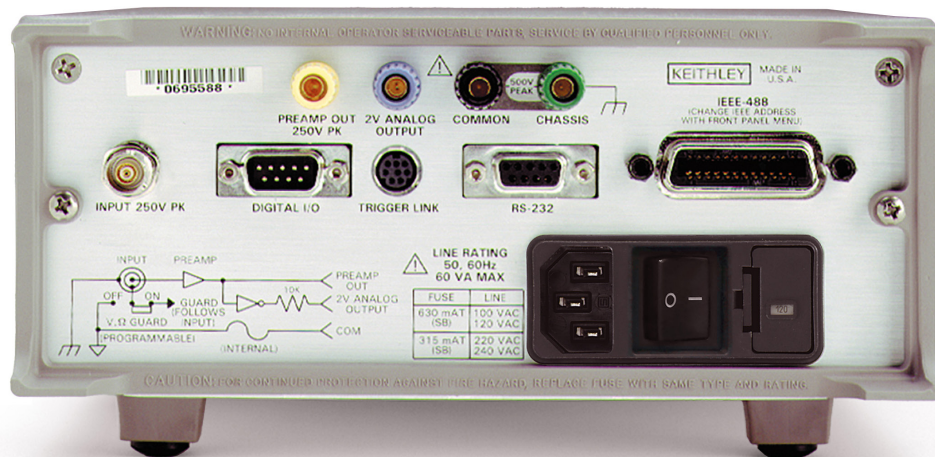

Specifications

Volts

Range	5½-Digit Resolution	Accuracy (1 Year) ¹ 18° to 28°C ±(%rdg+counts)	Temperature Coefficient 0° to 18°C & 28° to 50°C ±(%rdg+counts)/°C
2 V	10 µV	0.025 + 4	0.003 + 2
20 V	100 µV	0.025 + 3	0.002 + 1
200 V	1 mV	0.06 + 3	0.002 + 1

Notes

1. When properly zeroed, 5½-digit. Rate: Slow(100 ms integration time).

NMRR 60 dB on 2 V, 20 V, >55 dB on 200 V, at 50 Hz or 60 Hz ±0.1%.

CMRR >120 dB at DC, 50 Hz or 60 Hz.

Input Impedance >200 TΩ in parallel with 20 pF, <2 pF guarded (10 MΩ with zero check on).

Small Signal Bandwidth at Preamp Output

Typically 100 kHz (-3 dB).

Amps

Range	5½-Digit Resolution	Accuracy (1 Year) ² 18° to 28°C ±(%rdg+counts)	Temperature Coefficient 0° to 18°C & 28° to 50°C ±(%rdg+counts)/°C
20 pA	100 aA ³	1 + 30	0.1 + 5
200 pA	1 fA ³	1 + 5	0.1 + 1
2 nA	10 fA	0.2 + 30	0.1 + 2
20 nA	100 fA	0.2 + 5	0.03 + 1
200 nA	1 pA	0.2 + 5	0.03 + 1
2 µA	10 pA	0.1 + 10	0.005 + 2
20 µA	100 pA	0.1 + 5	0.005 + 1
200 µA	1 nA	0.1 + 5	0.005 + 1
2 mA	10 nA	0.1 + 10	0.008 + 2
20 mA	100 nA	0.1 + 5	0.008 + 1

Notes

2. When properly zeroed, 5½-digit. Rate: Slow(100 ms integration time).

3. aA=10⁻¹⁸A, fA=10⁻¹⁵A.

Input Bias Current <3 fA at T_{cal} (user adjustable). Temperature coefficient = 0.5 fA/°C.

Input Bias Current Noise <750 aA p-p (capped input), 0.1 Hz to 10 Hz bandwidth, damping on. Digital filter = 40 readings.

Input Voltage Burden at T_{cal} ±1°C (user adjustable)

<20 µV on 20 pA, 2 nA, 20 nA, 2 µA, 20 µA ranges.

<100 µV on 200 pA, 200 nA, 200 µA ranges.

<2 mV on 2 mA range.

<4 mV on 20 mA range.

Temperature Coefficient of Input Voltage Burden

<10 µV/°C on pA, nA, µA ranges.

Preamp Settling Time (to 10% of final value)

2.5 s typical on pA ranges, damping off, 3 s typical on pA ranges damping on, 15 ms on nA ranges, 5 ms on µA and mA ranges.

NMRR >95 dB on pA, 60 dB on nA, µA, and mA ranges at 50 Hz or 60 Hz ±0.1%. Digital Filter = 40.

Ohms

Range	5½-Digit Resolution	Accuracy (1 Year) ⁴ 18° to 28°C ±(%rdg+counts)	Temperature Coefficient 0° to 18°C & 28° to 50°C ±(%rdg+counts)/°C	Test Current (nominal)
2 kΩ	10 mΩ	0.20 + 10	0.01 + 2	0.9 mA
20 kΩ	100 mΩ	0.15 + 3	0.01 + 1	0.9 mA
200 kΩ	1 Ω	0.25 + 3	0.01 + 1	0.9 mA
2 MΩ	10 Ω	0.25 + 4	0.02 + 2	0.9 μA
20 MΩ	100 Ω	0.25 + 3	0.02 + 1	0.9 μA
200 MΩ	1 kΩ	0.30 + 3	0.02 + 1	0.9 μA
2 GΩ	10 kΩ	1.5 + 4	0.04 + 2	0.9 nA
20 GΩ	100 kΩ	1.5 + 3	0.04 + 1	0.9 nA
200 GΩ	1 MΩ	1.5 + 3	0.04 + 1	0.9 nA

Notes

4. When properly zeroed, 5½-digit. Rate: Slow (100 ms integration time).

Maximum Open Circuit Voltage 250 V DC.

Preamp Settling Time (To 10% of final reading with <100 pF input capacitance)

2 kΩ through 200 kΩ: 2 ms.

20 MΩ through 200 MΩ: 90 ms.

2 GΩ through 200 GΩ: 1 s.

Coulombs

Range	6½-Digit Resolution	Accuracy (1 Year) ^{5,6} 18° to 28°C ±(%rdg+counts)	Temperature Coefficient 0° to 18°C & 28° to 50°C ±(%rdg+counts)/°C
20 nC	10 fC	0.4 + 50	0.04 + 10
200 nC	100 fC	0.4 + 50	0.04 + 10
2 μC	1 pC	1 + 50	0.05 + 10
20 μC	10 pC	1 + 50	0.05 + 10

Notes

5. Charge acquisition time must be <1000 s, derate 2% for each additional 10,000 s.

6. When properly zeroed, 6½-digit. Rate: Slow (100 ms integration time).

INPUT BIAS CURRENT <4 fA at T_{cal}. Temperature coefficient = 0.5 fA/°C.

IEEE-488 Bus Implementation

Multiline Commands DCL, LLO, SDC, GET, GTL, UNT, UNL, SPE, SPD.

Implementation SCPI (IEEE-488.2, SCPI-1996.0); DDC (IEEE-488.1).

Uniline Commands IFC, REN, EOI, SRQ, ATN.

Interface Functions SH1, AH1, T5, TE0, L4, LE0, SR1, RL1, PP0, DC1, DT1, C0, E1.

Programmable Parameters Function, Range, Zero Check, Zero Correct, EOI (DDC mode only), Trigger, Terminator (DDC mode only), Data Storage 2500 Storage, Calibration (SCPI mode only), Display Format, SRQ, REL, Output Format, Guard, V-offset Cal, I-offset Cal.

Address Modes TALK ONLY and ADDRESSABLE.

Language Emulation 6512, 617, 617-HIQ emulation via DDC mode.

Trigger to Reading Done 150 ms typical, with external trigger.

RS-232 Implementation

Supports: SCPI 1996.0.

Baud Rates: 300, 600, 1200, 2400, 4800, 9600, 19.2 k, 38.4 k, 57.6 k.

Protocols: Xon/Xoff, 7 or 8 bit ASCII, parity-odd/even/none.

Connector: DB-9 TXD/RXD/GND.

General

Overrange Indication	Display reads "OVRFLOW."
Ranging	Automatic or manual.
Conversion Time	Selectable 0.01 PLC to 10 PLC.
Programs	Provide front panel access to IEEE address, choice of engineering units or scientific notation, and digital calibration.
Maximum Input	250 V peak, DC to 60 Hz sine wave; 10 s per minute maximum on mA ranges.
Maximum Common Mode Voltage (DC to 60 Hz Sine Wave)	Electrometer, 500 V peak.
Isolation (Meter Common to Chassis)	Typically $10^{10} \Omega$ in parallel with 500 pF.
Input Connector	Three lug triaxial on rear panel.
2 V Analog Output	2 V for full range input. Inverting in Amps and Coulombs mode. Output impedance 10 k Ω .
Preamp Output	Provides a guard output for Volts measurements. Can be used as an inverting output or with external feedback in Amps and Coulombs modes.
Digital Interface	Handler Interface: Start of test, end of test, 3 category bits. Digital I/O: 1 Trigger input, 4 outputs with 500 mA sink capability. Connector: 9 pin D subminiature, male pins.
EMC	Conforms with European Union Directive 89/336/EEC EN55011, EN50082-1, EN61000-3-2, EN61000-3-3, FCC part 15 class B.
Safety	Conforms with European Union Directive 73/23/EEC EN61010-1.
Guard	Switchable voltage and ohm guard available.
Trigger Line	Available, see manual for usage.
Reading Storage	2500 readings.
Reading Rate	To Internal Buffer: 1200 readings/second (0.01 PLC, Digital Filters Off, Front Panel Off, Auto Zero Off). To IEEE-488 Bus: 500 readings/second (0.01 PLC, Digital Filters Off, Front Panel Off, Auto Zero Off; Binary Transfer Mode). To Front Panel: 17 readings/second at 60 Hz (1.00 PLC, Digital Filters Off); 15 readings/second at 50 Hz (1.00 PLC, Digital Filters Off).
Digital Filter	Median and averaging (selectable from 2 to 100 readings).
Damping	User selectable on Amps function.
Environment	Operating: 0°–50°C; relative humidity 70% non-condensing, up to 35°C. Storage: -25° to +65°C.
Warm-Up	1 hour to rated accuracy (see manual for recommended procedure).
Power	90–125 V or 210–250 V, 50–60 Hz, 60 VA.
Physical	Case Dimensions: 90 mm high \times 214 mm wide \times 369 mm deep (3½ in. \times 8⅜ in. \times 14⅞ in.). Working Dimensions: From front of case to rear including power cord and IEEE-488 connector: 15.5 inches. Net Weight: <4.6 kg (<10.1 lbs). Shipping Weight: <9.5 kg (<21 lbs).

Ordering Information

6514	Programmable Electrometer
------	---------------------------

Supplied Accessories

237-ALG-2	Low Noise Triax Cable, 3-Slot Triax to Alligator Clips, 2 m (6.6 ft)
-----------	--

Available Accessories

Cables

237-ALG-2	Low Noise Triax Cable, 3-Slot Triax to Alligator Clips, 2 m (6.6 ft)
7007-1	Shielded IEEE-488 Cable, 1 m (3.3 ft)
7078-TRX-3	Low Noise Triax Cable, 3-Slot Triax Connectors, 0.9 m (3 ft)
7078-TRX-10	Low Noise Triax Cable, 3-Slot Triax Connectors, 3 m (10 ft)
7078-TRX-20	Low Noise Triax Cable, 3-Slot Triax Connectors, 6 m (20 ft)
8501-1	Trigger-Link Cable, 1 m (3.3 ft)

Rack mount kits

4288-1	Single Fixed Rack Mounting Kit
4288-2	Dual Fixed Rack Mounting Kit

Adapters

7078-TRX-BNC	3-Lug Triax to BNC Adapter
237-TRX-T	3-Slot Male Triax to Dual 3-Lug Female Triax Tee Adapter
237-TRX-TBC	3-Lug Female Triax Bulkhead Connector (1.1 kV rated)
7078-TRX-TBC	3-Lug Female Triax Bulkhead Connector with Cap

GPIB Interfaces

KPCI-488LPA	IEEE-488 Interface/Controller for the PCI Bus
KUSB-488B	IEEE-488 USB-to-GPIB Interface Adapter

Services Available

6514-3Y-EW	1-year factory warranty extended to 3 years from date of shipment
C/6514-3Y-ISO	3 (ISO-17025 accredited) calibrations within 3 years of purchase (not available in all countries)
TRN-LLM-1-C	Course: Making Accurate Low-Level Measurements

Contact Information:

Australia 1 800 709 465
Austria* 00800 2255 4835
Balkans, Israel, South Africa and other ISE Countries +41 52 675 3777
Belgium* 00800 2255 4835
Brazil +55 (11) 3530-8901
Canada 1 800 833 9200
Central East Europe / Baltics +41 52 675 3777
Central Europe / Greece +41 52 675 3777
Denmark +45 80 88 1401
Finland +41 52 675 3777
France* 00800 2255 4835
Germany* 00800 2255 4835
Hong Kong 400 820 5835
India 000 800 650 1835
Indonesia 007 803 601 5249
Italy 00800 2255 4835
Japan 81(3) 6714 3086
Luxembourg +41 52 675 3777
Malaysia 1 800 22 55835
Mexico, Central/South America and Caribbean 52 (55) 88 69 35 25
Middle East, Asia, and North Africa +41 52 675 3777
The Netherlands* 00800 2255 4835
New Zealand 0800 800 238
Norway 800 16098
People's Republic of China 400 820 5835
Philippines 1 800 1601 0077
Poland +41 52 675 3777
Portugal 80 08 12370
Republic of Korea +82 2 565 1455
Russia / CIS +7 (495) 6647564
Singapore 800 6011 473
South Africa +41 52 675 3777
Spain* 00800 2255 4835
Sweden* 00800 2255 4835
Switzerland* 00800 2255 4835
Taiwan 886 (2) 2656 6688
Thailand 1 800 011 931
United Kingdom / Ireland* 00800 2255 4835
USA 1 800 833 9200
Vietnam 12060128

* European toll-free number. If not accessible, call: +41 52 675 3777

Rev. 02.2022



**Ihr Ansprechpartner /
Your Partner:**

dataTec AG
E-Mail: info@datatec.eu
datatec.eu

Mess- und Prüftechnik. Die Experten.

Find more valuable resources at TEK.COM

Copyright © Tektronix. All rights reserved. Tektronix products are covered by U.S. and foreign patents, issued and pending. Information in this publication supersedes that in all previously published material. Specification and price change privileges reserved. TEKTRONIX and TEK are registered trademarks of Tektronix, Inc. All other trade names referenced are the service marks, trademarks or registered trademarks of their respective companies.
060226 KEI 1KW-74266-1

