

Modular Solar Array Simulators Migration Guide

From E4360 to MP4300 Series

Introduction

The Keysight MP4300 is the next generation of Modular Solar Array Simulator (SAS) for users of the Keysight E4360A. The MP4300 design provides higher performance and greater flexibility while maintaining compatibility with the E4360A.



Mess- und Prüftechnik. Die Experten.

Ihr Ansprechpartner /
Your Partner:

dataTec AG
E-Mail: info@datatec.eu
>>> www.datatec.eu

 **KEYSIGHT**
Authorized Premium
Distributor

Overview

The MP4300 SAS stands out as a powerful and compact upgrade to the Keysight Technologies E4360A Modular Solar Array Simulator (SAS), which was designed to provide up to 1200W of power to various instruments. Offering an impressive 6000W of power across 6 channels, the MP4300 SAS is an ideal substitute for its predecessor, boasting increased power capacity and enhanced bench-friendly capabilities. This document is tailored for pre-existing E4360A SAS users seeking a power supply with a larger power range and new customers searching for a suitable Modular SAS mainframe. As a comparison guide, it emphasizes the substantial benefits that the MP4300 SAS brings to the table.

This document comprehensively compares the specifications and capabilities of the E4360A and MP4300 SAS mainframes and their respective modules. It also provides insights into the performance of both simulators within specific, real-world applications. To maximize this guide's benefits, use it in conjunction with the referenced external documents throughout its content. Please note that this document does not replace any manuals, and it is strongly recommended to have copies of all the relevant documentation on hand for easy reference while reading this comprehensive comparison.

Model selection guide

E4360A is a module-based solar array simulator consisting of the mainframe (E4360A) and 2 modules (E4361A and E4362A). Up to 2 output modules can be installed in each Keysight E4360A mainframe.

The following tables detail the module combinations that most accurately replace the existing E4360A counterpart.

I own a Keysight...

E4360A Modular Solar Array Simulator Mainframe, 1200 W.
E4361A Solar Array Simulator DC Module 65 V, 8.5 A, 510 W
E4362A Solar Array Simulator DC Module 130 V, 5 A, 600 W

My model can be replaced with a Keysight...

-
- MP4301A Modular Power System 6kW Mainframe (200/208Vac)
 - MP4302A Modular Power System 6kW Mainframe (380/400/480Vac)
 - MP4361A - Solar Array Simulator Auto Ranging 0-160V, 0-10A, 1kW
 - MP4362A - Solar Array Simulator Module 0-130V, 0-8A, 1kW
-

Key product comparison

MP4300A and E4360A modular SAS

Item	New MP4300A	E4360A
Available option	MP4301A 6000 W Modular SAS; 200-208 VAC MP4302A 6000 W Modular SAS; 380-480 VAC	E4360A 1200 W Modular SAS
Power	Up to 6000 W with six modules installed	Up to 1200 W with two modules installed
No. of Outputs	6	2
Sinking Capability	10A (MP4361A), 500mA (MP4362A)	500mA
AC input	200-208 VAC nominal, 3-phase or 380-480 VAC nominal, 3-phase	100, 120, 220, 240 VAC nominal Universal input; no switch setting At 100/120 VAC nominal, max current is derated by half
Dimensions	2 U for 6 outputs	2 U for 2 outputs
Analog Input	No	Yes
Hardware Trigger	Not Available	Digital I/O trigger to the mainframe for synchronized curve switching and measurements
I-V Curve switching speed	<30msec	<30msec on up to 100 outputs in Fast Mode <250msec on up to 100 outputs in High resolution
V & I measurement speed	<500msec	<500msec on up to 100 outputs
Datalogging	No	Yes
Curve mode	Yes	Yes
Table mode	Yes	Yes
Curve List Mode	No	Up to 512 curves
Diode Terminal	Must be enabled programmatically - coming soon	Connects internal diode in series with +output
Auto parallel	(Not Available) Coming Soon	2 modules can be connected in parallel. and programmed as one (1.2kW)
Output couple control	No	Yes
System software driver	IVI (Coming Soon)	IVI, 14360A
Bus speed	< 1ms	1ms
Rack mounting	Standard support rails and ears	Custom rack mount kit
Weight	29.5 kg with six modules installed	18.6 kg with two modules installed
Power dissipation (for 6 outputs)	1164W (1 mainframe + 6 modules)	3800W (3 mainframes + 6 modules)
Power cord	Supplied by customer	Supplied with mainframe

Key product comparison (continued)

MP4300A and E4360A modular SAS

Item	New MP4300A	E4360A
Interfaces	GPIB (optional), LAN, USB, USB-C, built-in Web server	GPIB, LAN, USB, built-in Web server
Output ratings	6 outputs; up to 1 kW per output 10 A or 8 A (module dependent)	2 outputs; up to 600 W per output 8.5 A or 5 A (module dependent)
Module installation	Modules install through the back of the mainframe. After installation, the lockout bar must be installed.	Modules install through the top of the mainframe after first removing the blower cover.
Front panel controls	Minimal front panel buttons High-resolution display with built-in touch controls	Individual keys for main functions Extensive menu controls
+/- Output & sense connections	Part of a 4-pin connector including +s, -s Side tabs lock the connector into place	Part of a 5-pin connector including +s, -s, +D Has no locking mechanism

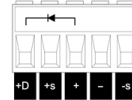
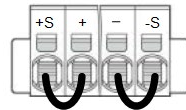
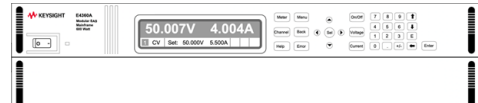
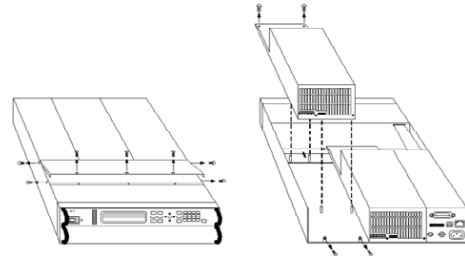

Mainframe Comparisons

Programming and interfacing

Controlling the front panel – E4360A

The front panel of the E4360A contains the standard keys for recent Keysight instruments; An On/Off switch, four groups of keys for controlling the instrument, and a 2-inch display screen for viewing responses to key instructions.

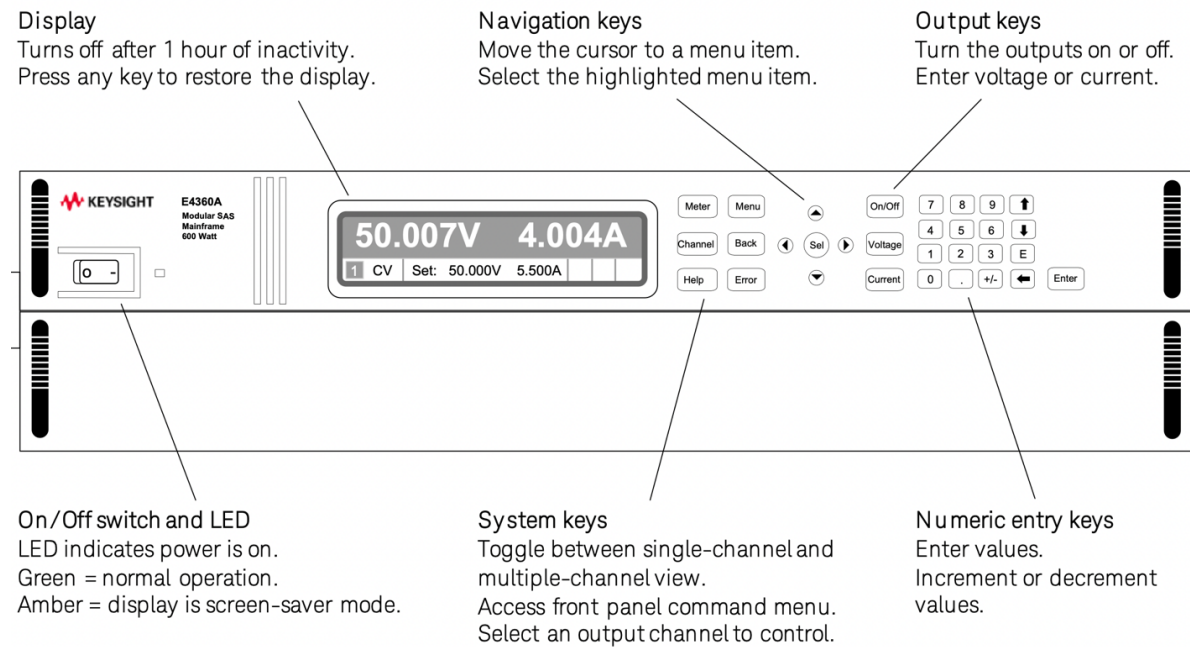

Figure 1. The front panel of E4360A

Controlling the front panel – MP4300

As a trend in newer Keysight products, a touch interface has been integrated into the front panel of the MP4300. Most of the front panel keys from earlier instruments have been substituted for solely function keys and touch-to-access features on the front panel. A Knob turner has also been included for scrolling through display sections and entering values.

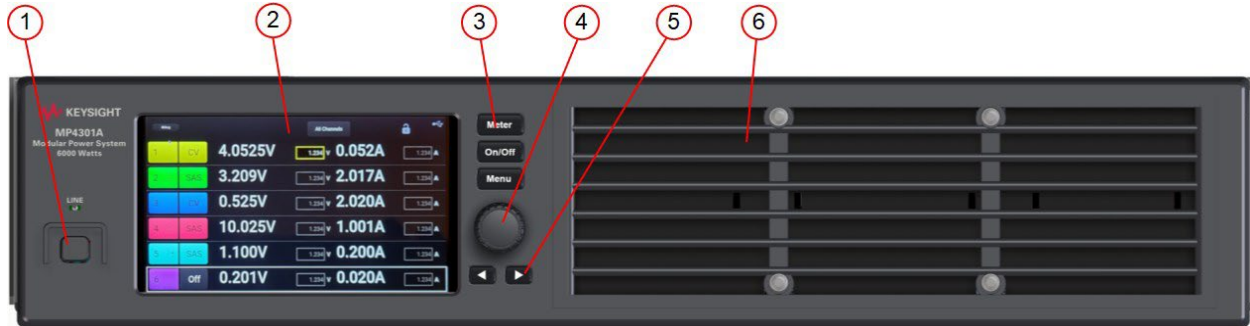

Figure 2. The front panel of MP4300

Labels	Items	Descriptions / Remarks
1	On/Off switch	Push this switch to turn the instrument on or off
2	Display	Automatically turns off after 1 hour of inactivity. Touch the display to restore it
3	Function keys	Switching between metering, mode, and command functions
4	RPG	Scrolls through the display selections
5	Navigation keys	Move horizontally across the sections on the display
6	Air inlets	Do not block front panel air inlets

By tapping the numbers to the left of the display screen, users can access additional delays on individual channels and make desired changes to them.

Controlling the rear panel – E4360A

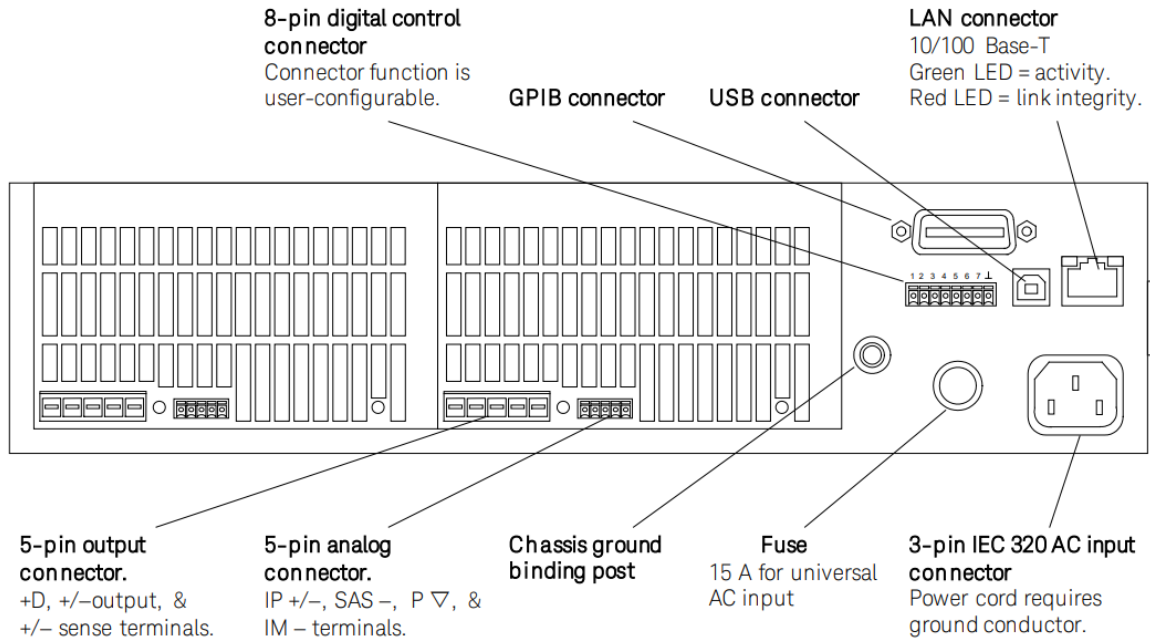

Figure 3. Diagram and airflow for the E4360A mainframe

Controlling the rear panel – MP4300

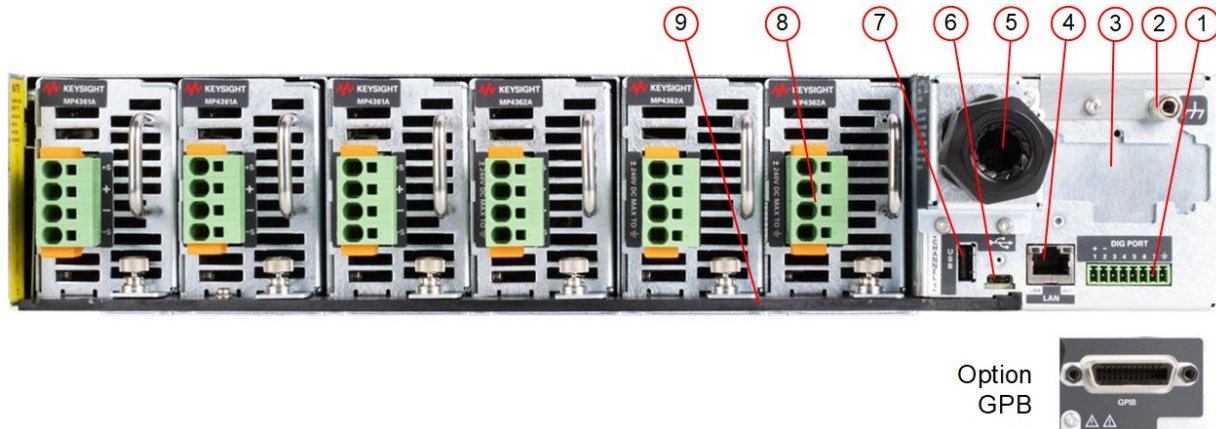

Figure 4. Diagram and airflow for the MP4300 mainframe

Labels	Items	Descriptions / Remarks
1	Digital I/O	Digital I/O connector. Pins are user configurable.
2	Auxiliary chassis ground stud	Not for use with AC mains connections
3	Option cover	Location reserved for optional GPB
4	LAN	LAN 10/100/1000 Base-T. The left LED indicates activity and the right LED indicates link integrity.
5	AC input cover	AC input requires 3-phase L1, L2, and L3 connections. A chassis ground stud is located under the cover for the AC mains ground connections. The AC input is bi-directional.
6	USB-C	USB-C interface connector. A USB-C with a locking connection is recommended.
7	Memory port	Reserved for future use.
8	Module connectors	Includes sense and output connections for each power module. Up to six single-slot modules can be installed in an MPS mainframe.
9	Lockout bar	Must be installed to operate power modules

Operating modes

E4360A

SAS mode:

In this mode, an I-V curve is generated using four input parameters:

- V_{OC} - open circuit voltage
- I_{SC} - short circuit current
- I_{MP} - current at maximum power
- V_{MP} - voltage at maximum power

Table mode:

In this mode, the SAS plots a given set of I-V points to specify the power curve.

- Up to 60 tables are provided for a product—with a maximum of 4000 points for each table.
- Up to 30 tables can be created and stored in volatile memory per mainframe.
- Up to 30 tables can be stored in non-volatile memory per mainframe

Fixed mode:

The mainframe behaves like a rectangular power supply with low output capacitance and high-speed constant current characteristics. This is the default mode and is used in instrument calibration and verification

MP4300 series

Compensation modes are available for different applications to achieve optimal performance. Users must select compensation mode (Default mode, DCDC_20UF Mode, SHUNTSW Mode) in SAS mode and Table mode.

SAS mode (Curve mode):

The MP4360 SAS internally generates an I-V curve using four input parameters.

- V_{OC} - open circuit voltage
- I_{SC} - short circuit current
- I_{MP} - current at the peak power point on the curve
- V_{MP} - voltage at the peak power point on the curve

Table mode:

A user-defined table of points determines the I-V curve.

- A table can have a minimum of 3 points up to a maximum of 1024 points.
- The I-V curve is determined by interpolating a user-defined table of points.
- Up to 30 tables can be created and stored in volatile memory per mainframe.
- Up to 30 tables can be stored in non-volatile memory per mainframe

Fixed mode:

This is the default mode when the unit is powered on. The MP4362A has the rectangular I-V characteristics of a standard power supply, and the MP4361A output characteristic is auto-ranging. In this operation power supply can be configured to source or sink current. Users need to select either voltage priority or current priority operating mode.

SCPI Commands

Subsystem commands

All subsystem commands from the E4360A remain present in the MP4300 SAS. Some commands have been added to the latter for extended functions:

- In the [SOURce:] command, a FUNCTION keyword has been integrated. This command is used to set voltage or current priority. Note that the user must first specify the operating mode to access this command—as this command only applies in fixed mode.
- A HCOPY subsystem command has been added to the MP4300 SAS. HCOPY commands return the display image on the MP4300 front panel as well as the format (BMP, JPG, PNG)
- An LXI subsystem has also been added. The LXI:IDENTify[:STATe] 0/1 command is used to turn the LXI indicator on the front panel of the MP4300 on or off

The LIST mode in Montu is not available in GO.

The difference in SCPI command when operating in Table mode

Operations	E4360A	MP4360A
Creates a new table in volatile memory	mem:tabl:sel curve1	MEM:TABL:SEL "curve1"
Program the table	MEM:TABL:VOLT 0,5,10,50,55 MEM:TABL:CURR 4,4,3.5,2,0	MEM:TABL:VOLT 0,5,10,50,55 MEM:TABL:CURR 4,4,3.5,2,0
Copy table to nonvolatile memory	MEM:COPY:TABL curve1	MEM:COPY:TABL "curve1"
Select a table on output 1	CURR:TABL:NAME curve1,(@1)	CURR:TABL:NAME "curve1",(@1)
Enable Table Mode	CURR:MODE TABL,(@1)	CURR:MODE TABL,(@1)
Specify the compensation in SAS Mode (Only applicable in MP4360A)		CURR:SAS:BWID "SHUNTSW", (@1)
Output the Table	OUTP ON,(@1)	OUTP ON,(@1)

The difference in SCPI command when operating in SAS mode

Operations	E4360A	MP4360A
Specify the tables in points	Curr:mode:dtab 256 4096, (@1)	only 1024 points
Enable SAS mode	CURR:MODE SAS, (@1)	CURR:MODE SAS, (@1)
Program the Curve	curr:sas:ISC 5,(@1); IMP 4.5, (@1); :VOLT:SAS:VOC 100, (@1); VMP 90, (@1)	curr:sas:ISC 5,(@1); IMP 4.5, (@1); :VOLT:SAS:VOC 100, (@1); VMP 90, (@1)
Specify the compensation in SAS Mode (Only applicable in MP4360A)		CURR:SAS:BWID " SHUNTSW", (@1)
To run the curve on output 1	OUTP ON,(@1)	OUTP ON,(@1)

The difference in SCPI command when operating in Fixed mode

Operations	E4360A	MP4360A
Enable Fixed mode	Curr:mode fixed, (@1)	Curr:mode fixed, (@1)
Set Voltage and Current	Curr 5, (@1) Volt 10, (@1)	
Set the output regulation – voltage/current priority mode (Only applicable in MP4360A)		Func Curr Volt, (@1)
Set the output when in voltage priority mode (Only applicable in MP4360A)		volt 10, (@1) curr:lim 5, (@1)
Set the output when in current priority mode (Only applicable in MP4360A)		Func Curr Volt, (@1) curr 5, (@1) volt:lim 10, (@1)
Enable Output	Output ON, (@1)	Output ON, (@1)

AC input

E4360A

Has a universal input mainframe—meaning that the modules can operate in any range between 100 VAC—240 VAC

An AC mains power cable is provided with the unit.

Note: The E4360A mainframe cannot operate at full power when supplied by standard 100-120 VAC circuits. In this case, the available power of the mainframe will be limited to 600W, while the current drawn will be less than—so that the 100-120 VAC circuits will not be overloaded.

Power consumption:

- 1440 VA (@ <, 180 VAC input for E4360A)
- 2500 VA (@ >, 180 VAC input for E4360A)
- 1440 VA (@100 VAC – 240 VAC input for E4360J01)

MP4301A/MP4302A

Operate at three-phase power inputs; the MP4301A operates at 200-208 VAC, and the MP4302A operates between 400-480 VAC.

An AC mains power cable is not provided with the unit.

Refer to the following table for each cable conductor's maximum current capacity requirements.

Model	Power cord recommendation	Max input current Phase L1, L2 and L3
MP4301A	10/4 SJOOW Cord 300 V UL/CSA	23.1 A
MP4302A	12/4 SOOW Cord 600 V UL/CSA	12.2 A

Digital connectors

Both the E4360A and MP4300 contain 8-pin digital connectors on the rear of the mainframe. Digital pins are user-configurable, with each pin having one or more control functions for the mainframe. In addition, the polarity of each pin can also be configured as positive or negative.

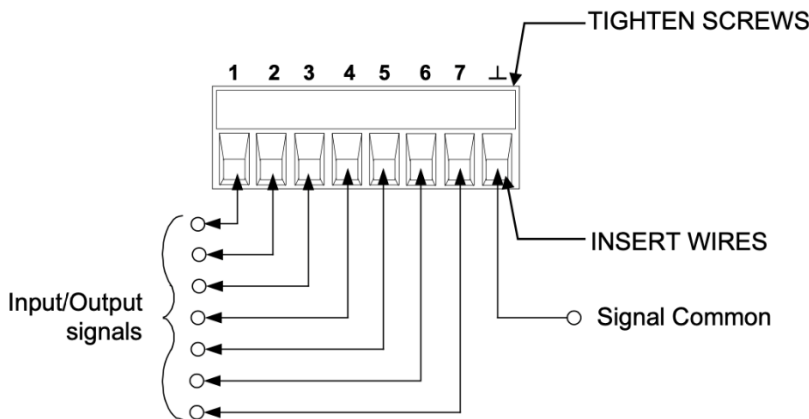

Figure 5. E4360A and MP4300 Digital connectors

See the E4360A and MP4300 user manuals for extensive detail on programming the digital pins for specific functions. The specifications in Appendix A also contain detailed function assignments to different pins.

Output couple control

E4360A

Output coupling lets you connect multiple instruments together and synchronize their output on/off sequence.

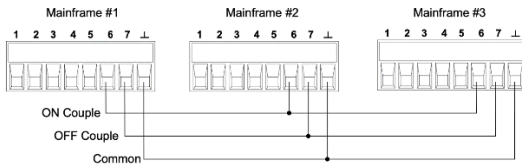

MP4300

Output couple control is not available in MP4300

Module installation

E4360A

Modules are installed from the top of the mainframe box—with additional screws to secure fastening

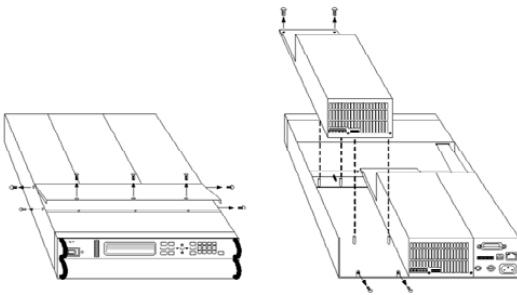

MP4300

In the MP4300, the modules are inserted through the rear of the mainframe via a slide-in mechanism. A lockout bar is then installed at the rear to secure the modules during operation. The modules cannot be accessed via the front panel if the lockout bar is not implemented. Refer to the user guides for more information on power module installation. (Appendix A)

Installing modules in the MP4300 simplifies the process for customers, allowing them to install without opening the mainframe box, thereby enhancing convenience.

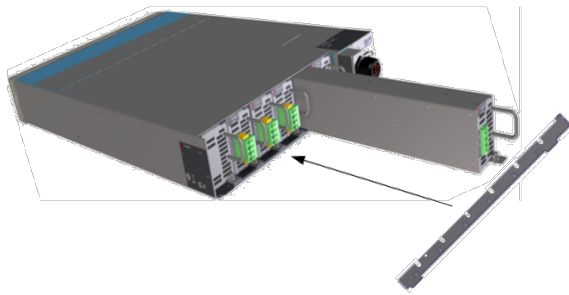

Rack mounting and airflow

E4360A

Mounted on a standard 19-inch rack panel or cabinet

Airflow in the E4360A runs across the sides of the mainframe

Recommend placing 1U of space between E4360A mainframes to aid airflow

Must order Opt 908 Rack Mount Kit for rack mounting

MP4300

Mounted on a standard 19-inch rack panel or cabinet. It must be installed into the mainframe before mounting.

CAUTION: Do not block the air intake and exhaust of the MP4300.

An air inlet has been integrated at the front of the MP4300 SAS, and airflow runs from the front to the back of the mainframes through the exhaust. The airflow in both instruments can be compared in Appendix B.

Multiple MP4300 mainframes can easily be stacked on top of each other without the concern of overheating

Keysight 1CP104A Rack mount kit with handles - for use with MP4301A and MP4302A.

Keysight RP7908A Rack rails for Keysight racks or similar designs

Modules size and density

E4360A

- 2U in height.
- The E4360A is designed to contain, at most, two wide-range modules

MP4300A

- 2U in height.
- The MP4300 has a slightly smaller width of 16.89 inches—compared to the E4360A at 17.03 inches.
- The MP4300 has a much larger channel set—one mainframe can contain six single-wide modules.



Module Comparisons

Output connectors

E4360A

- Part of a 5-pin connector including +s, -s, +D.
- Has no locking mechanism

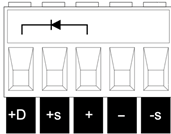

E4360A modules have a built-in reverse-current blocking diode. This diode protects the instrument from reverse currents that can be generated if a paralleled output or a battery is connected to the output and its over-voltage protection trips. The +D is optional to use in events where reverse currents higher than the output rating may be generated; In these cases, the +D serves as the positive terminal – not the actual +output terminal. Remote and local sensing is carried out similarly for both modules.

MP4300

- Part of a 4-pin connector including +s, -s.
- Side tabs lock the connector into place

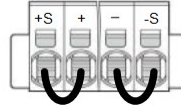

The MP4300 has four output terminals rather than 5 incorporated in the rear of the modules. In place of a diode terminal, the reverse-current blocking diode is internally switched on using the [OUTP:MODE DIO, (@1)] SCPI command.

Analog connectors

E4360A

Analog connectors are included in the rear panel of the E436xA modules; it is used to connect external current monitors and programming sources. Analog connectors are also used to connect modules together in the auto-parallel mode.

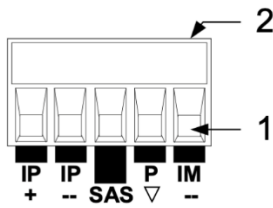

Analog connectors in E436xA modules

MP4300

Analog connectors are not available for the MP436x modules.

Parallel connection

There are two ways to connect outputs in parallel in the E4360A mainframe. Note that the parallel connection type must be specified while programming the modules. Ensure connections are made at the load, not at the output connectors.

CAUTION: Do not connect power modules with a different voltage or current ratings together

1. Direct-parallel method: In this method, the module outputs are directly connected in parallel to a load and individually programmed. This is the simplest and quickest way of making parallel connections in the SAS. This method is recommended for SAS and table modes—due to the high impedance of the output channel when operating in these modes. This method may also be connected under fixed mode in the same manner. However, due to the low output impedance of each channel in fixed mode, the current division among modules may be uneven.

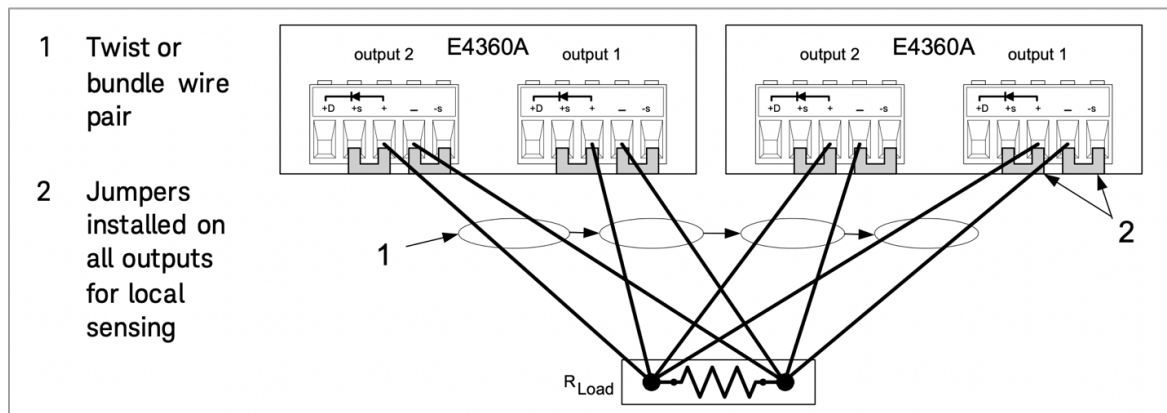

Figure 9.E430A Direct-Parallel connections

2. Auto-parallel method: This method includes one of the modules acting as a “master” channel and the remaining modules serving as “follower” channels connected via analog channels. This configuration ensures that the current is equally divided across the modules. This method is recommended while operating in fixed mode. Auto-paralleling could be implemented in SAS and table modes but will cause worse programming accuracy across modules.

NOTE: For auto-paralleling in SAS and table mode, the connections remain the same as Figure 10, but the additional circuits, 5a and 5b, are omitted

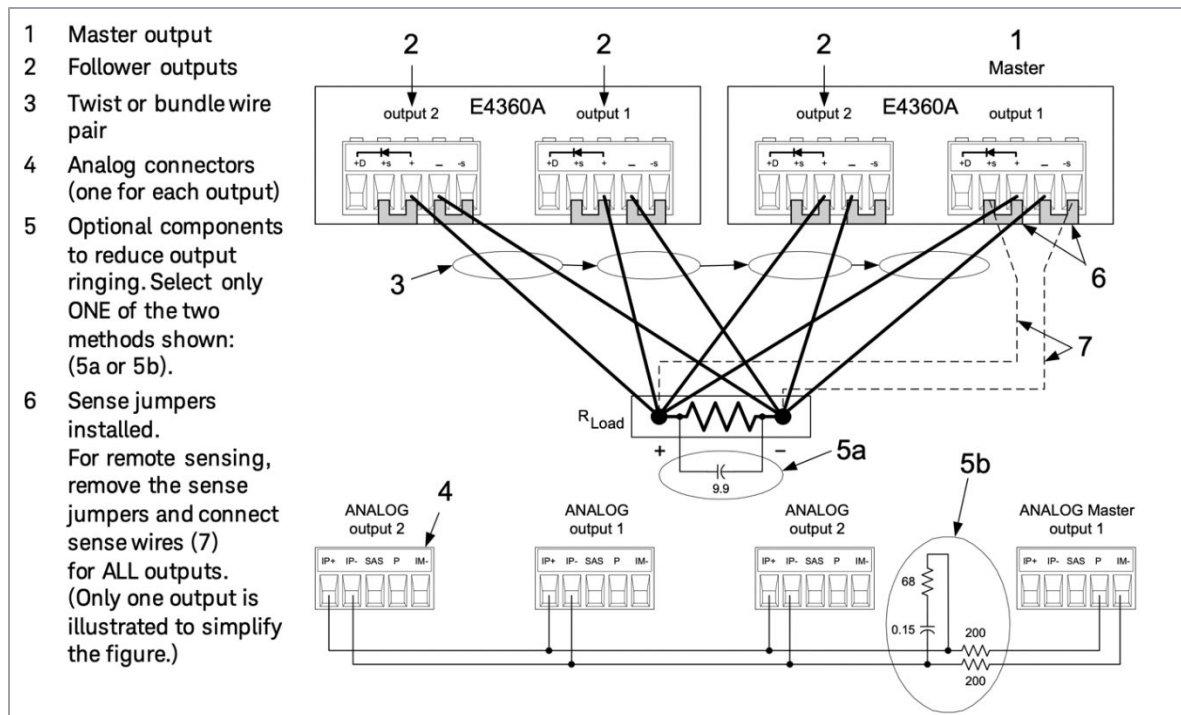

Figure 10. E430A Auto-Parallel connections.

The MP4300A does not contain analog connectors—and as a result, users cannot manually set the mainframe to auto-parallelism. However, the function is now internally controlled in the backplane of the MP4300 with digital auto parallel.

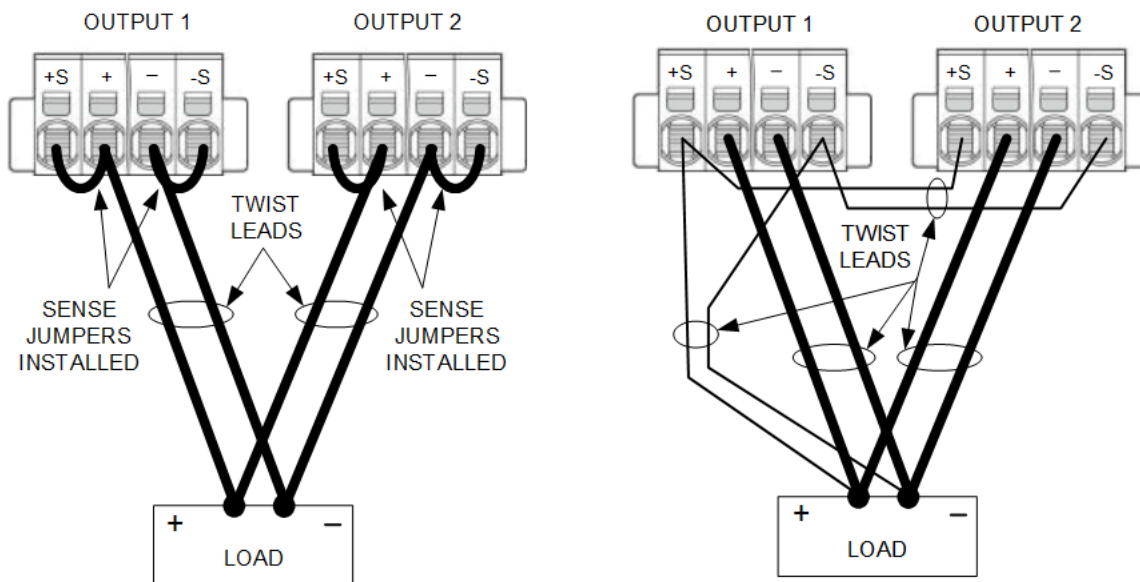
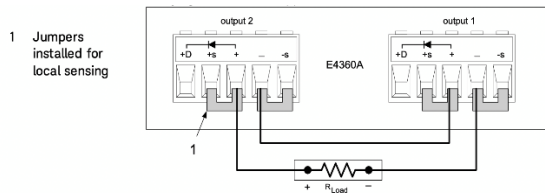

Figure 12. MP4300 local and remote sense parallel connections

Series connections

E4360A

SAS modules can generally be connected in series to increase voltage capability. It is important that the combined modules have equivalent ratings—as variations in current ratings could damage lower-rated outputs.



MP4361A/ MP4362A

The MP4300 does not support series connections, as the maximum floating voltage is limited to 240V. With the MP4361A having a maximum output voltage of 160V and the MP4362A at 130V, connecting them in series would surpass the allowable floating voltage threshold.

Please contact Keysight support if you need to use a series connection.

Grouping the outputs

Grouping allows users to control two modules to make them act as a single, higher-rated output. All modules are connected in parallel, and each channel current sums up to produce one maximum output current. Grouping can be set through the front panel and SCPI commands in both mainframes. See the user guides for additional help with grouping channels together in the E4360A and MP4300.

E4360A

- Up to 2 output channels can be grouped for a mainframe.
- Grouping is either used in direct-parallel or auto-parallel mode—where the selected mode is connected similarly between modules. For auto-parallel, a master and follower channel is specified.

MP4300

- Up to 6 output channels can be grouped for a mainframe.
- Grouping is used in digital auto parallel mode.

NOTE: Grouping is only permitted across parallel connections.

Additional Features of the MP4300 SAS

Regenerative operation

Standard power supplies generally only prohibit energy flow from the AC input to their DC output terminals; A regenerative system also permits energy flow from the output terminals back to the AC mains. The MP4300 can direct excess power at the output back to the mainframe—a useful feature while sinking current in different applications. Note that the regenerative operation cannot be disabled in the unit.

2-Quadrant operation

The Keysight MP4361A is capable of sourcing and sinking power, i.e., a 2-quadrant source. This allows users to communicate from source to lead in a single mainframe. 2-quadrant sourcing/sinking allows one to transition from sourcing to sinking without disrupting the power supply.

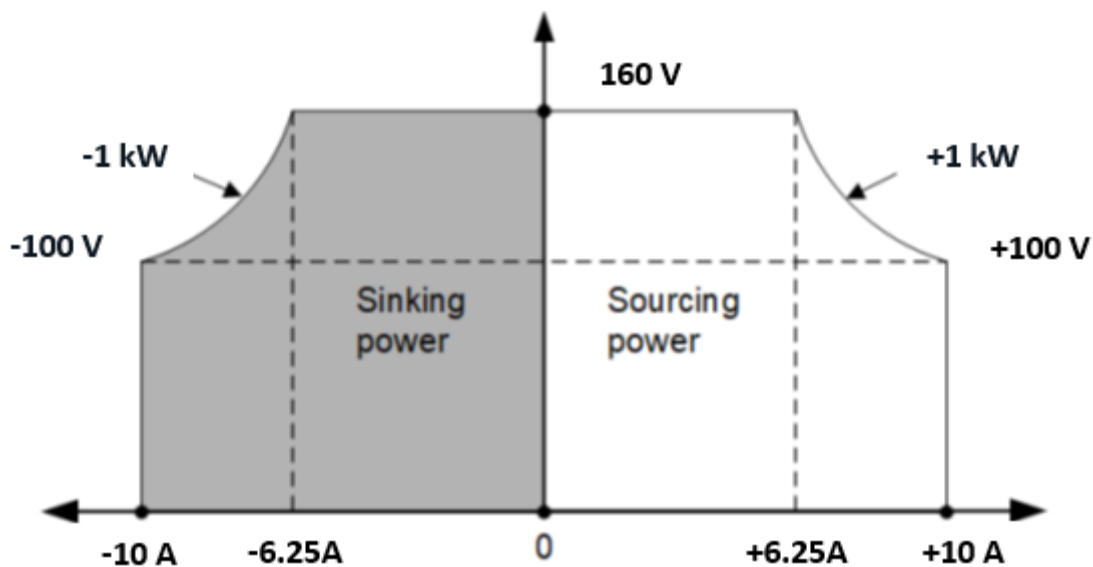

Figure 13. Output quadrants of the MP4361A

Autoranging operation

MP4361A Solar Array simulator is an auto-ranging module. It has 8 auto-ranging output characteristics for greater flexibility.

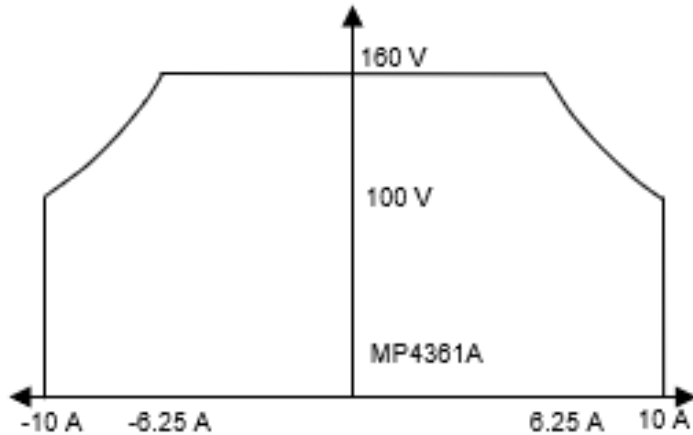

Figure 14. Output characteristics for MP4361A solar array simulator system modules

Compensation mode available for SAS operations

The digital control capability of the SAS module allows for flexible, firmware-based compensation modes which can be tailored for different applications to achieve optimal performance.

Available compensation mode: DEFAULT, DCDC_20UF, and SHUNTSW.

Depending on the application, you need to specify the compensation modes for optimal measurement performance.

Application	DEFAULT	DCDC_20UF	SHUNTSW
Initial turn-on/debug of MPPT and shunt switching DUTs with no external capacitance required	Recommended	Not recommended	Not recommended
Performance testing of MPPT DUTs with a minimum of 20 μ F external capacitance	Recommended	Recommended	Not recommended
Performance testing DC to DC regulation DUTs with a minimum of 20 μ F external capacitance	Not recommended	Recommended	Not recommended
Performance testing of shunt switching DUTs	Not recommended	Not recommended	Recommended

DEFAULT Mode

The DEFAULT mode is intended for initial turn-on and debugging when operating in solar array simulation mode. It is a low-performance mode for initial confirmation of system hardware interconnections to the DUT and verification of basic SAS mode operation with a static load. It is not optimized for use with specific DUT types, such as DC/DC converters, MPPT trackers, or shunt-switching control schemes.

- Not recommended for performance evaluation of DC/DC converter, MPPT, or shunt switching DUTs
- Will not provide stable operation with an active DC/DC converter in regulation mode.
- Recommended for initial verification of hardware configuration with a static load.

DCDC_20UF Mode

DCDC_20UF mode with capacitance applies for DC/DC converter applications where bus regulation is implemented. This requires a minimum of 20uF external capacitance. This is the only compensation mode that can handle bus regulation for DC/DC converters. The following are the key operating characteristics of DCDC_20UF mode with capacitance:

- Recommended for DC/DC converter and MPPT applications.
- Optimized for operation above V_{mp} when the DUT has a constant power input impedance characteristic, such as converters providing bus regulation.
- Also recommended for DUTs with constant voltage, current, or resistance input impedance characteristics, such as converters providing MPPT tracking at any voltage on the SAS curve. An operation is allowed at any voltage on the SAS curve for these characteristics.
- Requires a minimum of 20 μF external capacitance at the sense point.
- Require remote sensing. In addition, capacitance that is separated from the sense point by a series diode does not contribute to the 20 μF minimum.

SHUNTSW Mode

The following are the key operating characteristics of the SHUNTSW mode:

- Optimized for shunt switching operation where the output terminal voltage alternates between two steady levels, one of which is around zero volts.
- No minimum external capacitance requirement.
- Recommended for shunt-switching applications only.
- If the DUT is a constant power load, V_{mp}/I_{mp} must be greater than or equal to 5 ohms.
- Supports local or remote sensing.

Solar array simulators are generally installed as part of a large-scale, rack-based system. The system is then launched into test areas- into space for most scenarios- and observations are made remotely. Therefore, it is important that the instruments used are capable of running at a highly efficient degree, as in-test modifications are nearly impossible to make.



Due to the much larger sinking capability of the MP4361A compared to any other SAS module, a new leeway is set for rack system configuration. The MP4300 can serve as both a source and load, and different series and parallel combinations can be produced all in a single unit, depending on the limits. On a large scale, this configuration creates much more rack space and serves as a more efficient simulation.

Additional Information

Description	Document	Content
User guides and manuals	<ul style="list-style-type: none">E4360A User GuideMP4300 User Guide	Basic installation & operation guides, Power Module Commands
Programming Guides	<ul style="list-style-type: none">E4360A Programming GuideMP4300 Programming Guide	Introduction to programming the mainframes and modules, language dictionaries, status reporting, and synchronizing power modules
Datasheet	<ul style="list-style-type: none">E4360A Data sheetMP4300 Data Sheet	key and supplemental specifications for mainframe and module, additional features of mainframes, Extended classification of modules
I/O Library Suite	Keysight IO libraries suite download	Software for instrument connection and cross-interaction with various programming environments

Appendix A

Product specifications

E4360A — MP4300 Mainframes comparison table

Model	E4360A	MP4301A	MP4302A
Command Processing Time	<= 1ms from receipt of the command to start of output charge		
Interface Capabilities			
GPIB	SCPI – 1993, IEEE 4888.2 compliant interface		
LXI Compliance	Class C		
USB	2.0		
LAN	10 MB, 100 MB LAN	10 MB, 100 MB, 1GB LAN	
Built-in web server	Yes		
Digital Control Characteristics			
Maximum voltage ratings	+16.5 VDC/ -5 VDC between pins		
FLT outputs pins	Pins 1 & 2 Maximum low-level output voltage = 0.5V @ 4mA Maximum low-level sink current = 4mA Typical High-level leakage current = 1mA@ 16.5 VDC		
Digital/trigger outputs pins	Pins 1-7 Maximum low-level output voltage = 0.5V @ 4mA 1 V @ 50 mA; 1.75V @100 mA Maximum low-level sink current = 100mA Typical High-level leakage current = 0.8 mA @ 16.5 VDC		
Input pins	Pins 1-7 Maximum low-level input voltage = 0.8V Minimum high-level input voltage = 2V Typical low-level sink current = 2mA @ 0V (Internal 2.2k pull-up) Typical High-level leakage current = 0.12mA @ 16.5 VDC		
Common Pins	Pin 8 Internally connected to chassis ground		
Number of channels			
	2	6	
Maximum output power			
	1.2kW	6kW	
AC Mains			
Nominal Input ratings	100-240 VAC 50/60/400 Hz	200-208 VAC 50/60 Hz	380-480 VAC 50/60 Hz
Phase	Single	Three Phase	
Power consumption	2000 VA	7200 VA	
Dimension & Weight			
Height	88.1 mm (3.5 in)		
Width	432.5 mm (17.03 in)	428.9 mm (16.89)	
Depth	633.9 mm (24.96 in)	750.9 mm (29.56 in)	
Weight	17.6 kg / 38.4 lbs.	29.5 kg / 65 lbs.	

E4361A / E4362A — MP4361A / MP4362A modules comparison table

Model	E4361A	E4362A	MP4361A	MP4362A
DC Output ratings	65 V/8.5 A/510 W	130 V/5 A/600 W	160 V/10 A/1000 W	130 V/8 A/1000 W
Programming Accuracy	0.075% + 25 mV 0.2% + 20 mA	0.075% + 50 mV 0.2% + 10 mA	0.05% + 15 mV 0.05% + 5 mA	0.08% + 20 mV 0.2% + 25 mA
Ripple & Noise (Between 20 Hz – 200 Hz)				
V_{P-P}	150 mV	150 mV	350 mV	350 mV
V_{rms}	24 mV	30 mV	40 mV	40 mV
Transient response	< 1 ms	< 1 ms	< 0.1 ms	< 0.1 ms
Load regulation				
Voltage	2 mV	2 mV	2 mV	2 mV
Current	1 mA	1 mA	1 mA	1 mA
Line regulation				
Voltage	2 mV	2 mV	2 mV	2 mV
Current	1 mA	1 mA	1 mA	1 mA
No of slots occupied	2	2	1	1
Autoranging Capability	No	No	Yes	No
2- quadrant source/sink operation	No	No	Yes	No
Current sinking capability				
SAS/Table mode	560 mA	560 mA	500 mA	500 mA
Fixed mode	440 mA	440 mA	10 A	500 mA
Series and shunt switching frequency	50 kHz maximum	50 kHz maximum	20 kHz maximum	20 kHz maximum
Weight	3.3 kg / 7.2 lbs	3.3 kg / 7.2 lbs	1.7 kg / 3.8 lbs	1.7 kg / 3.8 lbs

Appendix B

Outline diagrams

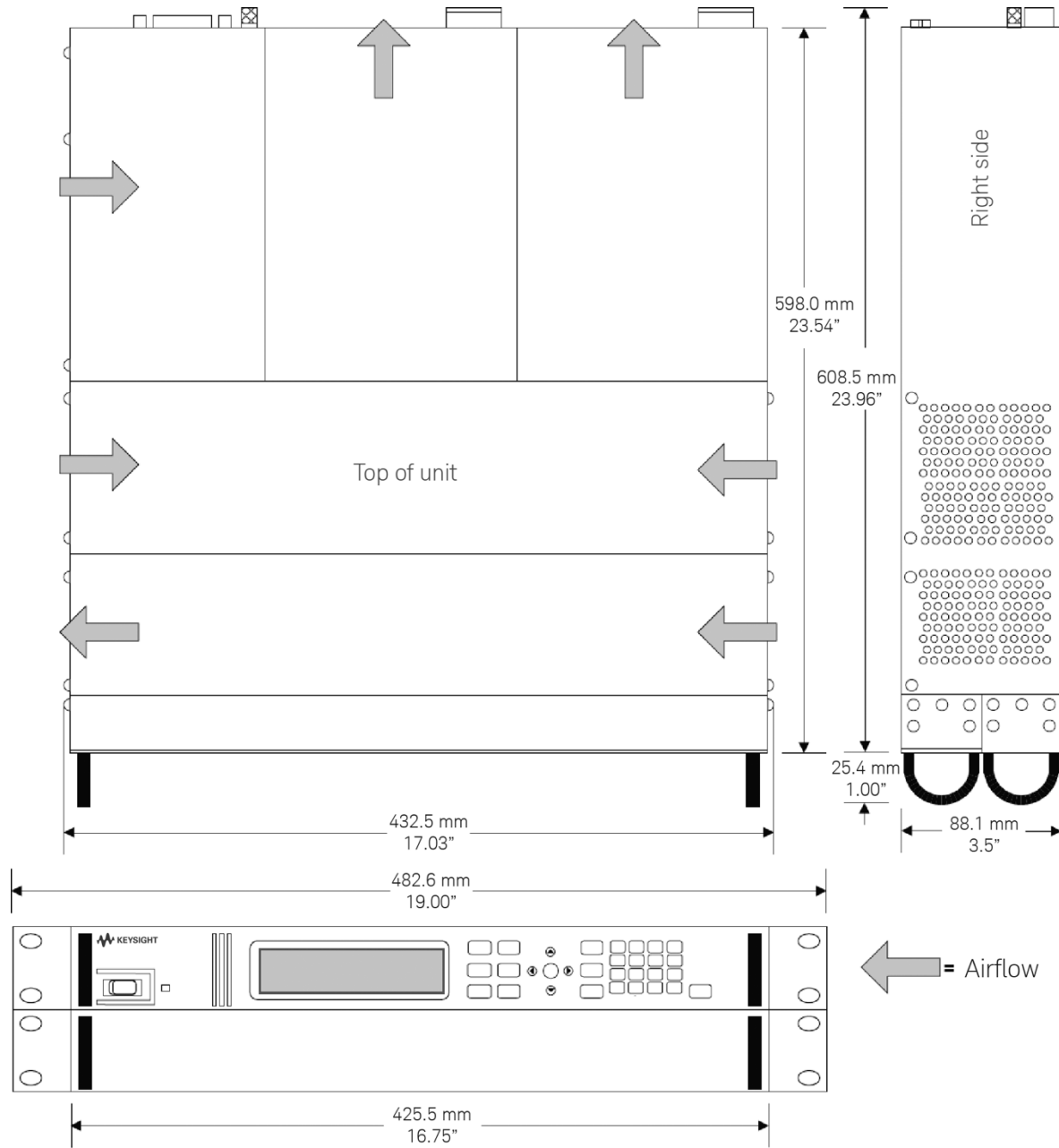

Figure 15. Diagram and airflow for the E4360A mainframe

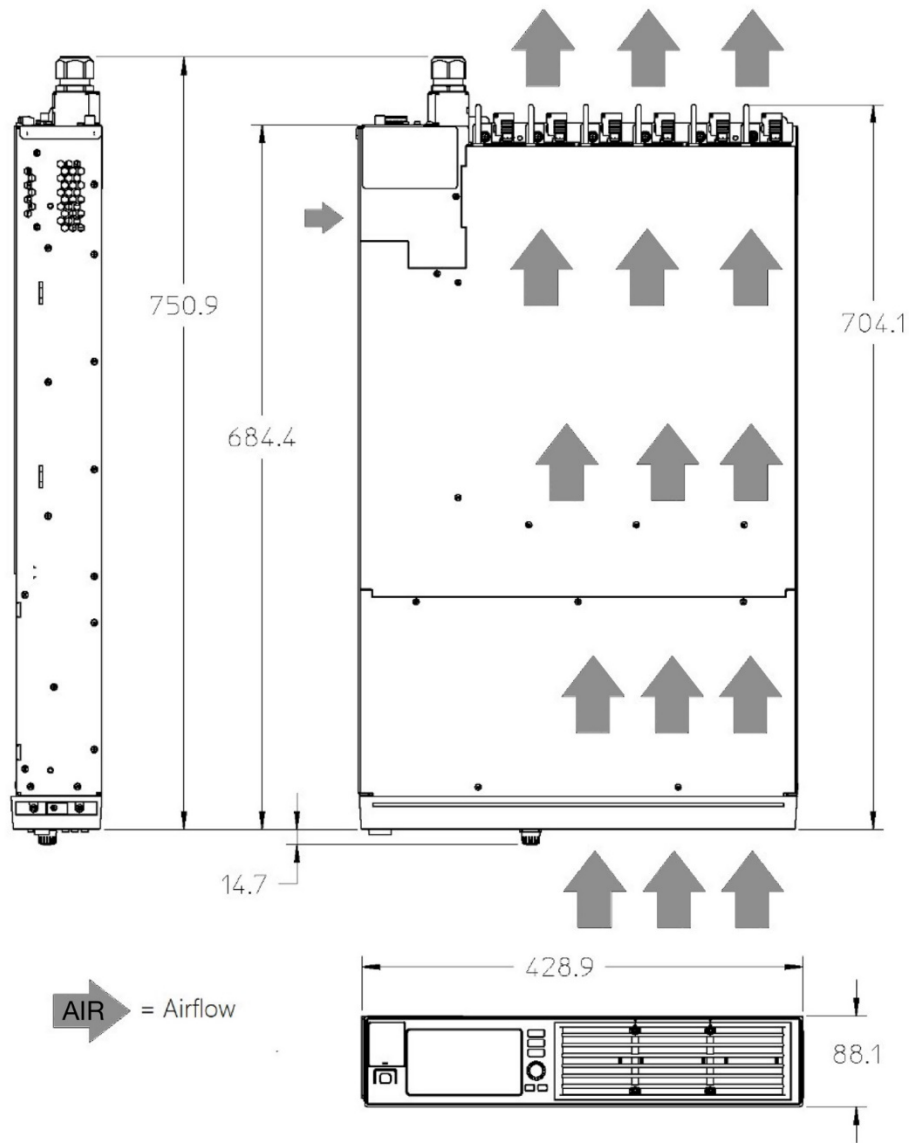

Figure 16. Diagram and airflow for the MP4300 mainframe



Mess- und Prüftechnik. Die Experten.

Ihr Ansprechpartner /
Your Partner:

dataTec AG

E-Mail: info@datatec.eu

>>> www.datatec.eu

Keysight enables innovators to push the boundaries of engineering by quickly solving design, emulation, and test challenges to create the best product experiences. Start your innovation journey at www.keysight.com.

This information is subject to change without notice. © Keysight Technologies, 2023,

