



TECHNICAL
OVERVIEW

Power Divider

11636A/B/C/D: DC to 18/26.5/50/67 GHz

Key Features

- Broad operating frequency range up to 67 GHz eliminates the need for multiple dividers
- Excellent amplitude and phase tracking ensures highly accurate power division
- Low SWR minimizes measurement uncertainty

Description

The Keysight Technologies, Inc. 11636x power divider provides good matching and excellent tracking characteristics for highly accurate power division, signal routing and matrix testing from DC up to 67 GHz. Offering excellent output power symmetry between the two outputs ports, the 11636x is recommended for applications such as power combining and transmission line fault testing using a network analyzer. The excellent source match of all three ports improves fault location measurements by reducing reflections. These power dividers are not recommended for ratio or source leveling applications.

The Keysight 11636x provides a symmetrical 6 dB power division. It can also be used as power combiner: when signal is input at the two output ports, the sum of the two signals appears at the input port.

Applications

Power dividing

The Keysight 11636x power divider uses three $16 \frac{2}{3} \Omega$ resistors for direct power dividing applications such as splitting one source into two parts for separate measurements or distributing low power signals into two or more antennas.

The power divider can also be used for broadband independent signal sampling in test systems. Using a power divider, the test system simultaneously measures two different characteristics of a signal, such as frequency and power. Figure 1 shows a power divider used in a simple power dividing application.

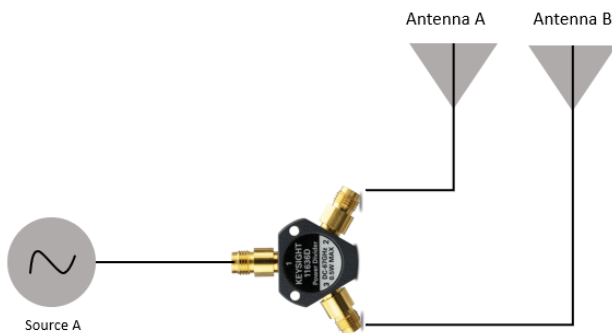

Figure 1. Test setup for power dividing application

Power combining

Power dividers also can act as a power combiner. Figure 2 shows the Keysight 11636x power divider combining the two signals from the different sources into the DUT. The power divider provides a good impedance match at both the output arms when the input is terminated in the system's characteristic impedance (50Ω).

Once a good source match has been achieved, the three-resistor power divider may be used to divide the output into equal signals for comparison measurements.

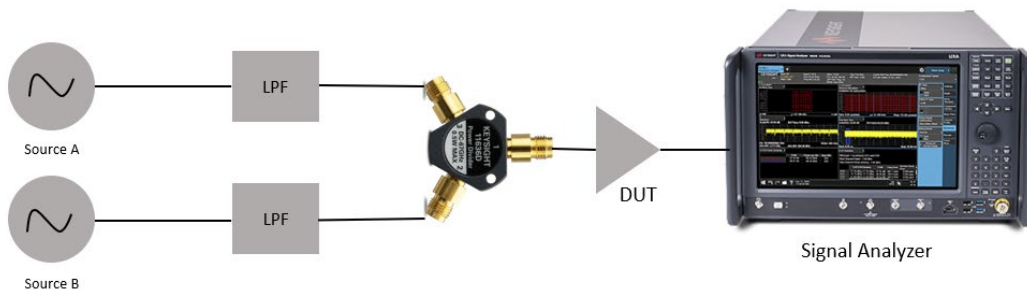

Figure 2. Test setup for power combining application

Specifications

Specifications describe the instrument's warranted performance. Supplemental and typical characteristics are intended to provide information useful in applying the instrument by giving typical, but not warranted performance parameters. 11636x specifications are tested at nominal voltage at 25 °C.

Specifications	11636A	11636B	11636C	11636D
Frequency range	DC to 18 GHz	DC to 26.5 GHz	DC to 50 GHz	DC to 67 GHz
Max input power (W)	1	0.5	0.5	1
Phase tracking (°) typical	2	3	2	DC to 50 GHz: 4 50 to 67 GHz: 7
Amplitude tracking (dB)	DC to 4 GHz: 0.2 4 to 10 GHz: 0.4 10 to 18 GHz: 0.5	DC to 18 GHz: 0.25 18 to 26.5 GHz: 0.50	0.3	DC to 50 GHz: 0.4 50 to 67 GHz: 0.65
Insertion loss (dB)	6 (-0.2, +1.2 max to 10 GHz; +1.5 max to 18 GHz) nominal	DC to 26.5 GHz: 7.5 max	DC to 18 GHz: 6.5 18 to 26.5 GHz: 7.0 26.5 to 40 GHz: 8.0 40 to 50 GHz: 8.5	DC to 18 GHz: 7.0 18 to 26.5 GHz: 7.5 26.5 to 40 GHz: 8.5 40 to 50 GHz: 9.0 50 to 67 GHz: 9.0
Return loss, dB (VSWR)	DC to 10 GHz: 19 (1.25) 10 to 26.5 GHz: 17 (1.35)	DC to 10 GHz: 20 (1.22) 10 to 26.5 GHz: 18 (1.29)	DC to 18 GHz: 20 (1.22) 18 to 26.5 GHz: 16 (1.38) 26.5 to 40 GHz: 14 (1.50) 40 to 50 GHz: 12 (1.67)	DC to 18 GHz: 19 (3.0) 18 to 26.5 GHz: 15 (4.0) 26.5 to 40 GHz: 13 (6.0) 40 to 50 GHz: 11 (8.0) 50 to 67 GHz: 9 (2.1)
Connector	One Type-N (m), two Type-N (f)	3.5 mm (f) all ports	2.4 mm (f) all ports	1.85 mm (f) all ports

Typical Performance

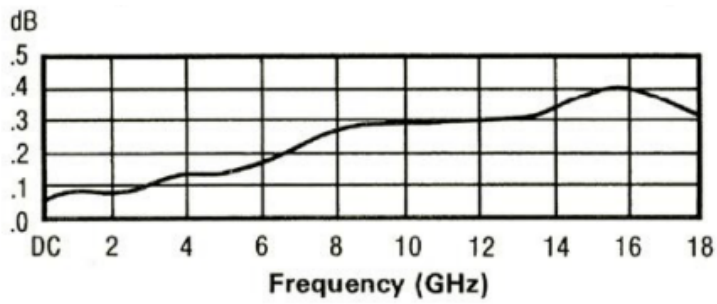

Figure 3. 11636A tracking between output arms (typical)

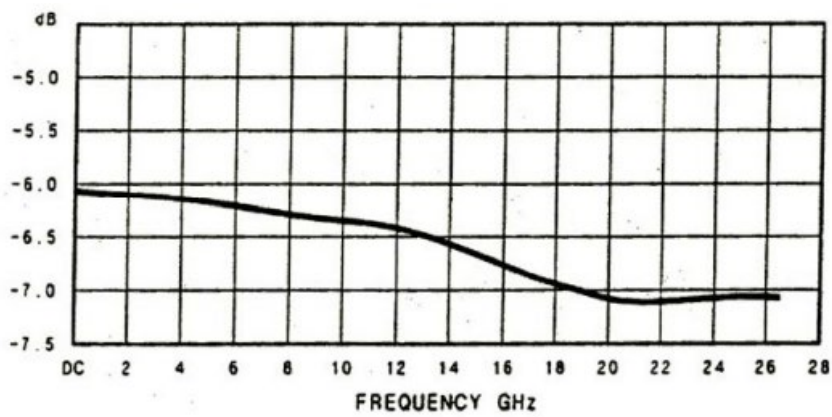

Figure 4. 11636B insertion loss versus frequency (typical)

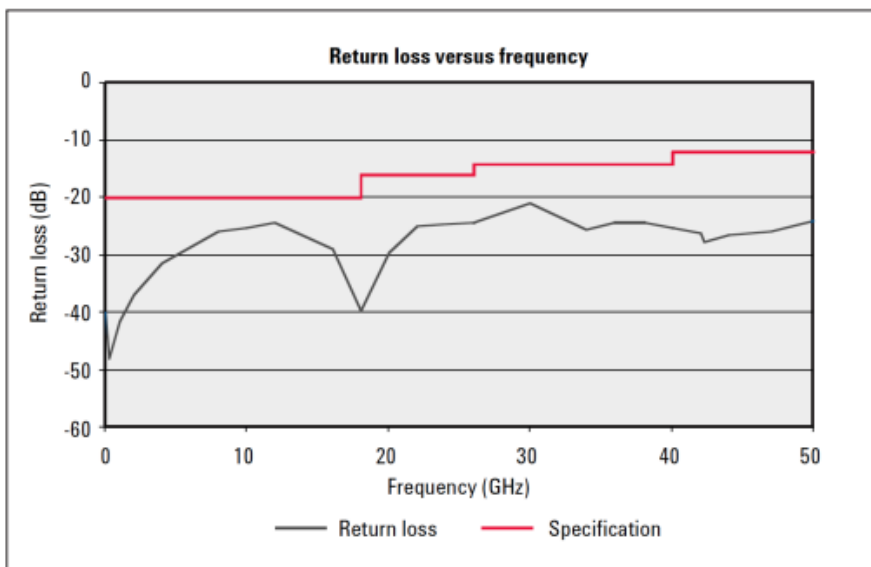

Figure 5. 11636C return loss versus frequency (typical)

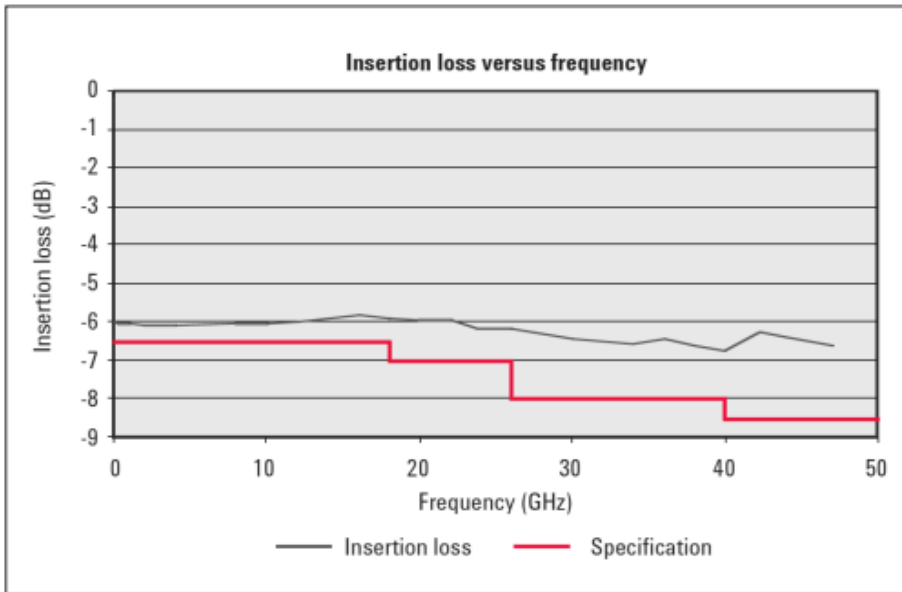

Figure 6. 11636C insertion loss versus frequency (typical)

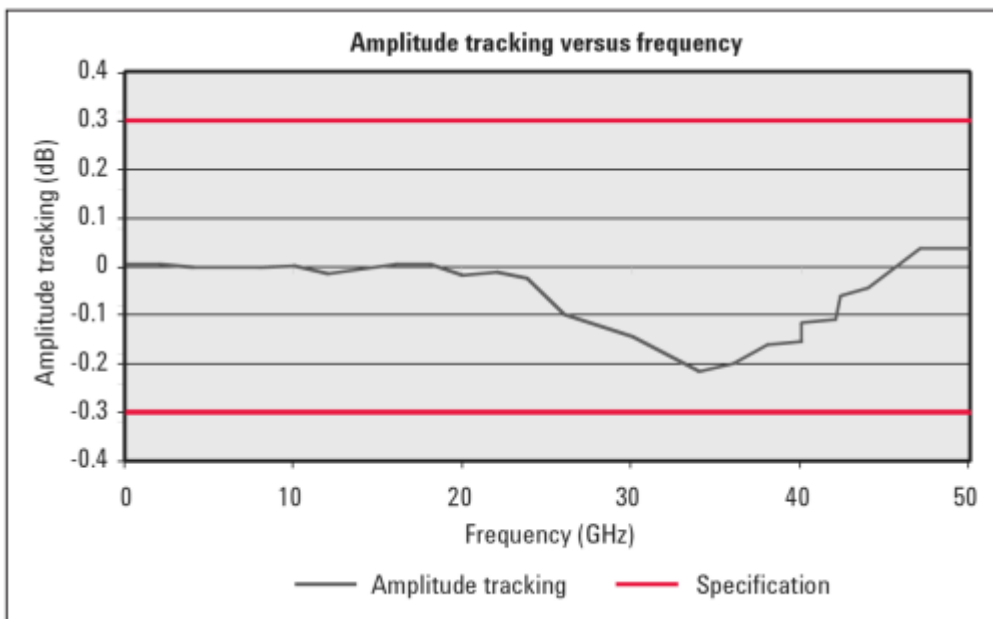

Figure 7. 11636C amplitude tracking versus frequency (typical)

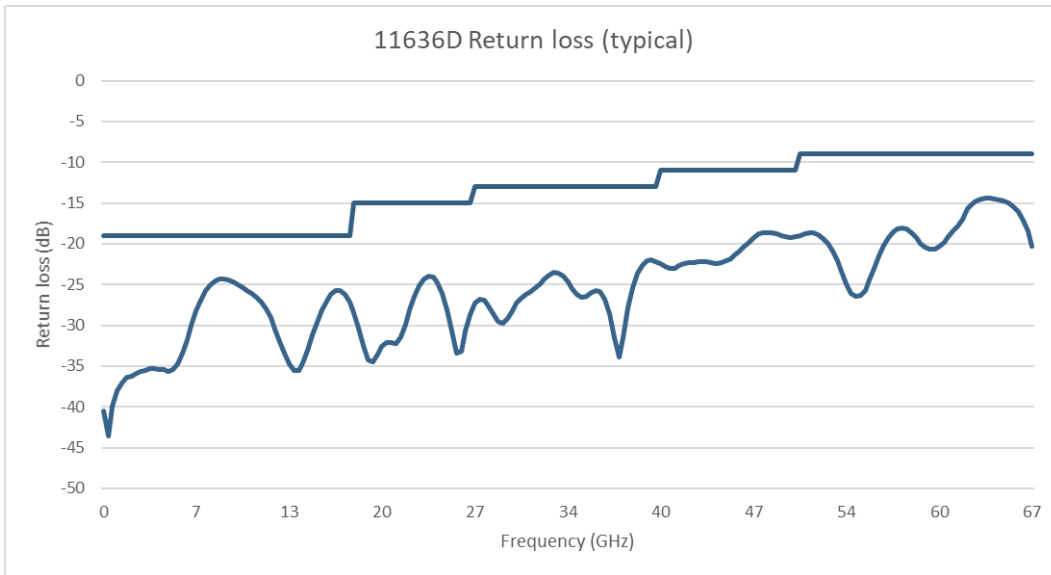

Figure 8. 11636D return loss versus frequency (typical)

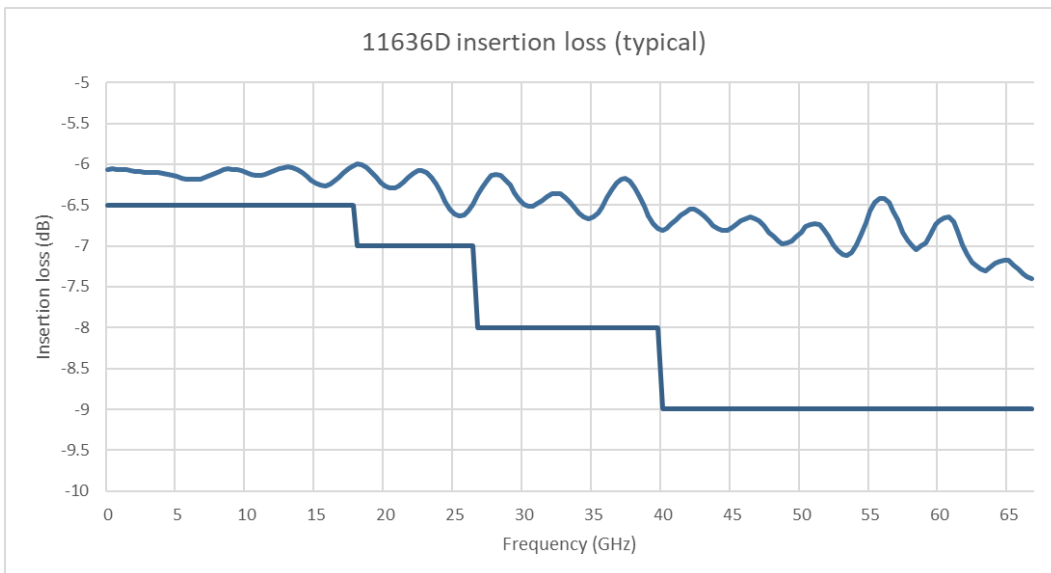

Figure 9. 11636D insertion loss versus frequency (typical)

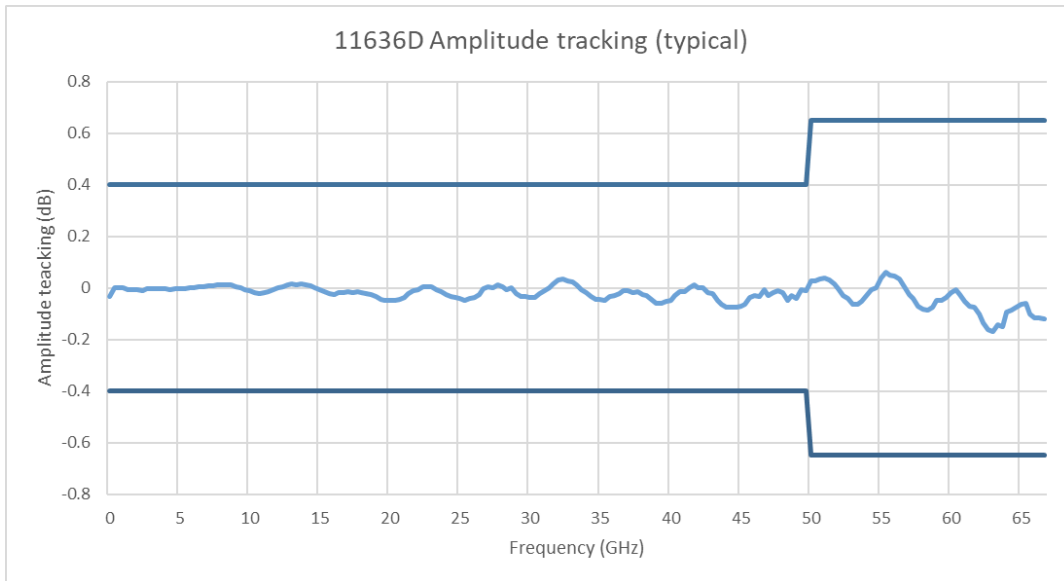

Figure 10. 11636D amplitude tracking versus frequency (typical)

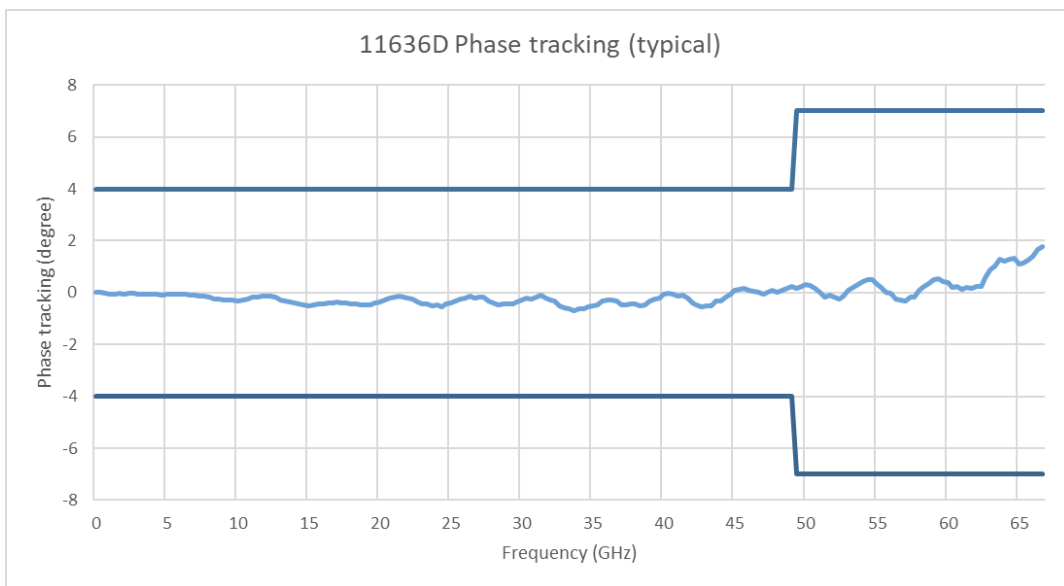

Figure 11. 11636D phase tracking versus frequency (typical)

Environmental Specifications

The 11636x power divider are designed to fully comply with Keysight Technologies' product operating environment specifications. The following summarizes the environmental specifications for these products.

Environment condition	11636C
Temperature Operating Storage Cycling	-45 °C to +70°C -65 °C to +85°C -65 °C to +85°C, 10 cycles at 20 °C per minute ramp rate, 20 minutes dwell time per MIL-STD-883F, Method 1010.8, Condition C (modified)
Humidity Operating Storage	50% to 95% RH at 40 °C, 24 hours cycling, 5 cycles 90% RH at 65 °C, 24 hours
Shock End-user handling Mechanical survival Transportation	Delta-V: 3m/s ±5%, Duration <3ms at 6 faces Half Sine: 1000g, 0.5ms at 6 faces 50g, delta-V: 8m/s at 6 faces
Vibration Operating random	2.41 Grms, 10 min/axis
Altitude Operating Non-operating	4,600 meters (15,092 feet) 4,600 meters (15,092 feet)
ESD immunity Direct discharge Air discharge	4 kV (to center conductor) 15 kV (to outer conductor)

Environment condition	11636D
Temperature Operating Storage Cycling	-45°C to +70°C -65 °C to +85°C -65 °C to +85°C, 10 cycles at 20 °C per minute ramp rate, 20 minutes dwell time per MIL-STD-883F, Method 1010.8, Condition C (modified)
Humidity Operating Condensation Resistance	95% RH at 40°C, 24 hours cycling, 5 cycles 95% RH at -10°C to 25°C, Method 2 95% RH at 65°C, 10 Days per JEDEC HAST Standard
Shock End-user handling Mechanical survival Transportation	Delta-V: 3m/s ±5%, Duration <3ms at 6 faces Half Sine: 1000g, 0.5ms at 6 faces 50g, delta-V: 8m/s at 6 faces
Vibration Operating random	0.3 Grms, 5-500 Hz
Altitude Operating Non-operating	4,600 meters (15,092 feet) 4,600 meters (15,092 feet)
ESD immunity Direct discharge Air discharge	4 kV (to center conductor) 15 kV (to outer conductor)

Mechanical Dimensions

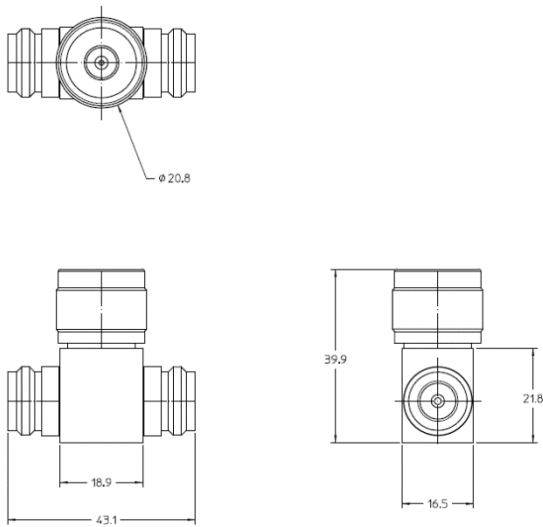

Figure 12. 11636A mechanical dimensions

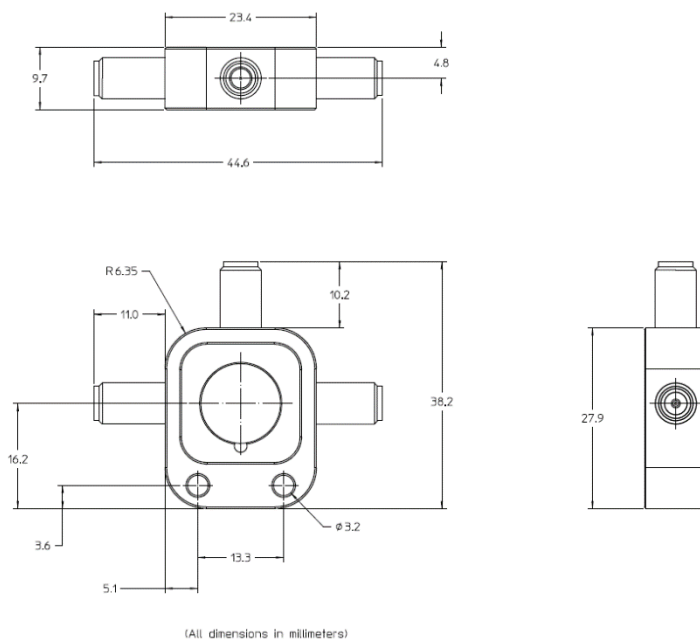

Figure 13. 11636B mechanical dimensions

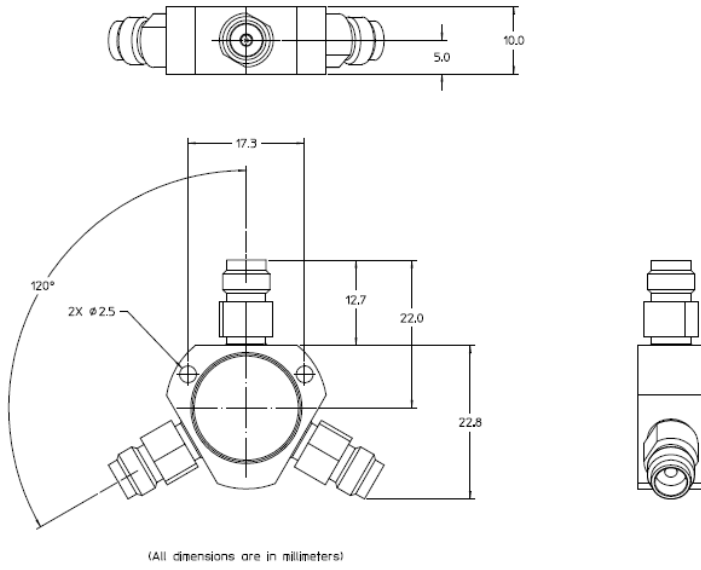

Figure 14. 11636C/D mechanical dimensions

Ordering Information

Model	Description
11636A	Power Divider, DC to 18 GHz
11636B	Power Divider, DC to 26.5 GHz
11636C	Power Divider, DC to 50 GHz
11636D	Power Divider, DC to 67 GHz

Wir haben die Lösungen für Ihre Mess- aufgaben.

dataTec

Mess- und Prüftechnik, Die Experten.

Ihre Vorteile:

- > Diplom-Ingenieure, Elektronik- und Elektrotechniker
- > Langjährige Praxiserfahrung und hohe Kompetenz
- > Bundesweit über 20 praxiserfahrene und herstellerzertifizierte Vertriebsingenieure im Außendienst bei Ihnen vor Ort

Experten für:

- > Oszilloskope
- > Spektrum- / Netzwerkanalysatoren
- > Netzgeräte / Stromversorgungen
- > Thermografie / Temperatur
- > Prüfgeräte VDE / Netzanalyse
- > u. v. m.

