

## IsoVu Isolated Current Probes TICP100, TICP050, TICP025 Datasheet

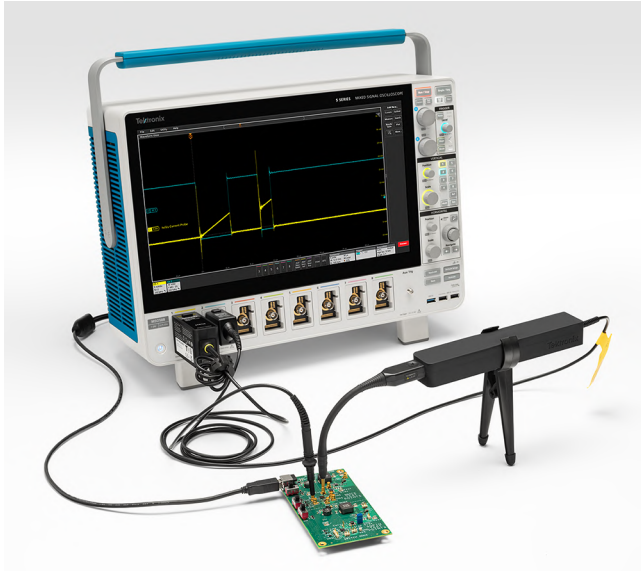

### Overview

The IsoVu™ isolated current probes deliver exceptional bandwidth, noise rejection, accuracy, and ease of use for making current measurements.

Complete galvanic isolation eliminates ground loops and enables very high common mode rejection. In a 1X configuration, the probe's 50 Ω input offers extremely low noise of less than 4.7 nV/√Hz, ideal for making accurate measurements on shunts. The probes offer a variety of attenuation tips to extend the differential voltage range. Depending upon the shunt used, the probes can perform current measurements from microamperes (μA) for low-power mobile designs to hundreds of amperes for industrial and mobility systems.

### Key performance specifications and features

- Galvanic isolation between probe tip and the oscilloscope
- Available in three bandwidths: 1 GHz, 500 MHz, and 250 MHz
- Wide current measurement range determined by the shunt used with 1X, 10X or 100X probe tips
- Noise <math>< 4.70 \text{ nV} / \sqrt{\text{Hz}}</math> (<math>< 21 \text{ } \mu\text{V}\_{\text{RMS}}</math> at 20 MHz)
- Up to 90 dB CMRR at 1 MHz
- Maximum common mode voltage: 1800 V; For use in a Pollution Degree 1 environment; transient level not to exceed 5 kV<sub>pk</sub>
- 1.5% DC gain accuracy

- Compatible with the 4, 5, and 6 Series MSO instruments, including the latest B models
- TekVPI™ interface enables control and probe configuration from the oscilloscope front panel or programming interface
- Optional tips to measure currents in environmental chambers from -40°C to +125°C

### Key applications

- Current shunt measurements
- Half/full bridge designs using SiC or GaN, FETs, or IGBTs
- Double pulse testing (DPT)
- Floating gate measurements
- Power converter designs
- Switching power supply designs
- Steady state, sleep, and wake-up state current monitoring

### Tips expand measurement ranges, minimize hassle, and reduce noise

The IsoVu isolated current probes are well-suited for both low current and high current measurements that are challenging or impossible with sensor-based clamp-on oscilloscope probes. With three different attenuation tips, you can easily measure a wide range of currents based on the shunt resistance and its power rating.

The probes are designed to provide high-performance current measurements while offering convenient connectivity. Tips are equipped with MMCX and SMA connectors to ensure proper grounding and shielding, which is crucial for minimizing noise, ground loops, and ensuring accurate current measurements. These tips enable direct connection to most commercially available shunts, but you can also use appropriate adapters to interface the tips with their shunts.

The probe tips connect to the probe body with a unique reversible IsoConnect™ interface, allowing you to snap-fit the tips without worrying about orientation. Designed for flexibility, the probe tips have a small bend radius, facilitating connection in tight spaces. The standard probe includes a tripod adapter and a bipod for convenient placement and positioning in the test setup.



Mess- und Prüftechnik. Die Experten.

**Ihr Ansprechpartner /  
Your Partner:**

**dataTec AG**  
E-Mail: [info@datatec.eu](mailto:info@datatec.eu)  
[datatec.eu](http://datatec.eu)

## Current shunt measurements

There are two methods to measure current in test systems. The first method involves sensing the fields around the electrical conductors and converting them into signals that represent the current. This method is used by most clamp-on style current probes, or Rogowski coils. The second method involves measuring currents using Ohm's law. One can measure current by measuring the voltage drop across a precision shunt resistor, which is the method used by the IsoVu isolated current probes.

Current shunts, or current viewing resistors (CVRs), typically have a wide frequency response, accurately measuring both AC and DC currents across a broad spectrum of frequencies. Their compact size allows for easy integration into existing circuitry with minimal space requirements. Although shunt resistors must be designed into a PCB and result in voltage drop, they offer some key advantages compared to sensor-based current measurements, including high accuracy, minimal distortion, and low interference.

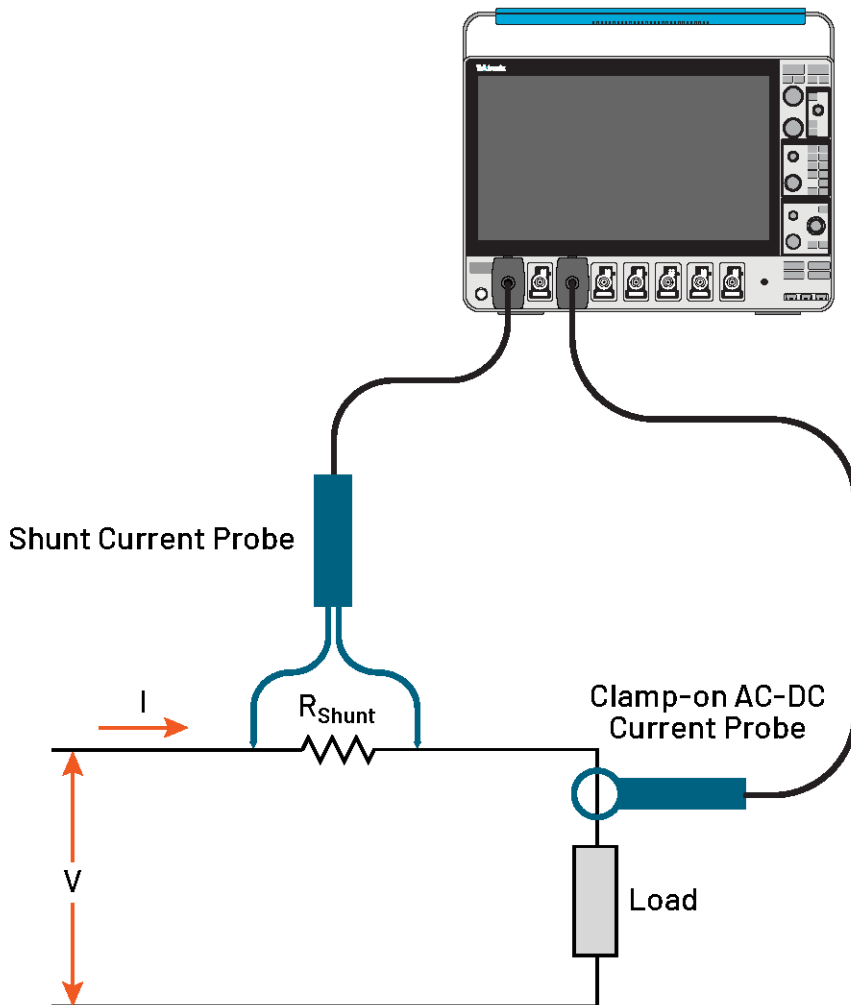

## Isolation enables floating measurements and exceptionally low noise

The IsoVu isolated current probes enable you to make more accurate dynamic current measurements on your oscilloscope, outside traditional limits.

Unlike transformer, Rogowski, or Hall effect current probes, IsoVu isolated current probes enable measurements from DC to hundreds of MHz when paired with high-performance shunts or CVRs. Complete RF isolation between the probe tip and the oscilloscope eliminates ground loops and helps deliver extraordinary common mode rejection (CMRR) up to 90 dB at 1 MHz to dramatically reduce common mode noise. Low attenuation and low input impedance ( $50\ \Omega$ ) limits noise contribution to less than  $4.7\ \text{nV}/\sqrt{\text{Hz}}$  noise contribution ( $<150\ \mu\text{V}$  at 1 GHz) when measuring low voltages ( $\pm 0.5\ \text{V}$ ) across shunts.

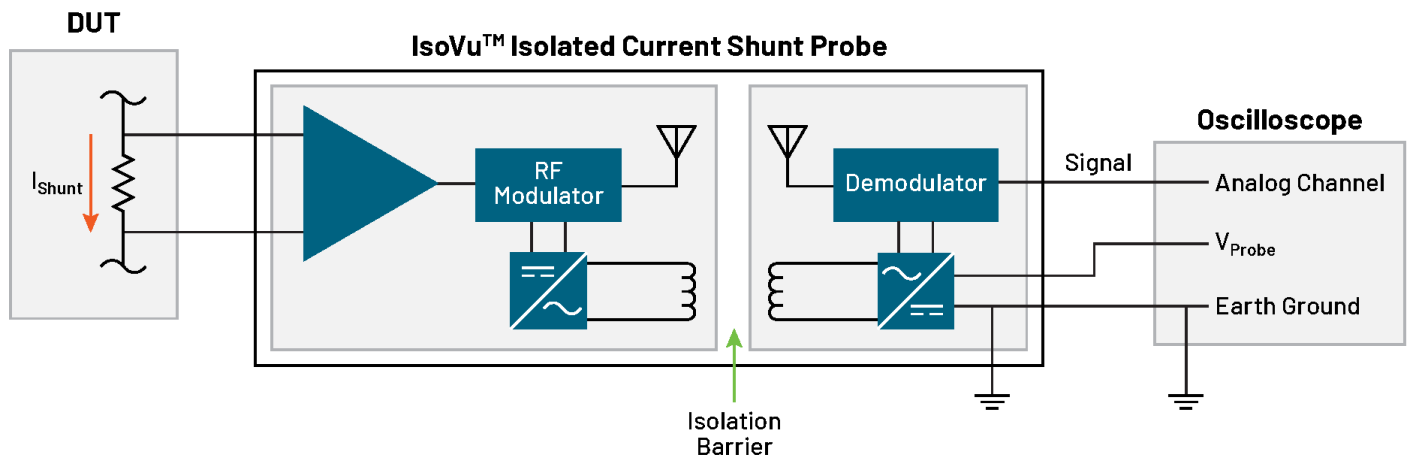

## Test beyond ambient temperature with extreme temperature tips

The extreme temperature (ET) tips enable current measurements across a wide temperature range from  $-40^{\circ}\text{C}$  to  $+125^{\circ}\text{C}$ . Optional six-foot tip cables provide convenient connectivity between a DUT positioned inside a temperature chamber and a Tektronix oscilloscope and isolated current probe located outside the chamber. Available in three attenuation configurations, they deliver exceptional bandwidth performance up to 700 MHz.



## Measuring high-fidelity currents in high power systems

The IsoVu isolated current probes provide the bandwidth you need to accurately see the fast risetimes of wide bandgap (WBG) switching devices. This enables you to accurately measure dynamic currents in high-power SiC and GaN power converters. They complement the groundbreaking IsoVu isolated voltage probes and represent a similar isolation breakthrough for current measurements. The isolation eliminates ground loops and enables accurate measurements of high-side drain currents ( $I_{DS}$ ).

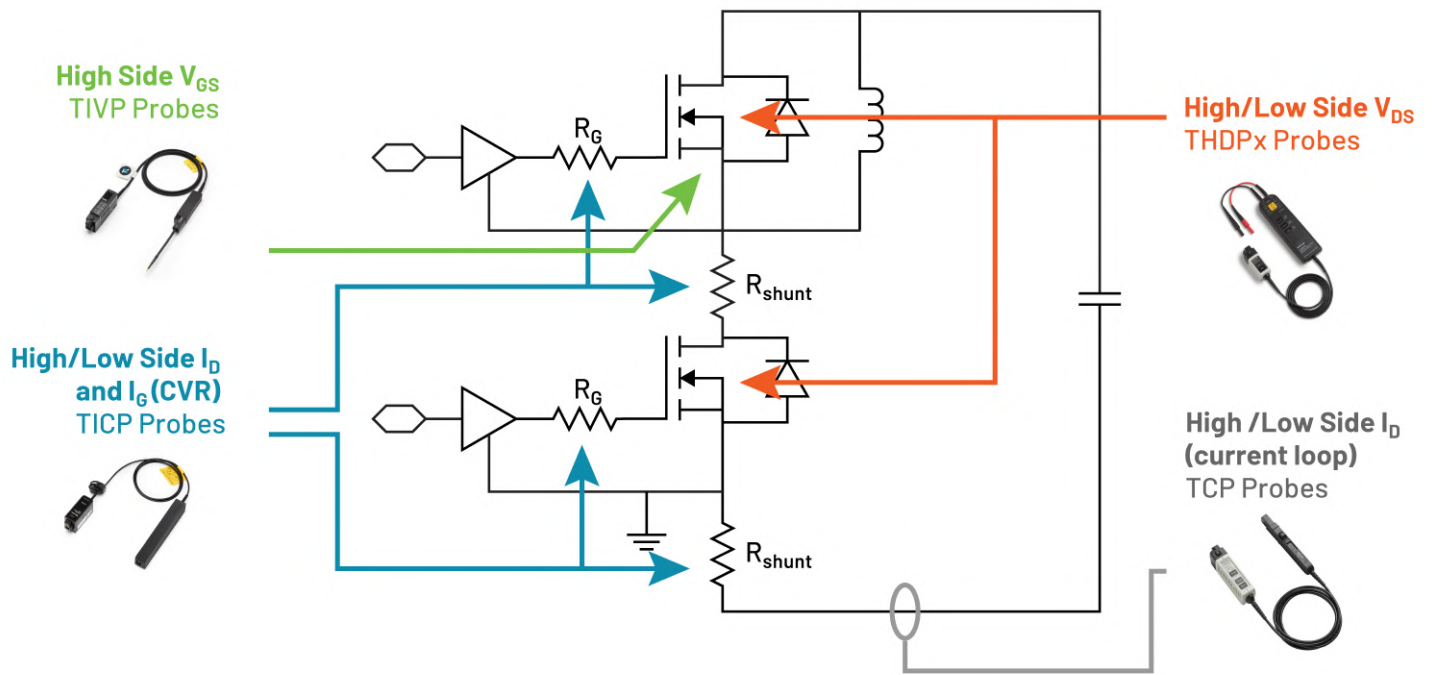

## Measuring low currents in low power systems

The IsoVu isolated current probes have the bandwidth to measure current consumption during specific system activities and transitions from sleep to active states. The low-noise architecture is critical for accurately measuring low currents across the shunts. The common mode voltage rating of these probes is higher than most differential probes, enabling current shunt measurements on higher voltage power rails. When paired with the low-noise of the 6 Series MSO, the overall system offers low-noise performance to efficiently measure rail currents.

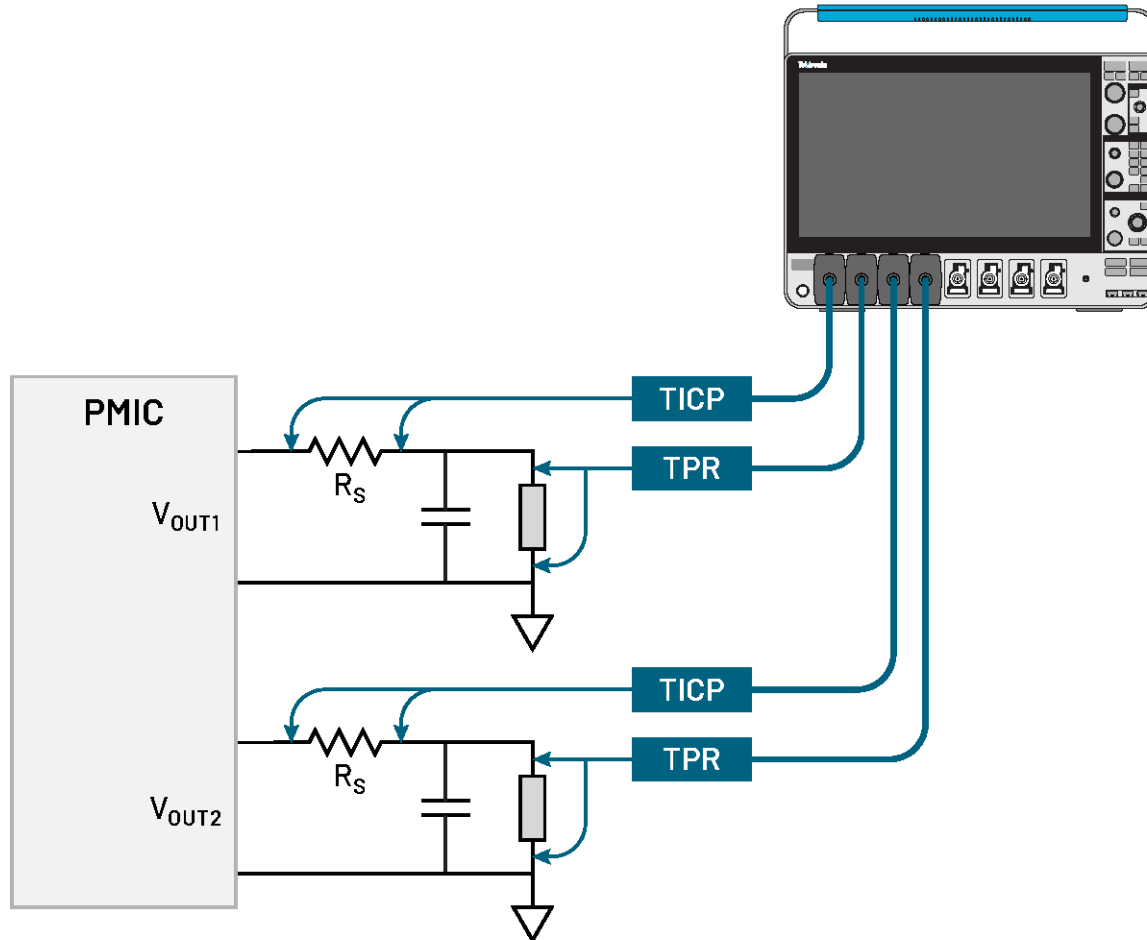

## Specifications

All specifications are typical and apply to all models unless noted otherwise.

### Probe and tip overview

#### IsoVu isolated current probe overview

Characteristic	TICP100	TICP050	TICP025
Bandwidth	1 GHz	500 MHz	250 MHz
Rise time	400 ps	700 ps	1.4 ns
DC gain accuracy	±1.5%		
Maximum common mode voltage	1800 V; For use in a Pollution Degree 1 environment; Max with transient level not to exceed 5kV <sub>pk</sub>		
	1300 V; Pollution degree 2; Max with transient level not to exceed 5kV <sub>pk</sub>		
	600 V for CAT III; Pollution degree 2		
	1000 V for CAT II; Pollution degree 2		
RMS noise spectral density	4.70 nV / √Hz (<21 μV <sub>RMS</sub> at 20 MHz)		
Probe cable length	2 meters		

### Input voltage range, input impedance

Differential input voltage range + offset range should not exceed maximum measurable input voltage. For example, offset is limited to  $\pm 0.15$  V in TICPSMA's  $\pm 0.5$  V range.

Probe tips	Differential input voltage range	Offset range	Maximum measurable input voltage (Vpk)	Maximum non-destructive differential voltage	Input impedance
TICPSMA	$\pm 0.5$ V	$\pm 0.5$ V	0.65 V	$\pm 3$ V; 3 V <sub>RMS</sub>	50 $\Omega$    N.A.
TICPMM1/TICPMM1ET	$\pm 0.5$ V	$\pm 0.5$ V	0.65 V	$\pm 3$ V; 3 V <sub>RMS</sub>	50 $\Omega$    N.A.
TICPMM10/ TICPMM10ET	$\pm 5$ V	$\pm 5$ V	6.5 V	$\pm 15$ V; 15 V <sub>RMS</sub>	500 $\Omega$    <3 pF
TICPMM100/ TICP100MMET	$\pm 50$ V	$\pm 50$ V	50 V	$\pm 60$ V; 60 V <sub>RMS</sub>	5000 $\Omega$    <3 pF

Full  $\pm 0.5$  V offset is available in the IsoVu isolated current probe's  $\pm 0.125$  V range.

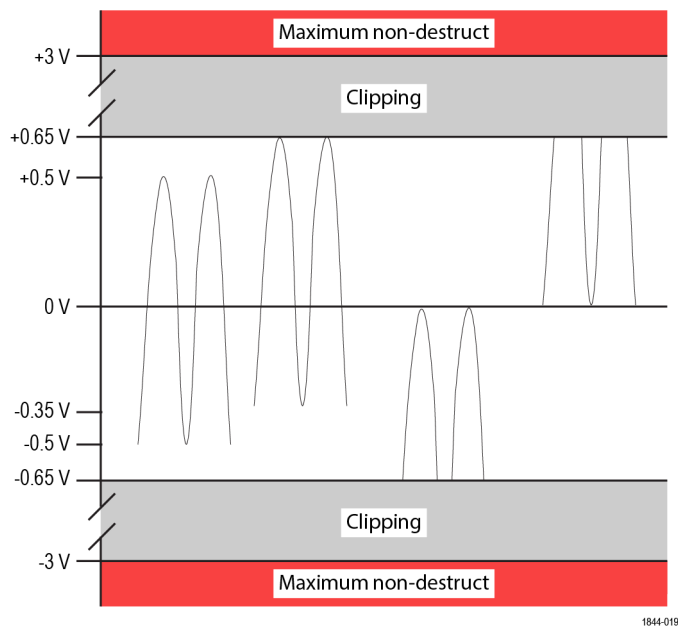

### Differential input voltage range

**Noise floor (A RMS)**

$$\text{Noise Floor (A RMS)} = \frac{4.70 \frac{\text{nV}}{\sqrt{\text{Hz}}} \times \sqrt{\text{Bandwidth}}}{R_{\text{shunt}}}$$

**The IsoVu isolated current probe noise floor (A RMS)**

Shunt selection	20 MHz	250 MHz	1 GHz
50 Ω TICP as shunt	420 nA	1.5 μA	3.0 μA
5 Ω shunt	4.2 μA	14.9 μA	29.7 μA
1 Ω shunt	21 μA	74.3 μA	149 μA
500 mΩ shunt	42 μA	149 μA	297 μA
50 mΩ shunt	420 μA	1.5 mA	3.0 mA
5 mΩ shunt	4.2 mA	14.9 mA	29.7 mA
500 μΩ shunt	42 mA	149 mA	297 mA
50 μΩ shunt	420 mA	1.5 A	3.0 A
15 μΩ shunt	1.4 A	5.0 A	9.9 A

### Maximum measurable current

Maximum depends on shunt power rating.

$$\text{Maximum Measurable Current (A)} = \frac{\text{Maximum Measurable Input } V_{pk}}{R_{shunt}}$$

### The IsoVu isolated current probe maximum measurable current

Shunt selection	TICPMM1	TICPSMA	TICPMM10	TICPMM100
50 Ω TICP as shunt	13 mA		-	-
5 Ω shunt	130 mA		1.3 A	10 A
1 Ω shunt	650 mA		6.5 A	50 A
500 mΩ shunt	1.3 A		13 A	100 A
50 mΩ shunt	13 A		130 A	1.0 kA
5 mΩ shunt	130 A		1.3 kA	10 kA
500 μΩ shunt	1.3 kA		13 kA	100 kA
50 μΩ shunt	13 kA		130 kA	1000 kA
15 μΩ shunt	43.3 kA		433.3 kA	3300 kA

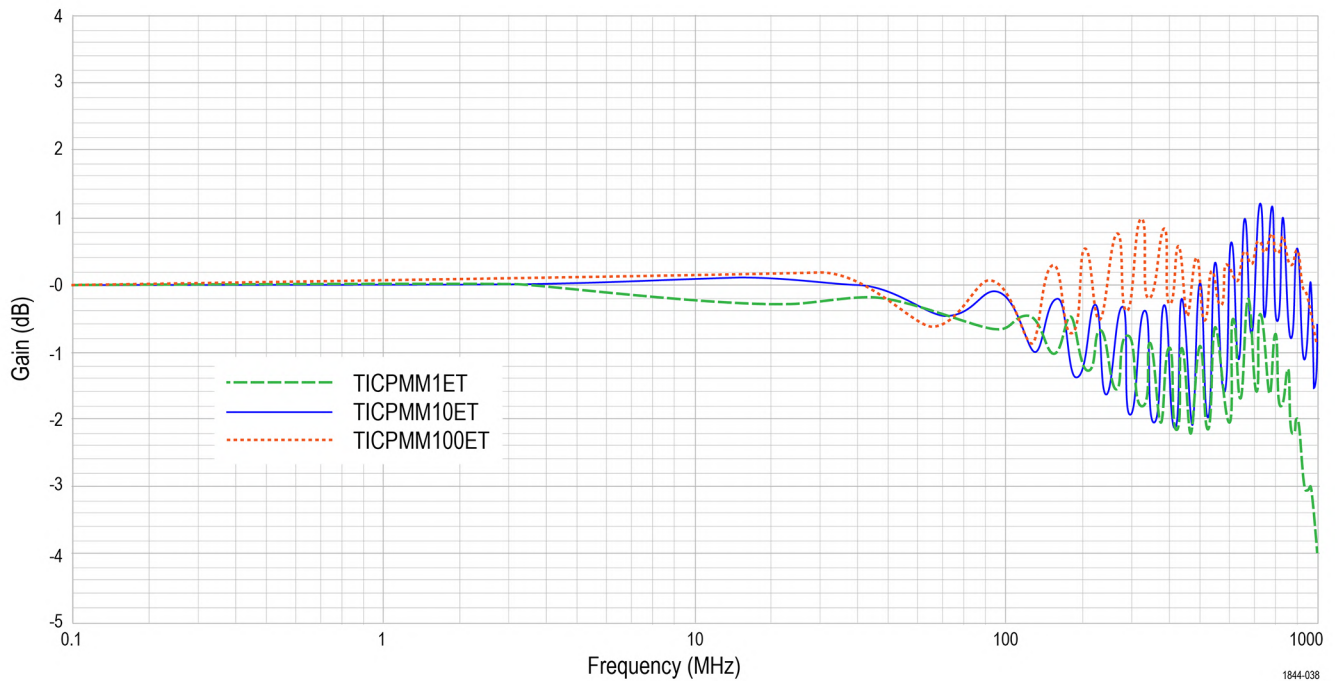

### Extreme temperature tip frequency response

## Probe Ranges

Numbers are published for TICPSMA and TICPMM1 tips. For 10X or 100X tips, multiply by 10 or 100 respectively.

Input range	Offset range	RMS noise spectral density ( $V_{RMS}$ )	Noise floor at 20 MHz ( $V_{RMS}$ )
±0.5 V	±0.15 V	22.9 nV / $\sqrt{Hz}$	102.5 $\mu V_{RMS}$
±0.35 V	±0.30 V	17.4 nV / $\sqrt{Hz}$	77.8 $\mu V_{RMS}$
±0.25 V	±0.40 V	15.0 nV / $\sqrt{Hz}$	67.2 $\mu V_{RMS}$
±0.175 V	±0.475 V	9.5 nV / $\sqrt{Hz}$	42.4 $\mu V_{RMS}$
±0.125 V	±0.5 V	8.7 nV / $\sqrt{Hz}$	38.9 $\mu V_{RMS}$
±0.09 V	±0.5 V	6.3 nV / $\sqrt{Hz}$	28.3 $\mu V_{RMS}$
±0.065 V	±0.5 V	5.5 nV / $\sqrt{Hz}$	24.7 $\mu V_{RMS}$
±0.045 V	±0.5 V	4.7 nV / $\sqrt{Hz}$	21.2 $\mu V_{RMS}$
±0.03 V	±0.5 V	4.7 nV / $\sqrt{Hz}$	21.2 $\mu V_{RMS}$
±0.02 V	±0.5 V	4.7 nV / $\sqrt{Hz}$	21.2 $\mu V_{RMS}$

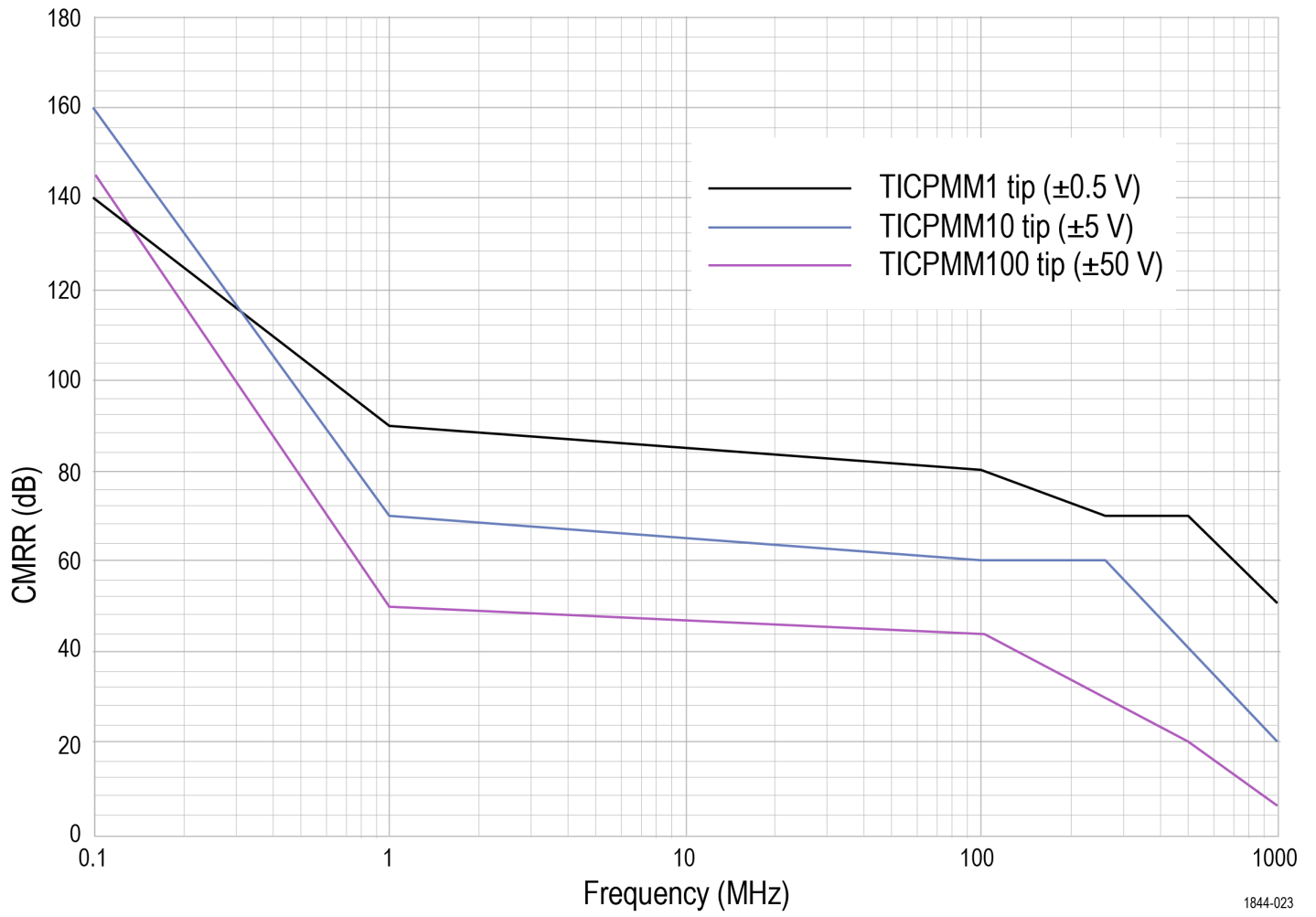

1844-023

*The IsoVu isolated current probes common mode rejection ratio (CMRR)*

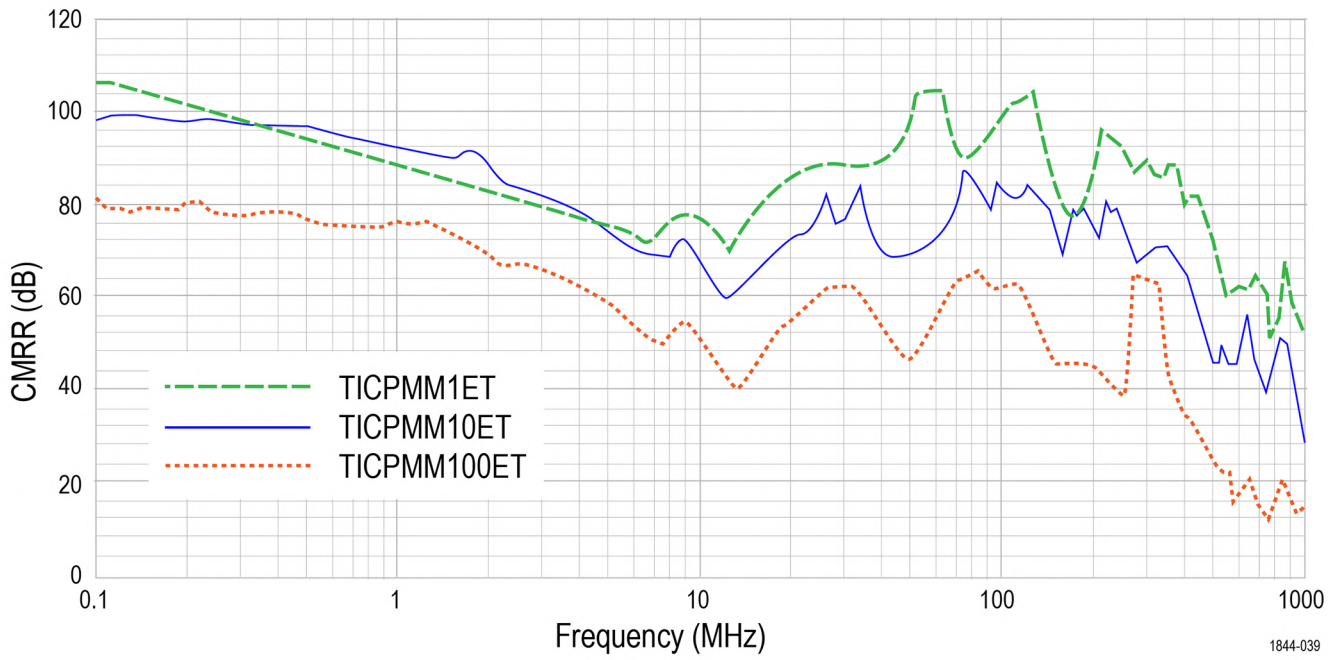

**Extreme temperature CMRR**

## Application Examples

Application examples for Wide Bandgap (WBG) and PMIC power integrity.

### WBG example (800V, 40 A typical; 0.125 $\Omega$ shunt)

In a 800 V SiC circuit switching at 40 A, a 125 m $\Omega$  shunt will produce a 5 V signal. To measure this using the IsoVu isolated current probe the 10X tip must be used. In the  $\pm 3.5$  V range apply 24 A of offset.

The measurable current range goes from 52 A to -4 A. At these settings, the RMS noise floor at 250 MHz bandwidth is 2.2 mA RMS

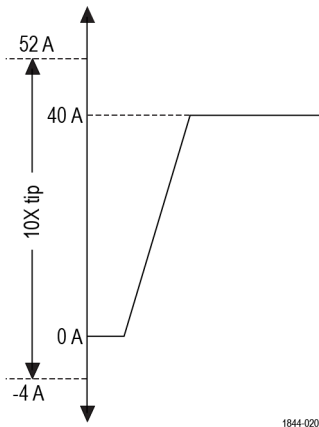

### PMIC power integrity (48 V, 3 mA typical; 1 $\Omega$ shunt)

On a 48 V PMIC bus, the standby current of 3 mA will produce a 3 mV signal on a 1  $\Omega$  shunt. Use the 1X tip in the most sensitive  $\pm 20$  mV range, apply offset to view the 3 mA current and capture transients from 0 A to 40 mA with a RMS noise floor of 21.2  $\mu$ A

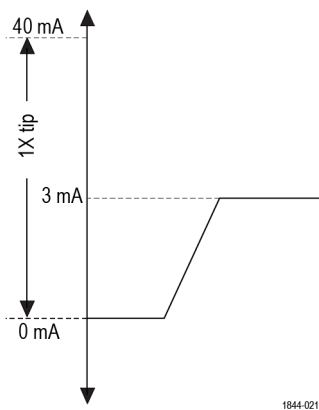

## Environmental requirements

Characteristic	Component	Operating	Non-operating
Compensation box, probe head, and SMA tip adapter temperature		0°C to +50°C	-20°C to +70°C
Standard tips temperature	TICPMM1, TICPMM10, TICPMM100,	-40°C to +85°C	40°C to +85°C
Extreme temperature tips (ET) temperature	TICPMM1ET, TICPMM10ET, TICPMM100ET	-40°C to +125°C	-40°C to +125°C; Storage temperature is -40°C to +85°C
Humidity	All components	5% to 85% relative humidity up to +40°C, 5% to 45% relative humidity up to +50°C, non-condensing	5% to 85% relative humidity up to +40°C, 5% to 45% relative humidity up to +70°C, non-condensing
Altitude	All components	Up to 3,000 meters	Up to 12,000 meters

Tektronix extreme temperature (ET) tips enable accurate current measurements in environmental testing applications across an extended operating range of -40°C to +125°C.

In the illustration below, the shaded region within the dashed boundary indicates the recommended working zone for extreme temperature operation. To prevent environmental chamber access-port leakage from impacting the probe head, this working zone should begin at least 13 inches (330.2 mm) from the probe head.

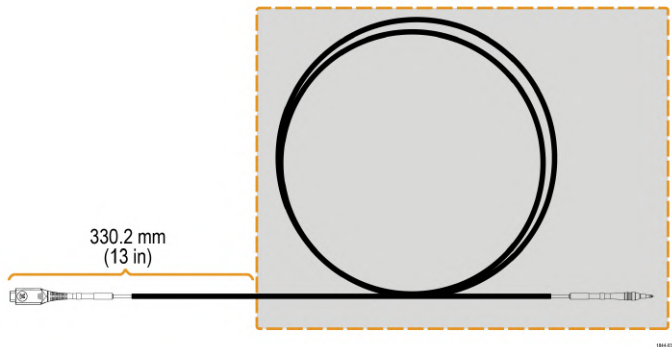

## **Regulatory compliance**

### **EMC**

Conforms to European Union EMC Directive (CE-marked)

### **Safety**

Conforms to European Union Low Voltage Directive (CE-marked)

Conforms to ANSI/UL61010-1 (CSA-marked)

Conforms to ANSI/UL61010-2-030 (CSA-marked)

Certified to CAN/CSA C22.2 No.61010-1 (CSA-marked)

Certified to CAN/CSA C22.2 No.61010-2-030 (CSA-marked)

### **RoHS**

Conforms to European Union Restrictions on Hazardous Substances (CE-marked)

## Ordering information







Select the appropriate instrument and options for your measurement needs.

## Model overview

Model	Description
<a href="#">TICP025</a>	250 MHz Tektronix Isolated Current Probe
<a href="#">TICP050</a>	500 MHz Tektronix Isolated Current Probe
<a href="#">TICP100</a>	1 GHz Tektronix Isolated Current Probe

## Standard accessories







The following table lists the accessories that are shipped with the probe.

Accessory	Description	Part number
	1X probe tip cable with MMCX connector	TICPMM1
	10X probe tip cable with MMCX connector	TICPMM10
	SMA tip adapter	TICPSMA
	Clamp-on ferrite common mode choke	276-0905-XX
	Bipod is used to hold the probe.	020-3210-XX
	Tripod adapter for 1/4 in - 20 UNC thread accessories.	103-0508-XX
	Probe tip adapter. Adapts an MMCX IsoVu tip to standard 0.100" spaced, 0.025" square pins.	131-9717-XX

Accessory	Description	Part number
	Soft carrying case with foam insert.	016-2147-XX

### Recommended accessories

The following table lists optional accessories.

Accessory	Description	Part number
	100X probe tip with MMCX connector	TICPMM100
	1X extreme temperature tip with MMCX connector	TICPMM1ET
	10X extreme temperature tip with MMCX connector	TICPMM10ET
	100X extreme temperature tip with MMCX connector	TICPMM100ET
	Twisted pair solder-in accessory	174-7492-XX
	Square pin to MMCX adapter, 0.062" spacing	131-9677-XX
	MMCX to IC grabber lead	196-3546-XX
	Square pin to IC grabber lead	196-3547-XX
	MicroCKT grabbers	206-0569-XX

## **Supported oscilloscopes**

The measurement systems can be used with the following Tektronix oscilloscopes.

- 4 Series MSO, 4 Series B MSO
- 5 Series MSO, 5 Series B MSO, 5 Series MSO LP
- 6 Series MSO, 6 Series B MSO

## **Service options**

### **Standard warranty**

1 year

### **Opt. R3**

Repair Service 3 Years (including warranty)

### **Opt. R5**

Repair Service 5 Years (including warranty)

### **Opt. C3**

Calibration Service 3 Years

### **Opt. C5**

Calibration Service 5 Years

### **Opt. D1**

Calibration Data Report

### **Opt. D3**

Calibration Data Report 3 Years (with Opt. C3)

### **Opt. D5**

Calibration Data Report 5 Years (with Opt. C5)

### **Opt. T3**

Three year total protection plan, includes repair or replacement coverage from wear and tear, accidental damage, ESD or EOS plus preventative maintenance. Including a 5 day turnaround time and priority access to customer support

### **Opt. T5**

Five year total protection plan, includes repair or replacement coverage from wear and tear, accidental damage, ESD or EOS plus preventative maintenance. Including a 5 day turnaround time and priority access to customer support

Probes and accessories are not covered by the oscilloscope warranty and Service Offerings. Refer to the datasheet of each probe and accessory model for its unique warranty and calibration terms.

Tektronix is registered to ISO 9001:2015 and ISO 14001:2015.

## Contact Information:

**Australia** 1 800 709 465  
**Austria\*** 00800 2255 4835  
**Balkans, Israel, South Africa and other ISE Countries** +41 52 675 3777  
**Belgium\*** 00800 2255 4835  
**Brazil** +55 (11) 3530-8901  
**Canada** 1 800 833 9200  
**Central East Europe / Baltics** +41 52 675 3777  
**Central Europe / Greece** +41 52 675 3777  
**Denmark** +45 80 88 1401  
**Finland** +41 52 675 3777  
**France\*** 00800 2255 4835  
**Germany\*** 00800 2255 4835  
**Hong Kong** 400 820 5835  
**India** 000 800 650 1835  
**Indonesia** 007 803 601 5249  
**Italy** 00800 2255 4835  
**Japan** 81(3) 6714 3086  
**Luxembourg** +41 52 675 3777  
**Malaysia** 1 800 22 55835  
**Mexico, Central/South America and Caribbean** 52 (55) 88 69 35 25  
**Middle East, Asia, and North Africa** +41 52 675 3777  
**The Netherlands\*** 00800 2255 4835  
**New Zealand** 0800 800 238  
**Norway** 800 16098  
**People's Republic of China** 400 820 5835  
**Philippines** 1 800 1601 0077  
**Poland** +41 52 675 3777  
**Portugal** 80 08 12370  
**Republic of Korea** +82 2 565 1455  
**Russia / CIS** +7 (495) 6647564  
**Singapore** 800 6011 473  
**South Africa** +41 52 675 3777  
**Spain\*** 00800 2255 4835  
**Sweden\*** 00800 2255 4835  
**Switzerland\*** 00800 2255 4835  
**Taiwan** 886 (2) 2656 6688  
**Thailand** 1 800 011 931  
**United Kingdom / Ireland\*** 00800 2255 4835  
**USA** 1 800 833 9200  
**Vietnam** 12060128

\* European toll-free number. If not accessible, call: +41 52 675 3777



Mess- und Prüftechnik. Die Experten.

**Ihr Ansprechpartner /  
Your Partner:**

**dataTec AG**

E-Mail: [info@datatec.eu](mailto:info@datatec.eu)

[datatec.eu](http://datatec.eu)

**Tektronix®**

Copyright © Tektronix. All rights reserved. Tektronix products are covered by U.S. and foreign patents, issued and pending. Information in this publication supersedes that in all previously published material. Specification and price change privileges reserved. TEKTRONIX and TEK are registered trademarks of Tektronix, Inc. All other trade names referenced are the service marks, trademarks or registered trademarks of their respective companies.

51W-74063-4 31 Jan 2026