

TECHNICAL
OVERVIEW

Power Splitter

11667L/A/B/C/D: DC to 2/18/26.5/67 GHz

Key Features

- Broad operating frequency up to 67 GHz
- Excellent output VSWR at the auxiliary arm when used for source leveling or ratio measurement applications
- Unmatched tracking between outputs ensures minimum measurement uncertainty

Description

The Keysight Technologies, Inc. 11667x is a 50 ohm two-resistor type power splitter that provides exceptional amplitude and phase tracking for highly accurate power splitting. Offering excellent output power symmetry between the two output ports, the 11667x is recommended for applications that require external source leveling, ratio measurements and for other legacy network/ gain-phase analyzers that do not have built-in power splitters or directional bridges.

Applications

Network measurement

Milliohm impedance measurements with shunt-thru method
(DC-DC converters, large bypass capacitors)

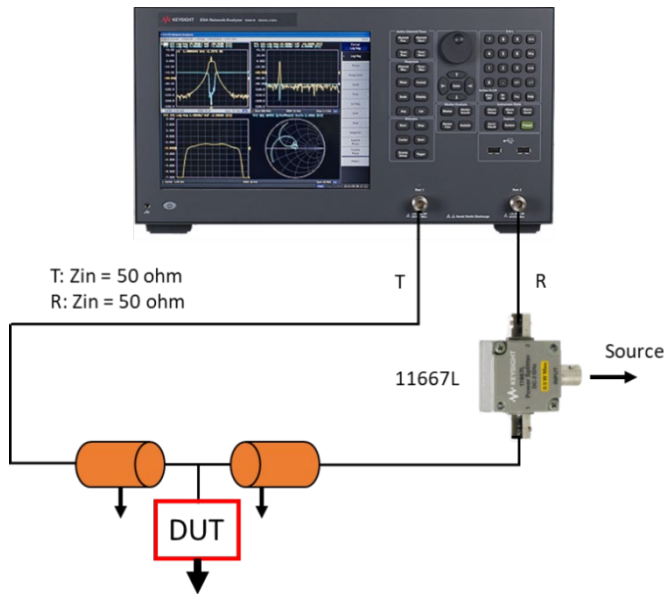

Figure 1. Shunt-thru impedance measurement

Transmission coefficient measurements for 2-port devices

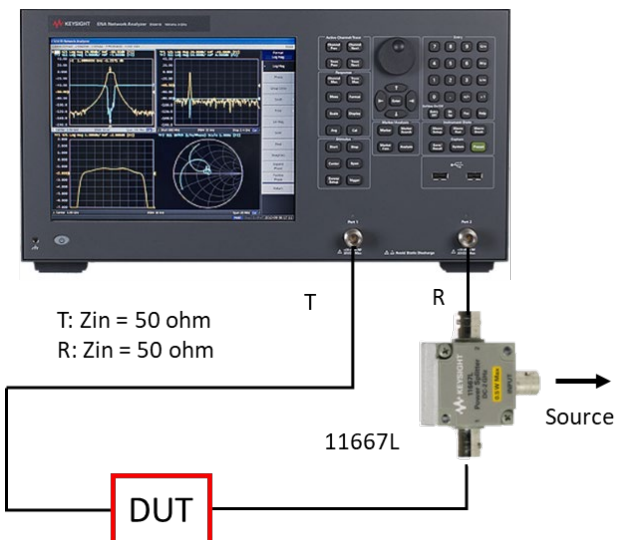

Figure 2. 50-ohm device measurement

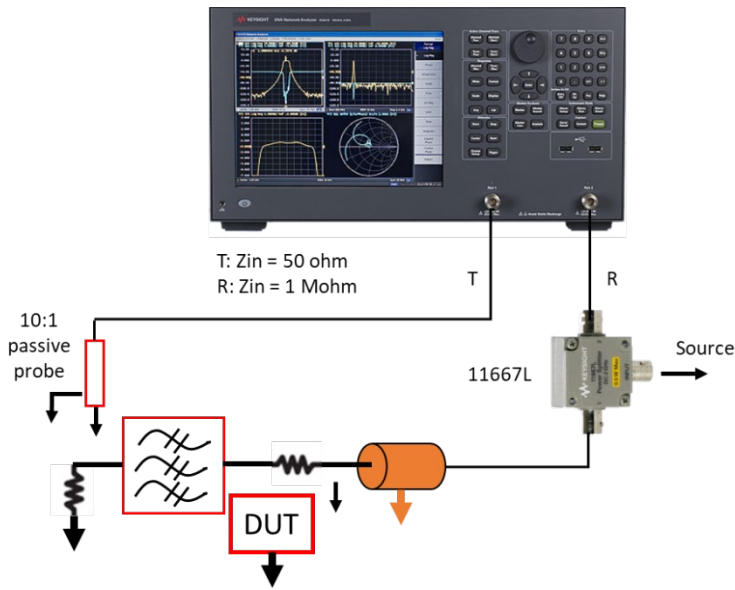

Figure 3. Non- 50-ohm LF filter measurement

Ratioing and Leveling

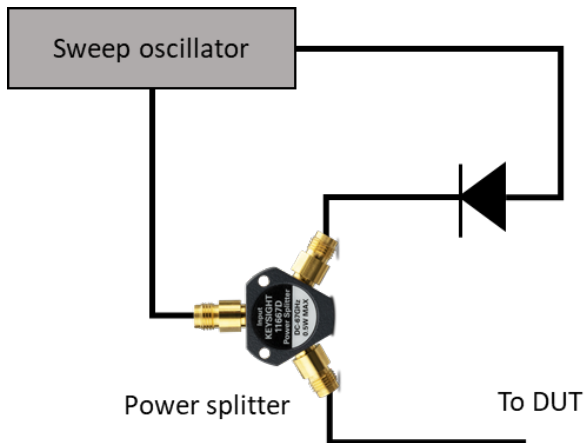

Figure 4. Power splitter test setup for leveling with a crystal detector

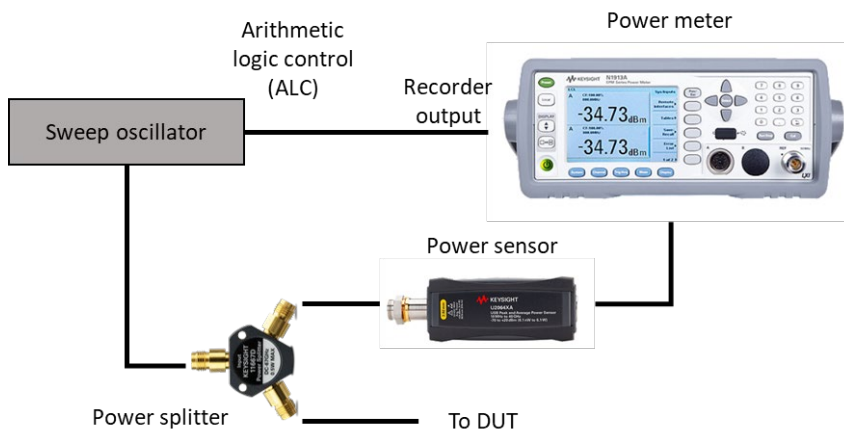

Figure 5. Power splitter test setup for leveling with a power meter

Specifications

Specifications describe the product's warranted performance. Supplemental and typical characteristics are intended to provide typical but non-warranted performance parameters. These are denoted as "typical", "nominal" or "approximate"

Specifications	11667L	11667A	11667B	11667C	11667D
Frequency range	DC to 2 GHz	DC to 18 GHz	DC to 26.5 GHz	DC to 50 GHz	DC to 67 GHz
Connector	BNC (f) all ports	Type-N (f) all ports ¹	3.5 mm (f) all ports	2.4 mm (f) all ports	1.85 mm (f) all ports
Insertion loss (dB)	(6 dB nominal): DC to 100 MHz: 0.2 100 MHz to 2 GHz: 0.6	(6 dB nominal): DC to 4 GHz: 0.2, + 0.6 to any output, typical 4 to 8 GHz: 0.2 + 1.0 to any output, typical 8 to 18 GHz: 0.2 + 1.8 to any output, typical	DC to 26.5 GHz: 7 dB typical	DC to 18 GHz: 6 18 to 26.5 GHz: 7 26.5 to 40 GHz: 8 40 to 50 GHz: 8.5	DC to 18 GHz: 6.5 18 to 26.5 GHz: 7.0 26.5 to 40 GHz: 8.0 40 to 50 GHz: 8.5 50 to 67 GHz: 9.5
Return loss, dB (VSWR)	Input: 18 (1.3) typical Output: 11 (1.78) typical	Input: DC to 4 GHz: 23 (1.15) 4 to 8 GHz: 19 (1.25) 8 to 18 GHz: 15 (1.45) Output: DC to 4 GHz: 26 (1.10) 4 to 8 GHz: 21 (1.20) 8 to 18 GHz: 17 (1.33) (8 to 18 GHz: 17 (1.38) for option 002	Input: DC to 18 GHz: 20 (1.22) 18 to 26.5 GHz: 18 (1.29) Output: DC to 26.5 GHz: 20 (1.22)	Input: DC to 18 GHz: 20 (1.22) 18 to 26.5 GHz: 16 (1.38) 26.5 to 40 GHz: 14 (1.50) 40 to 50 GHz: 12 (1.65) Output: DC to 26.5 GHz: 18 (1.29) 26.5 to 40 GHz: 14 (1.50) 40 to 50 GHz: 12 (1.65)	Input: DC to 18 GHz: 19 (1.25) 18 to 26.5 GHz: 15 (1.43) 26.5 to 40 GHz: 13 (1.58) 40 to 50 GHz: 11 (1.79) 50 to 67 GHz: 9.0 (2.1) Output: DC to 18 GHz: 17 (1.33) 18 to 26.5 GHz: 15 (1.43) 26.5 to 40 GHz: 13 (1.58) 40 to 50 GHz: 11 (1.79) 50 to 67 GHz: 9.0 (2.1)
Amplitude tracking (dB)	DC to 100 MHz: 0.1 100 MHz to 2 GHz: 0.2	DC to 4 GHz: 0.15 4 to 8 GHz: 0.20 8 to 18 GHz: 0.25	DC to 18 GHz: 0.25 18 to 26.5 GHz: 0.40	DC to 18 GHz: 0.30 18 to 26.5 GHz: 0.35 26.5 to 50 GHz: 0.40	DC to 50 GHz: 0.40 50 to 67 GHz: 0.65
Phase tracking (degree) typical	DC to 100 MHz: 1.0 100 MHz to 2 GHz: 3.0	DC to 4 GHz: 0.5 4 to 8 GHz: 1.5 8 to 18 GHz: 3.0	DC to 18 GHz: 1.5 18 to 26.5 GHz: 2.5	DC to 18 GHz: 2.0 18 to 26.5 GHz: 2.5 26.5 to 50 GHz: 3.0	DC to 50 GHz: 4.0 50 to 67 GHz: 7.0
Max input power	+27 dBm	+27 dBm	+27 dBm	+27 dBm	+ 30 dBm

Connectors:

Type-N female on all ports

Option 001: Type-N male on the input and type-N female on the output ports

Option 002: Type-N female on the input and APC-7 on the output ports

Typical Performance

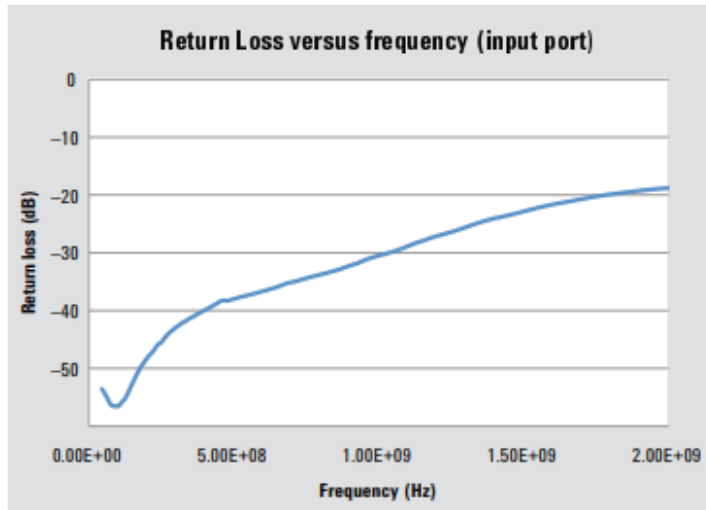

Figure 6. 11667L input port return loss versus frequency (typical)

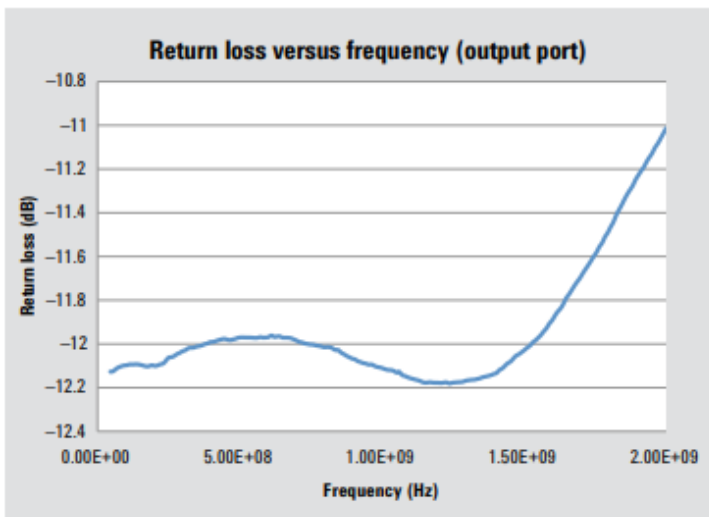

Figure 7. 11667L output port return loss versus frequency (typical)

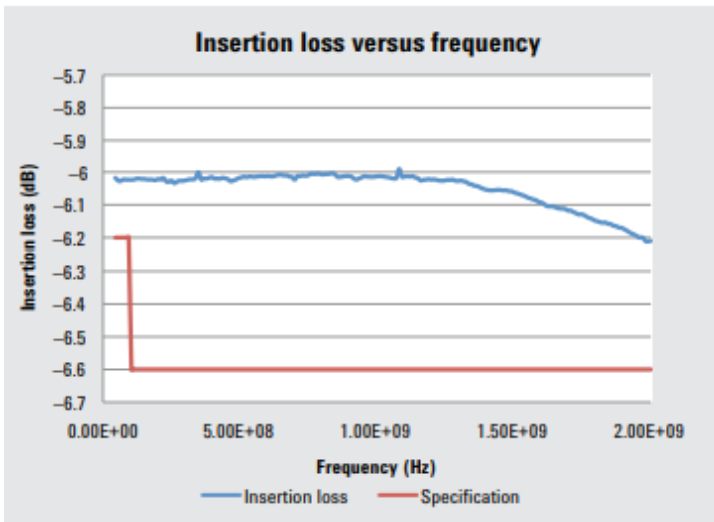

Figure 8. 11667L insertion loss versus frequency (typical)

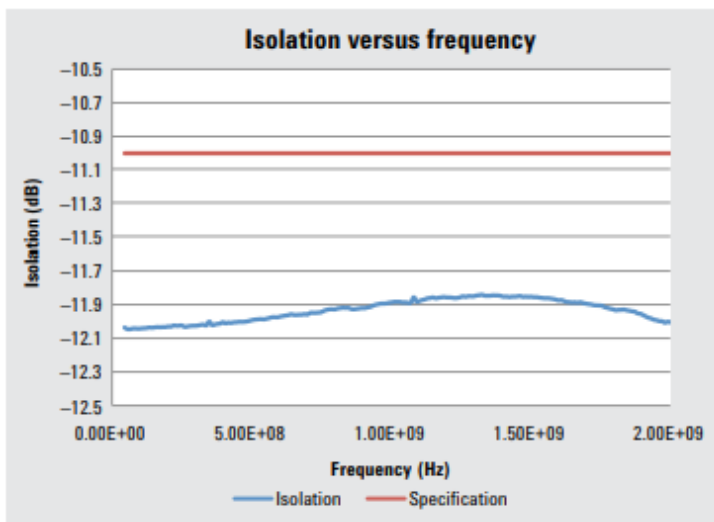

Figure 9. 11667L isolation versus frequency (typical)

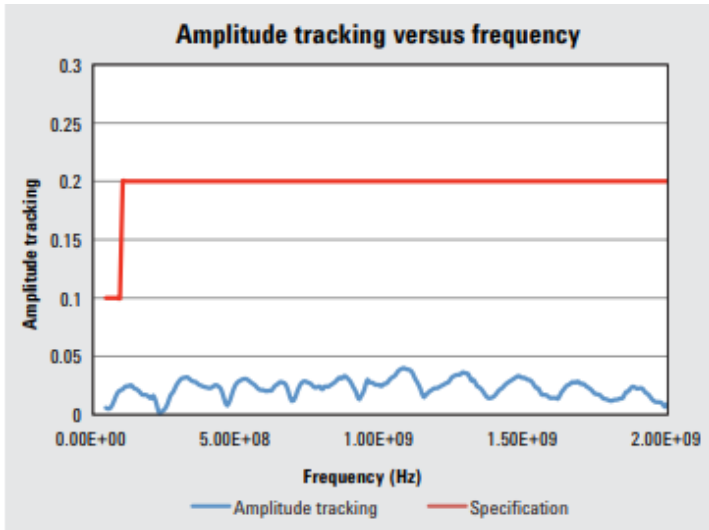

Figure 10. 11667L amplitude tracking (dB) versus frequency (typical)

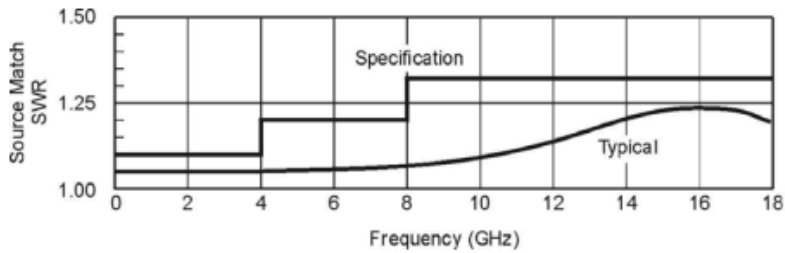

Figure 11. 11667A Leveling or ratio measurement source match (typical)

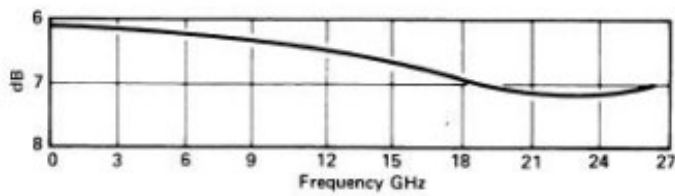

Figure 12. 11667B Insertion loss versus frequency (typical)

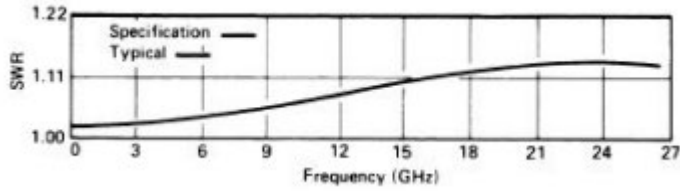

Figure 13. 11667B Leveling or ratio measurement source match (typical)

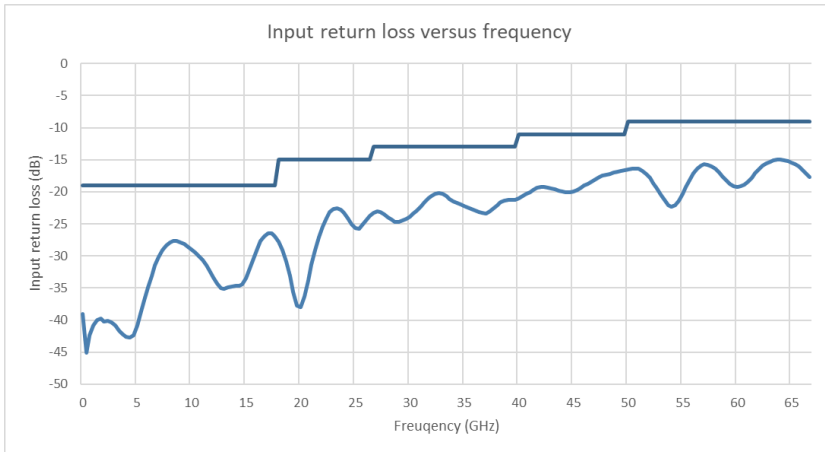

Figure 14. 11667D Input return loss versus frequency (typical)

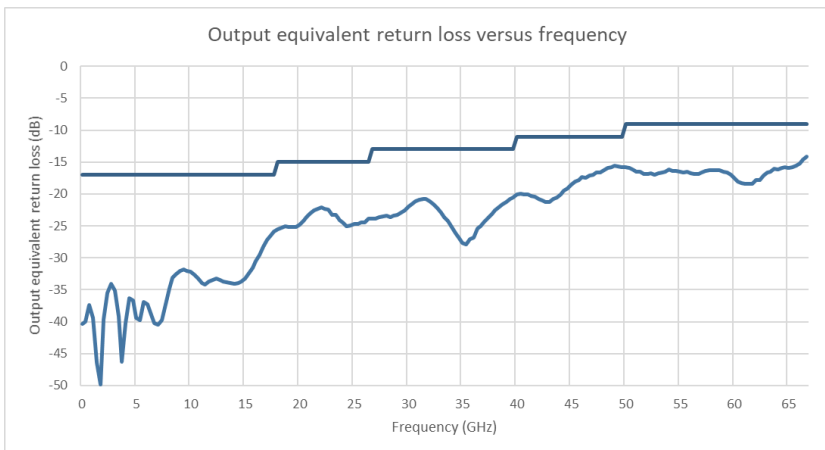

Figure 15. 11667D Output equivalent return loss versus frequency (typical)

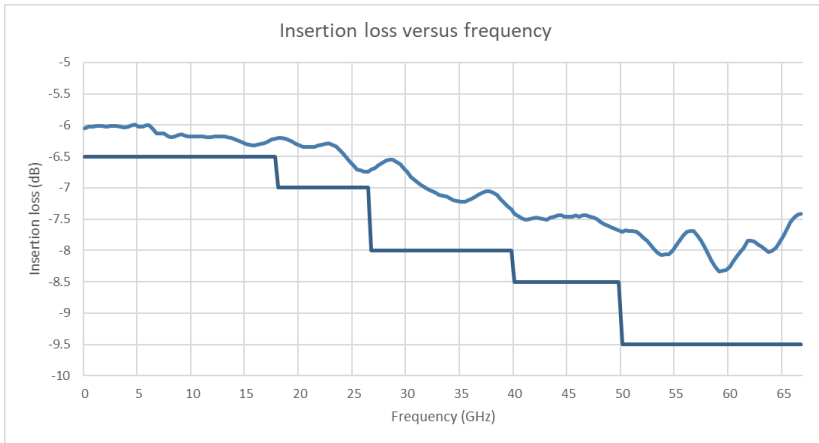

Figure 16. 11667D Insertion loss versus frequency (typical)

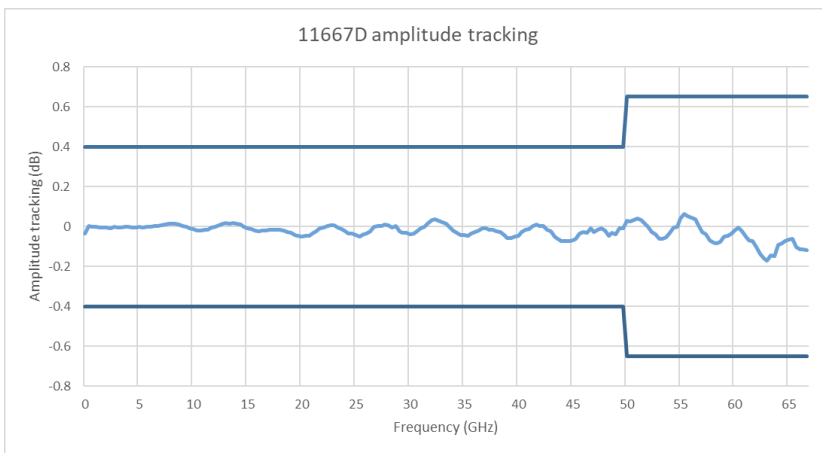

Figure 17. 11667D Amplitude tracking versus frequency (typical)

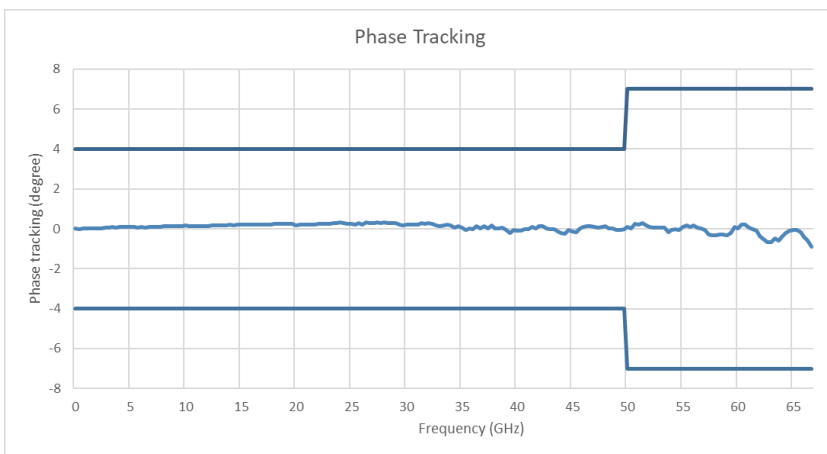

Figure 18. 11667D phase tracking versus frequency (typical)

Environmental Specifications

The 11667x power splitter are designed to fully comply with Keysight Technologies' product operating environment specifications. The following summarizes the environmental specifications for these products.

Environmental condition	11667L
Temperature Operating Non-operating	0 – 55 °C –40 °C to 70 °C
Humidity Non-operating Operating Functional shock	–10 °C to 25 °C / 50% RH 40 °C / 95% RH, 5-day cycle Half-sine, 30 g, 11 ms
Vibration Operating random vibration	5 to 500 Hz, 0.21g RMS
Altitude Operating/storage	≤ 4600 meters (15,000 feet)
ESD immunity Direct discharge Air discharge	6kV 15kV

Environmental condition	11667C
Temperature Operating Non-operating	0°C to +55°C -40°C to +75°C
Humidity Operating/storage	Up to 95% RH
Shock End-user handling Mechanical survival Transportation	Delta-V: 3m/s ±5%, Duration <3ms at 6 faces Half Sine: 1000g, 0.5ms at 6 faces 50g, delta-V: 8m/s at 6 faces
Vibration Operating random	0.3 Grms, 5-500 Hz
Altitude Operating Storage and shipment	Up to 4,572 metres (15,000 feet) Up to 7,620 metres (25,000 feet)
ESD immunity Contac discharge Air discharge	4 kV (to center conductor) 15 kV (to outer conductor)

Environmental condition	11667D
Temperature Operating Storage Cycling	0°C to +55°C -40°C to +75°C -40°C to +75°C, 10 cycles at 20 °C per minute ramp rate, 20 minutes dwell time per MIL-STD-883F, Method 1010.8, Condition C (modified)
Humidity Operating Condensation Resistance	95% RH at 40°C, 24 hours cycling, 5 cycles 95% RH at -10°C to 25°C, Method 2 95% RH at 65°C, 10 Days per JEDEC HAST Standard
Shock End-user handling Mechanical survival Transportation	Delta-V: 3m/s ±5%, Duration <3ms at 6 faces Half Sine: 1000g, 0.5ms at 6 faces 50g, delta-V: 8m/s at 6 faces
Vibration Operating random	0.3 Grms, 5-500 Hz
Altitude Operating Non-operating	4,600 meters (15,092 feet) 4,600 meters (15,092 feet)
ESD immunity Contac discharge Air discharge	4 kV (to center conductor) 15 kV (to outer conductor)

Mechanical Dimensions

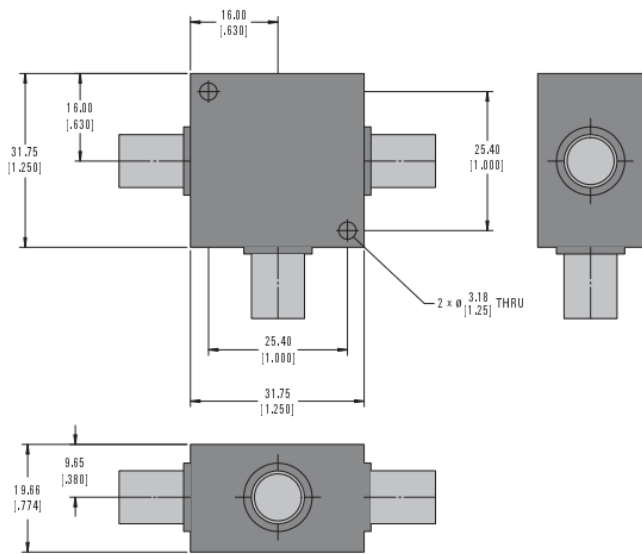

Figure 19. 11667L mechanical dimension

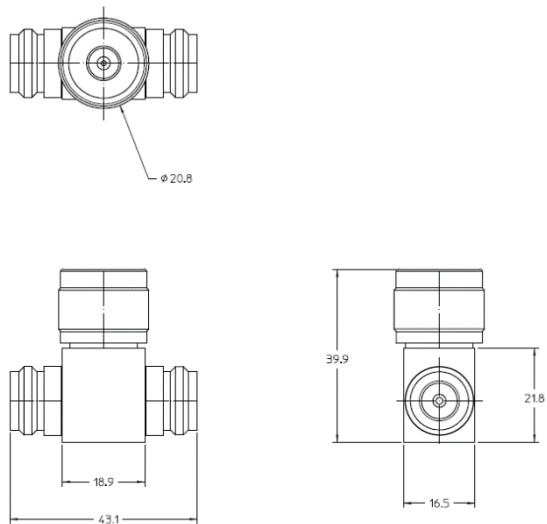

Figure 20. 11667A mechanical dimension

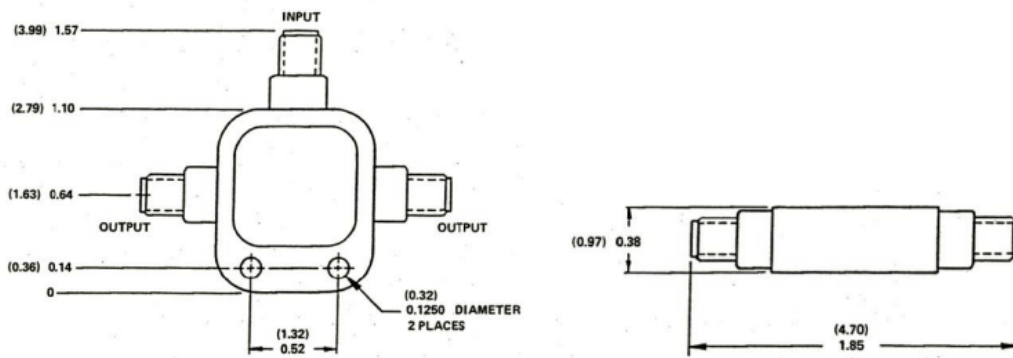

Figure 21. 11667B mechanical dimension

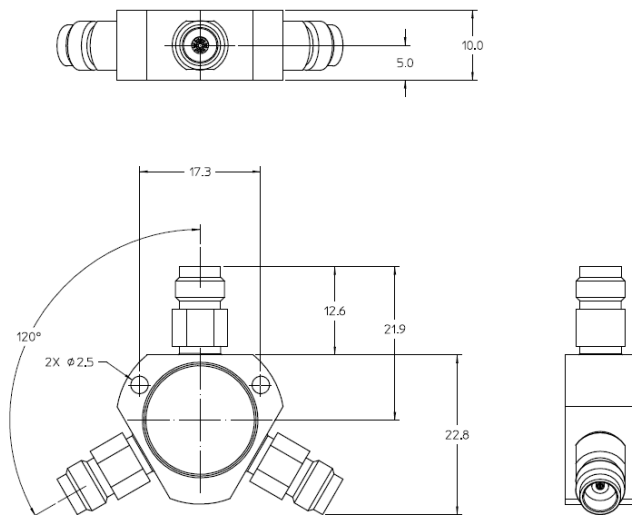

Figure 22. 11667C/D mechanical dimension

Ordering Information

Model	Description
11667L	Power splitter, DC to 2 GHz
11667A	Power splitter, DC to 18 GHz Option 001: Type-N male on the input and type-N female on the output ports Option 002: Type-N female on the input and APC-7 on the output ports
11667B	Power splitter, DC to 26.5 GHz
11667C	Power splitter, DC to 50 GHz
11667D	Power splitter, DC to 67 GHz

Wir haben die Lösungen für Ihre Mess- aufgaben.

dataTec

Mess- und Prüftechnik, Die Experten.

Ihre Vorteile:

- > Diplom-Ingenieure, Elektronik- und Elektrotechniker
- > Langjährige Praxiserfahrung und hohe Kompetenz
- > Bundesweit über 20 praxiserfahrene und herstellerzertifizierte Vertriebsingenieure im Außendienst bei Ihnen vor Ort

Experten für:

- > Oszilloskope
- > Spektrum- / Netzwerkanalysatoren
- > Netzgeräte / Stromversorgungen
- > Thermografie / Temperatur
- > Prüfgeräte VDE / Netzanalyse
- > u. v. m.

